

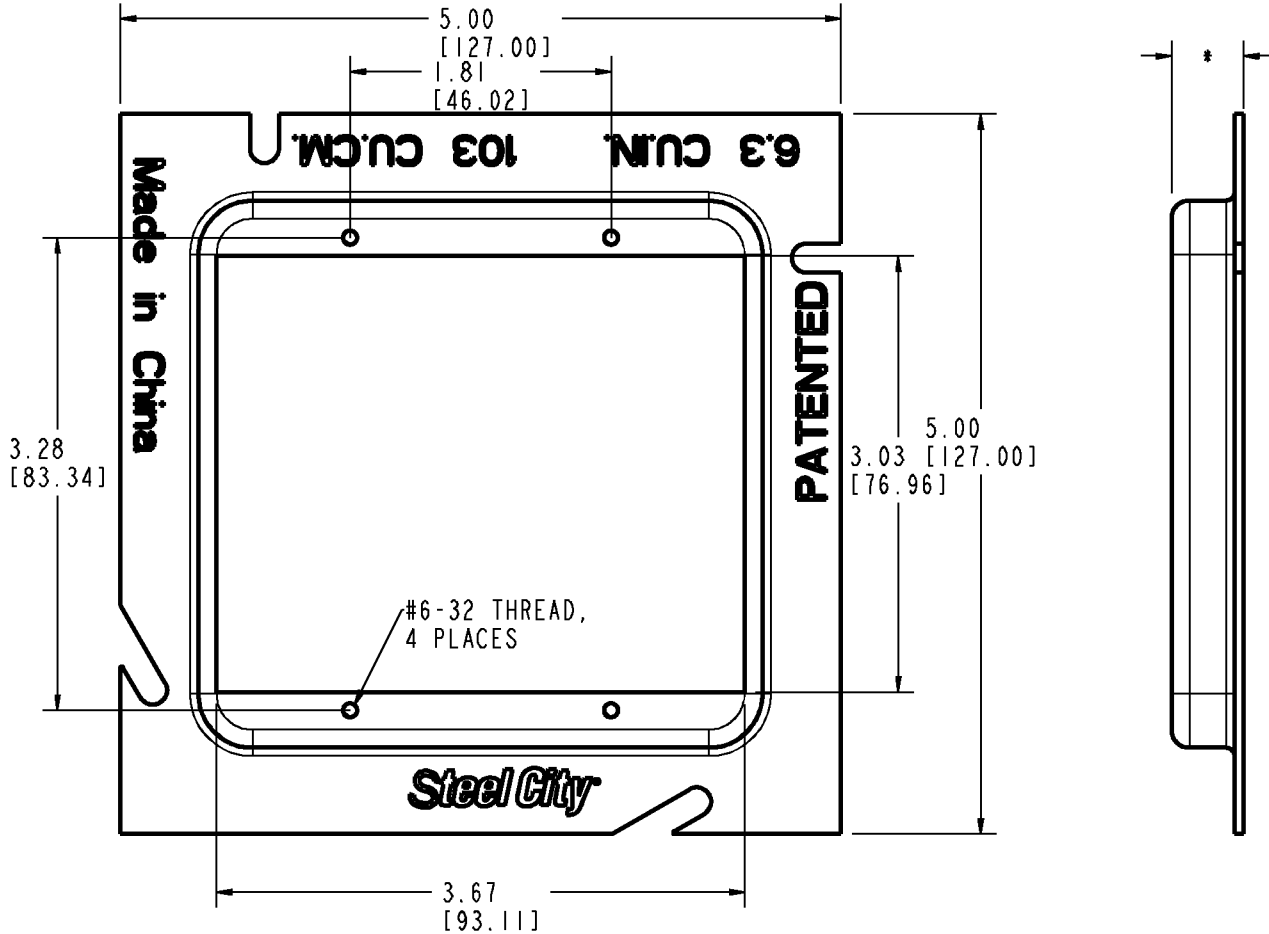

# Steel City



**NOTES:**

1. CAT. NO. 82C-2G-1/2.
2. METAL MINIMUM THICKNESS .063".
3. ZINC PLATED.

*	VOLUME		CATALOG NO
FLAT	—		82C-2G-0
1/4	3	IN <sup>3</sup> [49 CM <sup>3</sup> ]	82C-2G-1/4
1/2	6.3	IN <sup>3</sup> [103 CM <sup>3</sup> ]	82C-2G-1/2
5/8	7.8	IN <sup>3</sup> [128 CM <sup>3</sup> ]	82C-2G-5/8
3/4	9.5	IN <sup>3</sup> [159 CM <sup>3</sup> ]	82C-2G-3/4
1	12.8	IN <sup>3</sup> [210 CM <sup>3</sup> ]	82C-2G-1
1-1/4	17	IN <sup>3</sup> [279 CM <sup>3</sup> ]	82C-2G-1-1/4
1-1/2	20	IN <sup>3</sup> [328 CM <sup>3</sup> ]	82C-2G-1-1/2
2	26	IN <sup>3</sup> [427 CM <sup>3</sup> ]	82C-2G-2

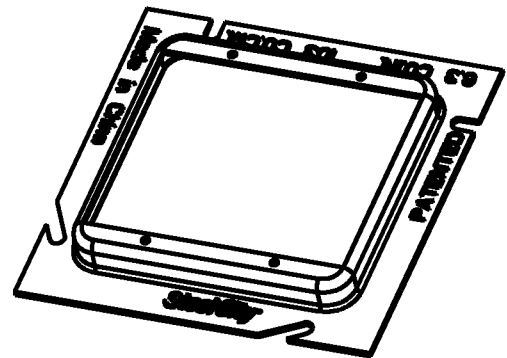

**GENERAL NOTES**

1. ALL DIMENSIONS ARE FOR REFERENCE ONLY.
2. DIMENSIONS IN BRACKETS [ ] ARE IN METRIC UNITS.

www.tnb.com

**Thomas & Betts**

A Member of the ABB Group

**REVISIONS**

SEE ERN (\*\*\*\*) FOR APPROVAL SIGNATURES & RELEASE DATE.  
PROJECT NO: \*\*\*\*

DESCRIPTION:

**5" SQUARE RAISED  
DOUBLE GANG EXTENSION RING**

ORIGINAL PROJECT NO / ( ERN NO )

001P000414/(2014664)

SHEET NO:

1 OF 1

REV. NO:

-

DRAWING NO:

**WSD-001191**