



Kit includes 2 H101 Bullet floodlights pre-assembled on a CU4 universal mounting plate.

Color: Black

Weight: 3.5 lbs

**Project:**

**Type:**

**Prepared By:**

**Date:**

**Lamp Info**

Type PAR38  
 Watts 300W  
 Shape/Size N/A  
 Base N/A  
 ANSI N/A  
 Hours N/A  
 Lamp Lumens N/A  
 Efficacy N/A

**Ballast Info**

Type N/A  
 120V N/A  
 208V N/A  
 240V N/A  
 277V N/A  
 Input Watts N/A

## Technical Specifications

### Compliance

**UL Listed:**

Suitable for wet locations. Suitable for mounting within 1.2m (4ft) of the ground. Can be aimed above horizontal with accessory hood or visor.

### Electrical

**Sockets:**

Porcelain with all copper current carrying components

### Other

**Compatibility with old H100:**

H101 floods and accessories replace the discontinued RAB H100 and accessories. Parts are not interchangeable. Contact factory for price and availability of the old H100 Series.

### Buy American Act Compliance:

RAB values USA manufacturing! Upon request, RAB may be able to manufacture this product to be compliant with the Buy American Act (BAA). Please contact customer service to request a quote for the product to be made BAA compliant.

### Construction

**Swivels:**

Fully adjustable with sure-grip locks. 1/2" NPS threaded arm with serrated locking swivel fits all standard mounting covers. Color matched EZ Grip lock nuts.

**Housings:**

Die-cast aluminum with powder coat finish

### Gaskets:

High-temperature silicone rubber extends around both socket and lamp

### Optical

**Lamps:**

Medium base Par-38 lamps up to 150 watts. Halogen lamps give brighter light and choice of beam spreads.

## Dimensions

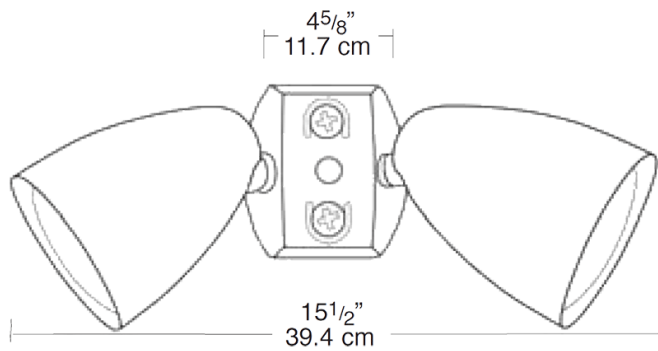

## Features

- Lamp recessed 1" from lip for side glare reduction
- Set screw for hood, grill or visor attachment
- Heavy duty mounting arm with internal O-ring, locking teeth, and stainless steel screw
- Large Silicone rubber gasket provides weatherproof protection around the lamp and socket
- HV1 Visor with integral guard and glass lens for maximum glare reduction and lamp protection
- HG1 Guard: Protects lamp from damage and vandalism
- HH1 Hood with glass lens reduces glare and protects lamp from water and impact damage