

Foot element - UMK-FE - 2970031

Please be informed that the data shown in this PDF Document is generated from our Online Catalog. Please find the complete data in the user's documentation. Our General Terms of Use for Downloads are valid (<http://phoenixcontact.com/download>)

Foot element, for mounting on DIN rail NS 32 or DIN rail NS 35/7.5, can be inserted between base and side element



Your advantages

- ✓ The modules can be marked using the marking grooves in the lateral element as well as with the Phoenix Contact PMB module marker, which is snapped into a bore hole (4 mm Ø) in the PCB
- ✓ Fast assembly thanks to the plug-in module principle. The tight engagement of the individual elements ensures that they are securely connected.
- ✓ Wide range of options for external conductor connection
- ✓ Due to the universal foot, the modules can be snapped onto standard EN DIN rails
- ✓ The mounting flange supports direct wall mounting

Key Commercial Data

Packing unit	10 pc
Minimum order quantity	10 pc
GTIN	 4 017918 087562
GTIN	4017918087562

Technical data

Product properties

Brief article description	Foot element
Type	UMK-FE
Order No.	2970031
Housing type	Press-drawn section housings

Dimensions

Material specifications

Housing material	Polyamide
------------------	-----------

Packaging specifications

Foot element - UMK-FE - 2970031

Technical data

Packaging specifications

Pieces per package	10
Denomination packing units	Pcs.

Environmental Product Compliance

China RoHS	Environmentally friendly use period: unlimited = EFUP-e
	No hazardous substances above threshold values

Drawings

Dimensional drawing

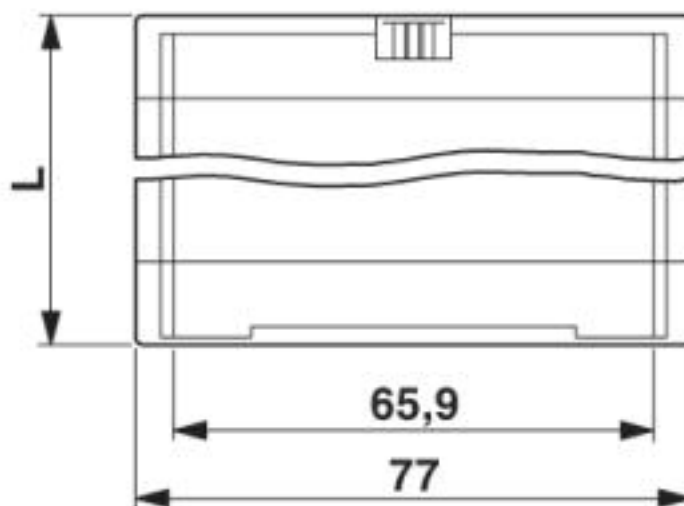
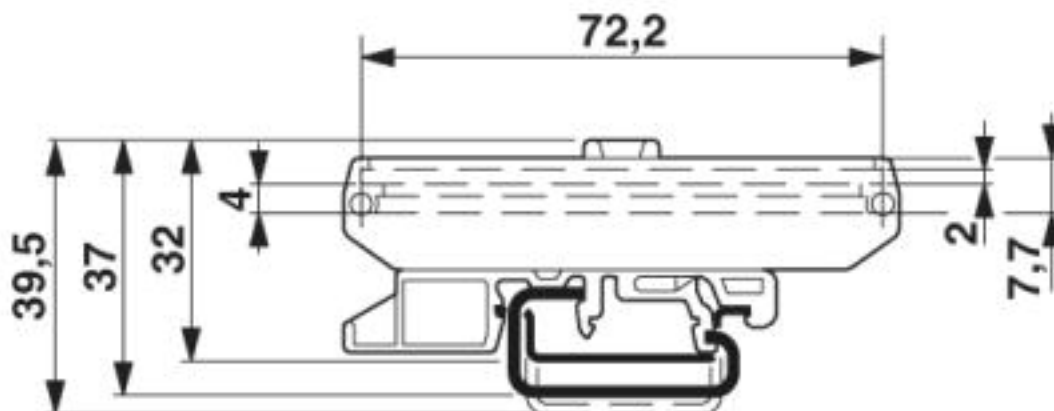

Classifications

eCl@ss

eCl@ss 4.0	27180400
------------	----------

Foot element - UMK-FE - 2970031

Classifications

eCl@ss

eCl@ss 4.1	27180400
eCl@ss 5.0	27180500
eCl@ss 5.1	27180500
eCl@ss 6.0	27180800
eCl@ss 7.0	27182701
eCl@ss 8.0	27182701
eCl@ss 9.0	27182701

ETIM

ETIM 2.0	EC001031
ETIM 3.0	EC001031
ETIM 4.0	EC001031
ETIM 5.0	EC002779
ETIM 6.0	EC002779
ETIM 7.0	EC002779

UNSPSC

UNSPSC 6.01	31261501
UNSPSC 7.0901	31261501
UNSPSC 11	31261501
UNSPSC 12.01	31261501
UNSPSC 13.2	31261501
UNSPSC 18.0	31261501
UNSPSC 19.0	31261501
UNSPSC 20.0	31261501
UNSPSC 21.0	31261501

Approvals

Approvals

Approvals

UL Recognized / EAC

Ex Approvals

Approval details

Foot element - UMK-FE - 2970031

Approvals

UL Recognized		http://database.ul.com/cgi-bin/XYV/template/LISEXT/1FRAME/index.htm	FILE E 240868
---------------	---	---	---------------

EAC			B.01742
-----	---	--	---------

Phoenix Contact 2020 © - all rights reserved
<http://www.phoenixcontact.com>

PHOENIX CONTACT GmbH & Co. KG
Flachmarktstr. 8
32825 Blomberg
Germany
Tel. +49 5235 300
Fax +49 5235 3 41200
<http://www.phoenixcontact.com>