

Resistance/potiposition transducer - MINI MCR-SL-R-UI - 2864095

Please be informed that the data shown in this PDF Document is generated from our Online Catalog. Please find the complete data in the user's documentation. Our General Terms of Use for Downloads are valid (<http://phoenixcontact.com/download>)



MCR potiposition transducer for conversion of potentiometer positions into a standard analog signal, 0 Ω input... 100 Ω to 0 kΩ ... 100 kΩ

Product description

The slim MINI MCR-SL-R-UI... potiposition transducer has a width of only 6.2 mm and converts potentiometer positions as a percentage to an analog standard signal. If the potentiometer range cannot be utilized to the full, an externally accessible slide switch is used to set the upper and lower potiposition end values. The output signal between 0 and 100% is based on this fixed end value.

The DIP switches are accessible on the side of the housing and allow the following parameters to be configured:

- Output signal,
- Automatic potentiometer detection,
- Open circuit detection slider and
- Fault evaluation type.

Power (19.2 V DC to 30 V DC) can be supplied through connection terminals on the modules or in conjunction with the DIN rail connector.

Why buy this product

- ✓ Power supply possible via the foot element (TBUS)
- ✓ Automatic potentiometer detection without manual adjustment
- ✓ Error indication via diagnostic LED and analog signal
- ✓ For 100 Ω to 100 kΩ potentiometers
- ✓ potentiometer signals to create standard signals
- ✓ Configurable measuring range and output signals
- ✓ Highly-compact potentiometer transducer for electrical isolation, conversion, amplification, and filtering of
- ✓ Input and output signals can be configured via DIP switches
- ✓ 3-way isolation
- ✓ A potentiometer sub-range can be linearized via the "teach-in" switch on the device



Key commercial data

Packing unit	1 pc
GTIN	 4 046356 046442
Weight per Piece (excluding packing)	73.17 g
Custom tariff number	85437090
Country of origin	Germany

Resistance/potipotition transducer - MINI MCR-SL-R-UI - 2864095

Technical data

Note

Utilization restriction	EMC: class A product, see manufacturer's declaration in the download area
-------------------------	---

Dimensions

Width	6.2 mm
Height	93.1 mm
Depth	102.5 mm

Ambient conditions

Ambient temperature (operation)	-20 °C ... 65 °C
Ambient temperature (storage/transport)	-40 °C ... 85 °C

Input data

Potentiometer	100 Ω ... 100 kΩ
Reference voltage source	< 3.6 V

Output data

Voltage output signal	0 V ... 5 V
	0 V ... 10 V
	1 V ... 5 V
	10 V ... 0 V
Current output signal	0 mA ... 20 mA
	4 mA ... 20 mA
	20 mA ... 0 mA
	20 mA ... 4 mA
Max. voltage output signal	12.5 V
Max. current output signal	23 mA
Load/output load voltage output	> 10 kΩ
Load/output load current output	< 500 Ω (20 mA)

Power supply

Supply voltage	24 V DC
	19.2 V DC ... 30 V DC (The DIN rail bus connector (ME 6,2 TBUS-2 1,5/5-ST-3,81 GN, Order No. 2869728) can be used to bridge the supply voltage. It can be snapped onto a 35 mm DIN rail according to EN 60715))
Current consumption	< 25 mA (at 24 V DC)

Connection data

Conductor cross section solid min.	0.2 mm ²
Conductor cross section solid max.	2.5 mm ²
Conductor cross section AWG/kcmil min.	26
Conductor cross section AWG/kcmil max.	12
Conductor cross section stranded min.	0.2 mm ²
Conductor cross section stranded max.	2.5 mm ²

Resistance/potiposition transducer - MINI MCR-SL-R-UI - 2864095

Technical data

Connection data

Stripping length	12 mm
Screw thread	M3
Connection method	Screw connection

General

Maximum transmission error	< 0.2 %
Maximum temperature coefficient	< 0.02 %/K
Ambient temperature (operation)	-20 °C ... 65 °C
Ambient temperature (storage/transport)	-40 °C ... 85 °C
Housing material	PBT
Color	green
Conformance	CE-compliant
ATEX	# II 3 G Ex nA IIC T4 Gc X
UL, USA / Canada	UL 508 Recognized
GL	GL EMC 2 D

EMC data

Designation	Electromagnetic RF field
Standards/regulations	EN 61000-4-3
Typical deviation from the measuring range final value	5 %
Designation	Fast transients (burst)
Standards/regulations	EN 61000-4-4
Typical deviation from the measuring range final value	5 %
Designation	Conducted interferences
Standards/regulations	EN 61000-4-6
Typical deviation from the measuring range final value	5 %

Classifications

eCl@ss

eCl@ss 4.0	27210120
eCl@ss 4.1	27210120
eCl@ss 5.0	27210120
eCl@ss 5.1	27210120
eCl@ss 6.0	27210120
eCl@ss 7.0	27210107
eCl@ss 8.0	27210107

ETIM

ETIM 2.0	EC001485
ETIM 3.0	EC001485
ETIM 4.0	EC001485

Resistance/potiposition transducer - MINI MCR-SL-R-UI - 2864095

Classifications

ETIM

ETIM 5.0	EC001485
----------	----------

UNSPSC

UNSPSC 6.01	30211506
UNSPSC 7.0901	39121008
UNSPSC 11	39121008
UNSPSC 12.01	39121008
UNSPSC 13.2	39121008

Approvals

Approvals

Approvals

UL Recognized / cUL Recognized / GL / cULus Recognized

Ex Approvals

Approvals submitted

Approval details

UL Recognized

cUL Recognized

GL

cULus Recognized

Accessories

Accessories

DIN rail connector

Resistance/potiposition transducer - MINI MCR-SL-R-UI - 2864095

Accessories

DIN rail connector - ME 6,2 TBUS-2 1,5/5-ST-3,81 GN - 2869728



DIN rail connector for DIN rail mounting. Universal for TBUS housing. Gold-plated contacts, 5-pos.

Marking material

Transparent cover - MINI MCR DKL - 2308111



Fold up transparent cover for MINI MCR modules with additional labeling option using insert strips and flat Zack marker strip 6.2 mm

Marking label - MINI MCR-DKL-LABEL - 2810272



Label for extended marking of MINI MCR modules in connection with the MINI MCR-DKL

Power module

Power terminal block - MINI MCR-SL-PTB - 2864134



MCR power terminal block for supplying several MINI Analog modules via the DIN rail connector, with screw connection, maximum current consumption of up to 2 A

Power terminal block - MINI MCR-SL-PTB-SP - 2864147



MCR power terminal block for supplying several MINI Analog modules via the DIN rail connector, with spring-cage connection, maximum current consumption of up to 2 A

Power supply

Resistance/potiposition transducer - MINI MCR-SL-R-UI - 2864095

Accessories

Power supply unit - MINI-SYS-PS-100-240AC/24DC/1.5 - 2866983



Primary-switched MINI POWER supply for DIN rail mounting, input: 1-phase, output: 24 V DC/1.5 A

Power supply unit - MINI-PS-100-240AC/24DC/1.5/EX - 2866653



Primary-switched power supply MINI POWER for DIN rail mounting, input: 1-phase, output: 24 V DC/1,5 A, for the potentially explosive area

System adapter

System adapter - MINI MCR-SL-V8-FLK 16-A - 2811268



Eight MINI analog signal converters with screw connection method can be connected to a control system using a system adapter and system cabling with a minimum of wiring and very low error risk.

Drawings

Application drawing

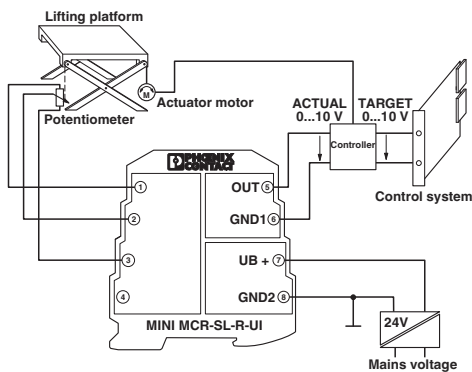

Block diagram

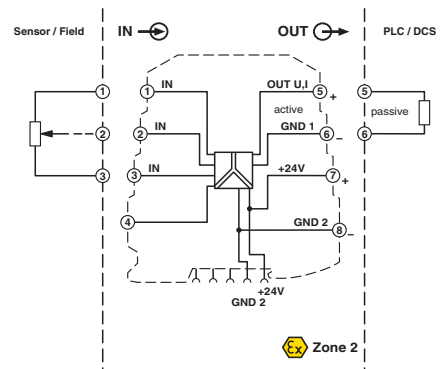

Height adjustment of a lifting platform with setpoint and actual value control

Resistance/potiposition transducer - MINI MCR-SL-R-UI - 2864095

Dimensioned drawing

