

Specification Submittal Data / Panasonic Ventilation Fan

Description:

Supply Air Fan fan shall be Low Noise wall mount type rated for continuous run. Fan shall be ENERGY STAR® rated and certified by the Home Ventilating Institute (HVI). Evaluated by Underwriters Laboratories and conform to both UL and cUL safety standards.

Motor/Blower:

- Four-pole totally enclosed condenser motor rated for continuous run.
- Power rating shall be 120 volts and 60 Hz.
- Motor equipped with thermal-cutoff fuse.
- Merv 8 filter.

Housing:

- Galvanized steel wall sleeve.
- Includes interior deflector grille, interstitial wall sleeve and exterior hood.
- This product fits in a 4.5 inch - 6 inch thick wall and can extend to 10" with additional ducting.

Grille:

- Main unit and exterior hood attach directly to fan housing.
- Interior deflector grille is ABS plastic; exterior hood is Poly Pro UV resistant.
- Interior grille deflector pushes air up and to the side of interior wall.
- Exterior hood includes a bird screen.

Warranty:

- ALL Parts: For period of 3 years from the date of the original purchase

Architectural Specifications:

Supply Air Fan shall be of the through-the-wall mount, ENERGY STAR® rated type, with no less than 10 CFM, including an on/off switch, and no more than <0.3 sone at .03" w.g. static pressure, as certified by the Home Ventilating Institute (HVI). Fan includes a 10 CFM/on/off switch on side of main unit. Power consumption shall be no greater than 3 watts and ENERGY STAR® rated with efficiency rating of no less than 4.7 CFM/watt. The motor shall be totally enclosed, four pole condenser type engineered to run continuously. Power rating shall be 120v/60Hz. Duct diameter shall be no less than 4". Fan shall include an interior deflector grille, interstitial wall sleeve and exterior hood. Fan may be used to comply with ASHRAE 62.2, LEED, ENERGY STAR® IAP, EarthCraft, CalGreen, California Title-24, and WA Ventilation Codes.

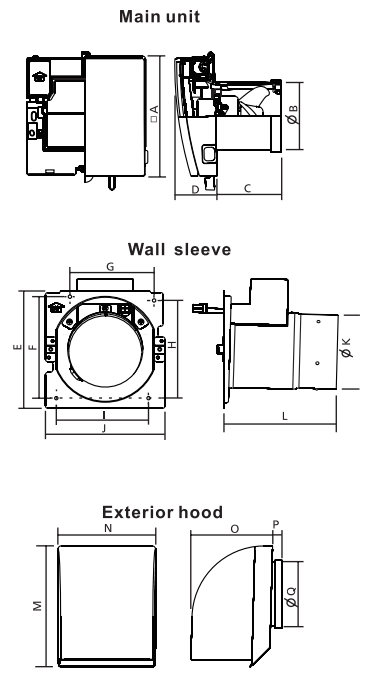

Unit: inches (mm)

A	B	C	D	E	F	G	H	I
6-3/4 (171)	3-3/4 (95)	3-3/4 (95)	2-3/16 (56)	6-1/8 (156)	5-5/16 (135)	4-7/16 (113)	5-1/8 (130)	4-1/2 (115)

J	K	L	M	N	O	P	Q
6-1/4 (159)	3-7/8 (98)	6 (152)	6-7/8 (175)	5-1/2 (140)	4-7/16 (113)	11/16 (17)	3-5/8 (92)

Specifications: WhisperSupply Wall FV-01WS2	
Static Pressure in inches w.g.	0.03
Air Volume (CFM)	10
Noise (sones)	<0.3
Power Consumption (watts)	3
Energy Efficiency (CFM/Watt)	4.7
Speed (RPM)	2662
Current (amps)	0.03
Power Rating (V/Hz)	120/60
ENERGY STAR rated	YES

Performance Curve

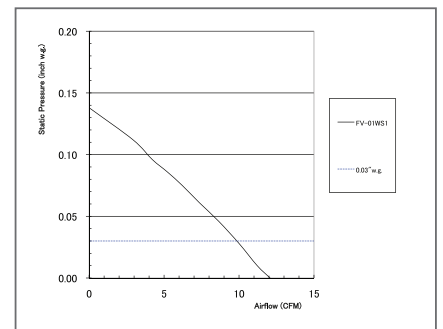

For complete Installation Instructions visit us.panasonic.com/ventfans

Model	Quantity	Comments	Project:
			Location:
			Architect:
			Engineer:
			Contractor:
			Submitted by:
			Date:

Panasonic Eco Solutions North America
Eco Products Division
Two Riverfront Plaza
Newark, NJ 07102

us.panasonic.com/ventfans

