

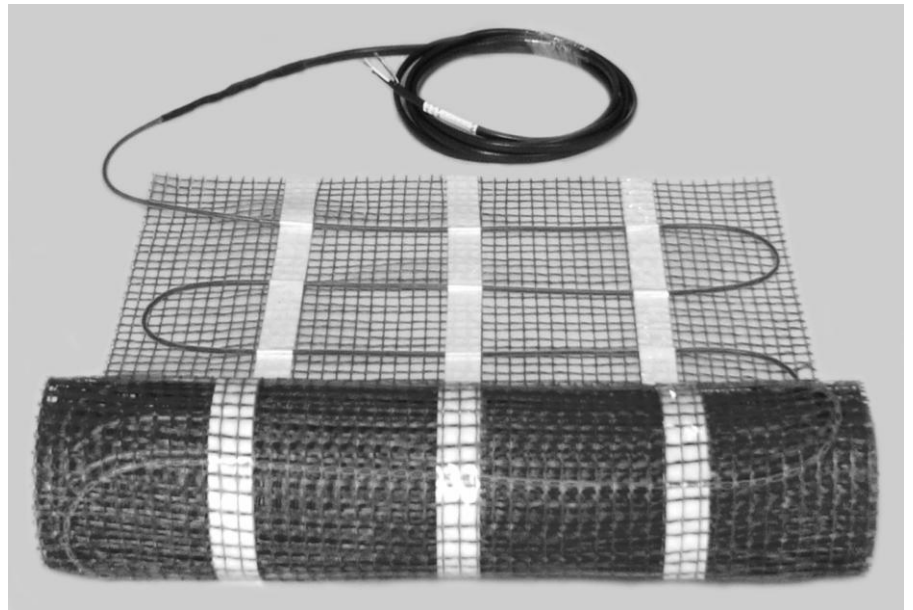

mat series

Electric Floor Heating Mat Systems

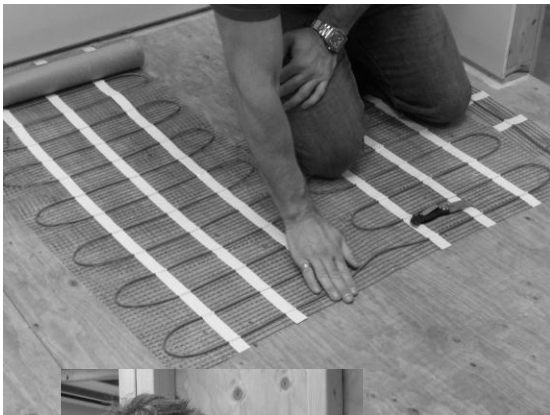

INSTALLATION MANUAL

This installation manual includes factory guidelines for installing King Electric floor heating systems. These guidelines must be followed to ensure warranty coverage. Contact King Electric for any questions regarding proper installation of the heating cable.

IMPORTANT: Save these instructions!



Table of Contents

1.	General Information -----	3
2.	Typical Installations -----	3
3.	Important Safeguards and Warnings _____	4
4.	STEP 1: Inspect and Testing the Cable and Floor Sensor _____	5
5.	Cable Test Log _____	6
6.	STEP 2: Layout Planning and Product Selection -----	7
7.	120 Volt Selection Table -----	9
8.	240 Volt Selection Table -----	9
9.	STEP 3: Thermostat Location -----	10
10.	Materials Required -----	11
11.	STEP 4: Electrical Rough-in New Construction -----	12
12.	STEP 4R: Electrical Rough-in for Remodel -----	13
13.	STEP 5: Installing the Cold Lead -----	14
14.	STEP 6 : Installing the Mat -----	16
15.	STEP 7: Install the Floor Sensor -----	18
16.	STEP 8: Apply Scratch Coat -----	18
17.	STEP 9: Install the Thermostat -----	19
18.	Troubleshooting _____	20

General information

Electric floor heating is a simple, economical way to warm any floor providing years of lasting comfort whether it is used as supplemental or the primary heating source. This installation manual provides guidelines, safety warnings and describes the elements of properly installing the King Electric floor heating system which are:

1. How to design the proper layout for the room.
2. How to select the right product for the application.
3. How to properly install the system.

This installation manual DOES NOT provide detailed information regarding thermostat installation. It is important to thoroughly review the thermostat installation manual included with the thermostat. For additional information regarding any aspect of the King Electric floor heating system, please contact us at:

King Electrical Manufacturing Co.

9131 10th Ave South

Seattle, WA 98108

1-800-603-5464

www.king-electric.com

Typical Installations

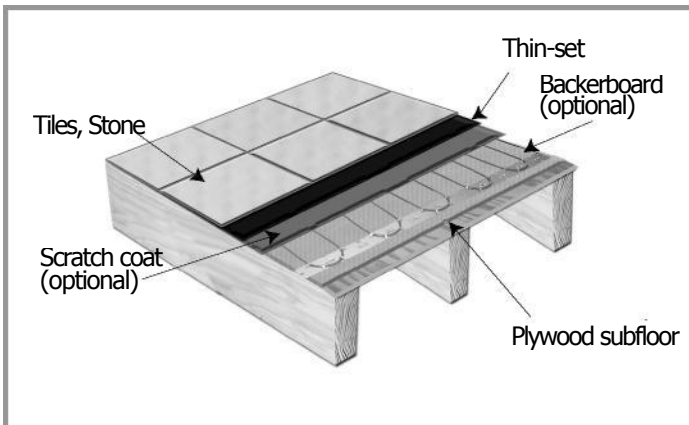

Directly on plywood

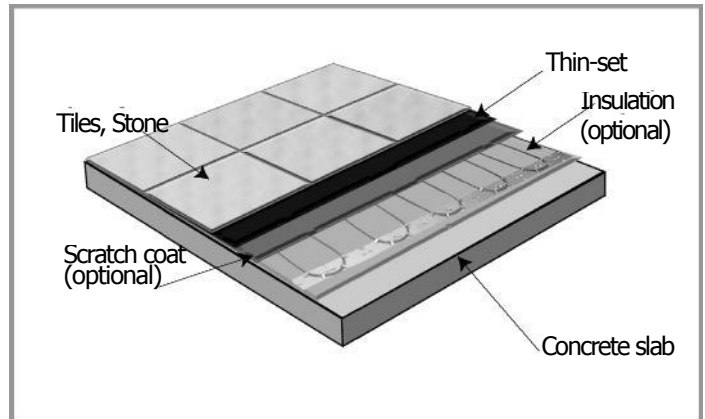

Directly on concrete

Important Safeguards and Warnings

READ AND FOLLOW THE WARNINGS AND INSTALLATION INSTRUCTIONS PROVIDED IN THIS MANUAL. FAILURE TO DO SO COULD RESULT IN ANY OF THE FOLLOWING: CABLE FAILURE, IMPROPER SYSTEM OPERATION, PROPERTY DAMAGE, BODILY INJURY OR DEATH. THE WARRANTY IS INVALID IF THE WARNINGS AND SPECIFIC INSTRUCTIONS ARE NOT FOLLOWED.



WARNING: ELECTRIC SHOCK AND FIRE HAZARD!

1. The instruction manual follows North American standard building construction conventions.
2. An electrical inspector may be required before, during and after the installation. It is recommended to contact your local building department BEFORE beginning the installation.
3. DO NOT energize the mat before installation as it will cause overheating or damage to the cable.
4. Connect mats to rated voltage only. Be sure to size for conductors properly to carry the rated amperage.
5. This product is approved for indoor use only. Minimum installation temperature is 40 F .
6. Use only copper supply wires. Be sure to size for conductors properly to carry the rated amperage.
7. DO NOT cut the blue heating cable or attempt to alter the length in any way. The black cold lead can be shortened, but only at the end of the cable where the power leads are exposed. DO NOT cut at the splice between the cold lead (black wire) and the heating wire. (blue wire)
8. DO NOT install heating cable under any type of floor that requires nailing.
9. Ground fault protection (GFCI) is required when installed in wet environments such as a bathroom. Consult the local electrical and building authority to determine and additional requirements in your area.
10. If the GFCI trips during normal conditions and cannot be reset, consult an electrician for service. NEVER attempt to bypass or disable the GFCI system.
11. When installing cable in shower areas, the cable must be installed under the waterproofing membrane to keep the cables dry.
12. DO NOT drill, nail or cut into any floors that have heating cable installed underneath. This could result in contact with live electrical wires causing electrical shock.
13. DO NOT use staples, nails or similar fasteners directly on the cable. Use only factory the factory recommended system to attach the mat. The use of any other fastening method will void the warranty.
14. Use a smooth plastic trowel only. NEVER bang or drop a tool on the cable. Care should be taken not to nick or gouge cable.
15. DO NOT install the heating cable under a cabinet or other built-in. This will cause the cable to overheat.
16. DO NOT install the heating cable (blue wire) inside a wall. Only the cold lead can go into a wall stud.
17. DO NOT extend the heating cable beyond the room or area that it originates.
18. DO NOT attempt to repair damaged cable without a factory splice kit.
19. DO NOT overlap heating cables. Dangerous overheating will occur.
20. DO NOT allow the cold lead or thermostat sensor to cross or overlap the heating cable.
21. All cables must be completely embedded into a cement based mortar including the cold lead, cold lead splice, heating cable, heating cable tail splice and thermostat sensor with the wire lead.
22. DO NOT bend the cable at sharp right angles. Always maintain a minimum 1" radius.
23. Maintain at least a minimum of 2" between heating cables.
24. Test and record the cable resistance at least 4 times during installation.
25. After installation of the cable, the installer must inspect and remove damaged or defective cables before they are covered or concealed.
26. The installer should mark the appropriate circuit breaker reference label indicating which branch circuit supplies the circuits to those electric space heating cables.
27. These products are to be installed in accordance with ANSI/NFPA 70, National Electrical Code (NEC) and CAN/CSA-C22.1, Canadian Electrical Code, Part I (CEC).
28. Only UL Listed conduit, fittings, and/or other components are to be used.
29. Products are listed for installations with a maximum thermal resistance value of R-1 for floor covering that can be placed on top of your product

STEP 1: Inspecting and testing the cable and floor sensor

1.1 Take the mat out of the box and inspect it for any physical damage.

1.2 Test the insulation and the resistance of the cable and record data in the CABLE TESTING LOG listed on page 6 of this manual. This is test #1.

1.3 The cable and sensor must be tested and recorded a minimum of 4 times during the installation for the warranty to be valid.

Insulation Test:

1.4 This test ensures that the insulation jacket of the cable is not damaged. A low value on the meter indicates the cable has been damaged and must be replaced. Follow the following steps:

- A. Set the multi-meter to read ohms.
- B. Connect the ground wire (braided un-insulated wire) to the black test lead of the multi-meter and the red test lead to both the black and white wires of the cold lead.
- C. The meter should read "OPEN" or "OL". If you get a different reading, the cable is damaged, contact King Electric for support.
- D. Record the readings on the cable tag and in the cable test log.



Resistance test:

1.5 This test measures the resistance of the cable which verifies the continuity (no breaks) and that the cable has the proper wattage rating.

- A. Set the multi-meter to read ohms.
- B. Connect the meter leads to the black and white cold lead wires, DO NOT connect the ground wire.
- C. Compare the resistance reading to the value specified in the product selection table, it should read 10%. If the reading is different, contact King Electrical for support.
- D. Record the readings on the cable tag and in the cable test log.

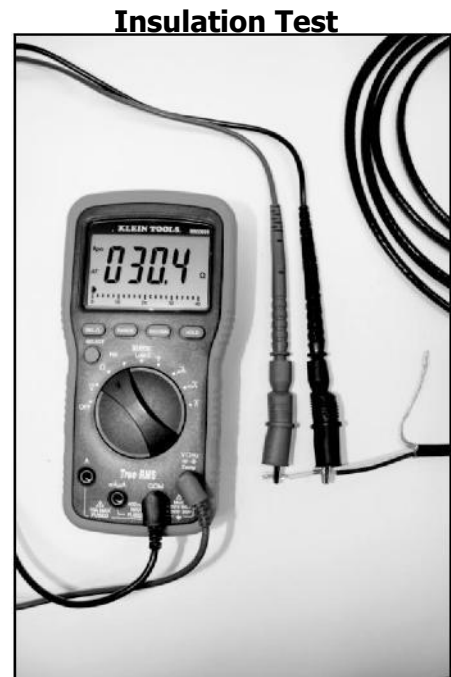

Resistance Test

STEP 1: Inspecting and testing the cable and floor sensor. (continued)

1.6 FLOOR SENSOR TEST:

This test measures the resistance of the floor sensor to verify the integrity of the component.

- A. Set the multi-meter to read ohms.
- B. Connect the multi-meter leads to the floor sensor wires.
- C. The meter should read between 8-25k ohms depending on the ambient temperature when taking the test. If test results are not between 8-25k contact King Electrical for support.
- D. Record the readings on the cable tag and in the cable test log.

Typical sensor values:

55F (13C) _____ 17,000 ohms
65F (18C) _____ 13,000 ohms
75F (24C) _____ 10,000 ohms
85F (20C) _____ 8,000 ohms



Floor Sensor Test

CABLE TEST LOG

Tests must be recorded for warranty	Resistance (+ 10%)	Insulation Test
Model:		
Volts:		
Factory QC Test		
TEST 1. Before installation		
TEST 2. After installation, but before embedding		
TEST 3. After embedding		
TEST 4. After floor tile		

STEP 2: Layout planning and product selection

King Electric heating mats are used to warm interior floors. It is not to be used for exterior applications such as snow melting or roof and gutter applications. It is not to be used in walls or ceilings. Follow these steps in planning the installation:

2.1 Draw the room dimensions on a piece of grid paper.

2.2 Draw in any fixed obstructions such as a shower, bath tub, vanity or counter. The cable is not to be installed under these type of items. In addition, DO NOT run cables into closets or confined areas where heat could build-up.

2.3 Mark the locations of any toilets, heating vents or any other heating appliance. Note on the drawing that the heating cable must be installed at a minimum distance of:

A. 6" from the center of the toilet drain.

B. 8" from heating vents or any other heating appliance.

2.4 Determine the heated area of the floor by subtracting the permanent fixtures. For example: Figure 1.5 the room is 10ft x 10ft equaling 100 square feet. (ft²). The area of each permanent fixture is as

follows:

A. Vanity = 10ft²

B. Toilet = 3ft²

C. Shower = 9ft²

D. Total heated area: $100\text{ft}^2 - 22\text{ft}^2 = 78\text{ft}^2$

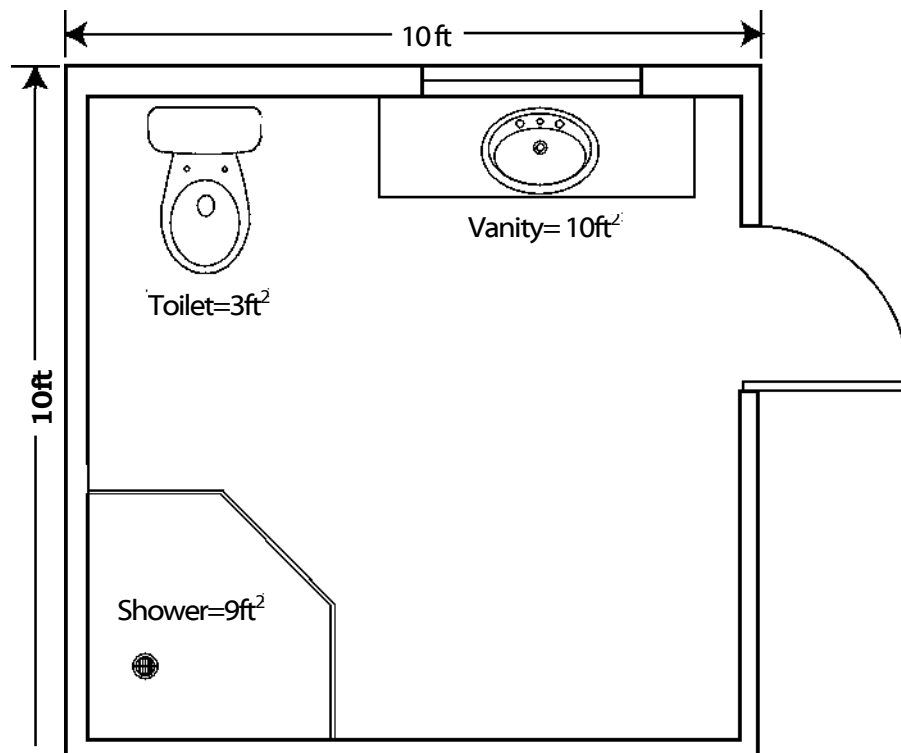

2.5 Border allowance: Heating cable should be installed between 1" and 6" from the perimeter walls, but not more than 1.5" from a kick space vanity, shower, bathtub, counter or doorway. It is not necessary to heat the floor all the way to the wall as it is not typical that people will stand that close to the walls. In addition, the heat will radiate out an additional 2" from where the cable is embedded.

2.6 In most cases simply select the mat kit that is 5% but no more than 10% less that the total square footage of the area to be heated as calculated in the previous step. For example: if the square footage after deduction the fixed obstacles equals 74 ft , then the closest cable kit is 70 ft which is 5.4% less allowing for an unheated border. The next size down is 60 ft which is too small and would not be enough cable to properly heat the room.

2.7 Select either 120 or 240 volt cable depending on the power supply available. DO NOT mix voltages on the same system when more than one cable is used to cover a room.

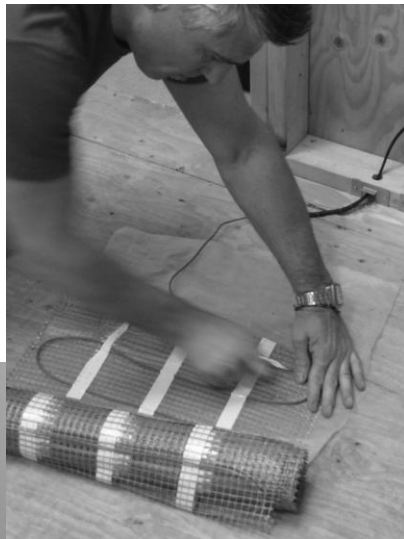

Simple cut and roll installation



STEP 3: Thermostat location and strapping layout (continued)

Product Selection Chart

120V Models

120V Catalog Number	Heated Area		Mat Dimensions		Watts (12W/sq.ft.)	Amps	ohms
	sq.ft.	m ²	in.*ft.	m*m			
FCM1-10	10	0.93	30*4	0.76*1.2	120	1	120
FCM1-15	15	1.39	30*6	0.76*1.8	180	1.5	80
FCM1-20	20	1.86	30*8	0.76*2.4	240	2	60
FCM1-25	25	2.32	30*10	0.76*3.1	300	2.5	48
FCM1-30	30	2.79	30*12	0.76*3.7	360	3	40
FCM1-35	35	3.25	30*14	0.76*4.3	420	3.5	34.3
FCM1-40	40	3.72	30*16	0.76*4.9	480	4	30
FCM1-50	50	4.65	30*20	0.76*6.1	600	5	24
FCM1-60	60	5.57	30*24	0.76*7.3	720	6	20
FCM1-70	70	6.5	30*28	0.76*8.6	840	7	17.1
FCM1-80	80	7.43	30*32	0.76*9.8	960	8	15
FCM1-90	90	8.36	30*36	0.76*11.0	1080	9	13.3
FCM1-100	100	9.29	30*40	0.76*12.2	1200	10	12

240V Models

240V Catalog Number	Heated Area		Mat Dimensions		Watts (12W/sq.ft.)	Amps	ohms
	sq.ft.	m ²	in.*ft.	m*m			
FCM2-20	20	1.86	30*8	0.76*2.4	240	1	240
FCM2-30	30	2.79	30*12	0.76*3.7	360	1.5	160
FCM2-35	35	3.25	30*14	0.76*4.3	420	1.8	137.1
FCM2-40	40	3.72	30*16	0.76*4.9	480	2	120
FCM2-50	50	4.65	30*20	0.76*6.1	600	2.5	96
FCM2-60	60	5.57	30*24	0.76*7.3	720	3	80
FCM2-70	70	6.5	30*28	0.76*8.6	840	3.5	68.6
FCM2-80	80	7.43	30*32	0.76*9.8	960	4	60
FCM2-90	90	8.36	30*36	0.76*11.0	1080	4.5	53.3
FCM2-100	100	9.29	30*40	0.76*12.2	1200	5	48
FCM2-110	110	10.22	30*44	0.76*13.4	1320	5.5	43.6
FCM2-120	120	11.15	30*48	0.76*14.7	1440	6	40
FCM2-145	145	13.47	30*58	0.76*17.7	1740	7.3	33.1
FCM2-160	160	14.86	30*64	0.76*19.6	1920	8	30

* 240 volt cables are approved for 208 volt, but will produce 25% less wattage.

STEP 3: Thermostat location

3.1 Mark the location of the thermostat on the drawing. This is where the cold lead will drop from the wall box and become the starting point for the heating cable as well as where the floor sensor will be installed.

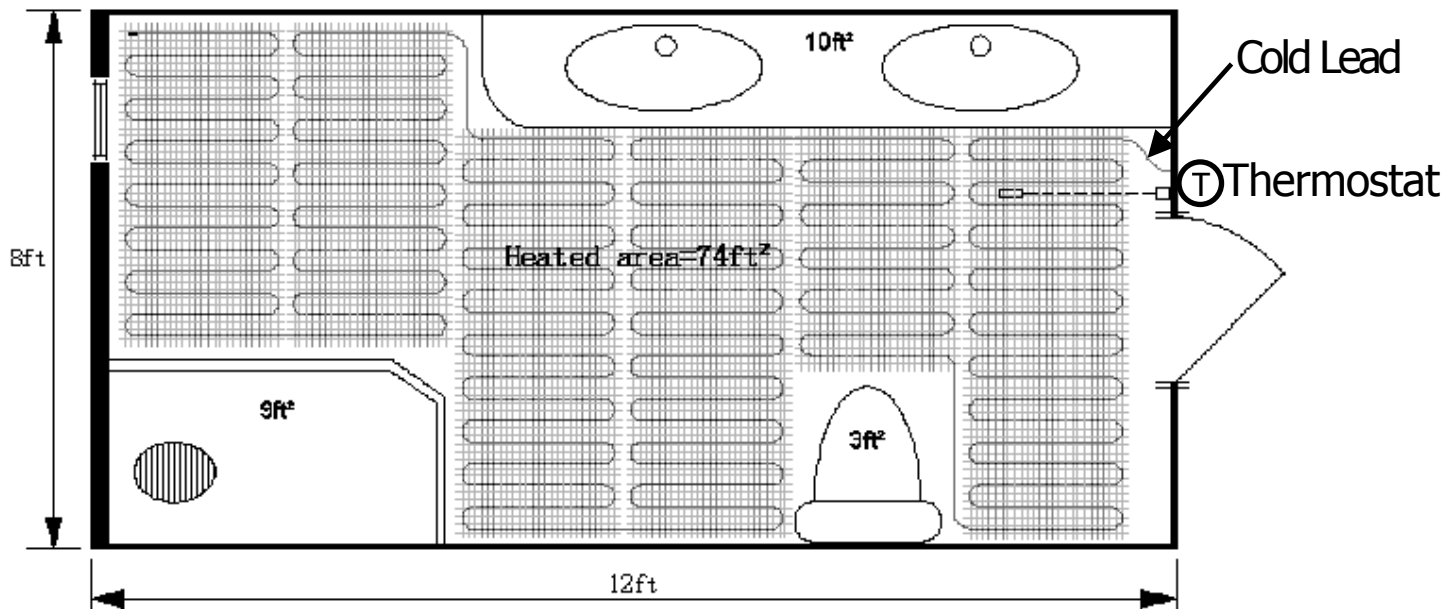

3.2 Determine the direction of the cable runs. It is recommended that the cable run parallel to the wall that the thermostat is mounted. 48 inches. Center straps should be 3 to 4 feet apart.

3.3 On average, a 5 to 10% deduction in heated area will create a 2-4" border. To determine the exact distance to mount the mat from the wall, take the actual room square footage less the selected mat kit less to determine the unheated border. Then take the unheated border and divide it by the perimeter. Now multiply by 12 for the number of inches to mount the mat away from the wall.

A. $10\text{ft} \times 10\text{ft} \text{ room} = 100 \text{ ft}^2$

B. $4\text{ft} \times 10\text{ft} = 40 \text{ ft}^2 \text{ perimeter}$

C. Mat kit selected 90 ft^2

D. $100\text{ft} - 90 \text{ ft} = 10\text{ft} \text{ unheated border}$

E. $10\text{ft} / 40\text{ft} = .25\text{ft}$

F. $.25\text{ft} \times 12\text{in}/\text{ft} = 3'' \text{ from the wall}$

3.4 It is difficult to predict exactly where the heating cable will end, thus it is important to have a buffer zone.

A buffer zone is an area where heating is not essential and if unheated will go unnoticed. This area is also used for any excess cable where a higher heated density will also be un-noticed.

STEP 3: Thermostat location and strapping layout (continued)

Materials required

1. King floor heating mat
 2. King GFCI thermostat
 3. King temperature sensor (included with thermostat)
 4. King instant alert monitor, model FCS11
 5. Electrical box and cable clamps
 6. Wood chisel or router
 7. Multimeter or megometer
 8. Electrical wire connectors and cable fasteners
 9. Nail plate (included with cable kit)
 10. Duct tape
 11. Stapler
 12. Protective glasses
 12. Tape measure
 13. Broom
 14. Felt tip marker
 15. Electrician tools
 16. Electric drill
 17. Plastic trowel
 18. Hammer
 19. Hot glue gun
- For installation on concrete slab add:
20. Double backed tape

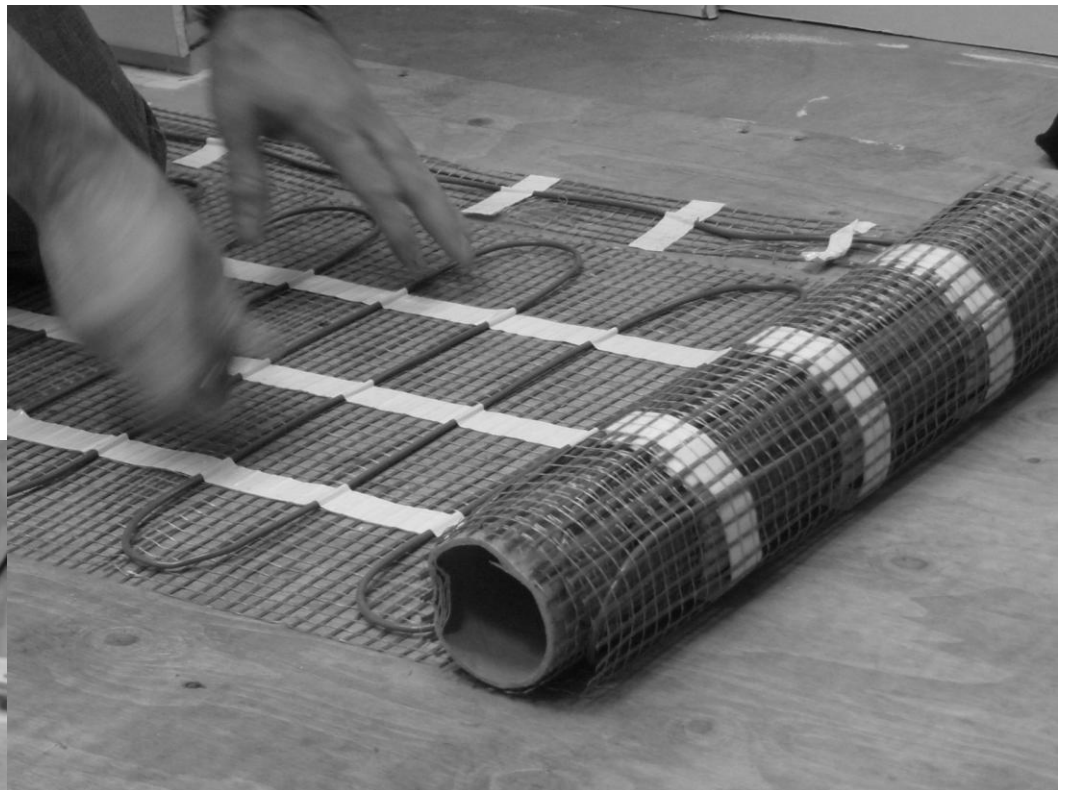

Simple roll-out installation



STEP 4: Electrical rough-in (New construction)

Mount Electrical Box

4.1 Determine the proper location and height (typically 60") for the junction box. The cold lead and the floor sensor lead wires should be in the same stud cavity as the electrical junction box. Install the junction box for the thermostat and run the power supply wires into the box.



Drill Horizontal Hole

4.2 Drill a 3/4" hole 1-1/2" deep horizontally into the sill plate for the cable routing. Drill the hole as close to the bottom of sill plate as possible. Chisel out the bottom of the sill so that the cold lead wire will not create a high spot in the floor when the thin-set is applied.



Drill Vertical Hole

4.3 Drill a 3/4" hole vertically into the sill plate 1-1/2" deep. If installing a floor sensor, drill a second set of holes 4" away in the same stud cavity.

4.4 Clear the cable routing holes of debris and install in the same stud cavity.



Install Nail Plate

4.5 It is recommended to thread a pull string as the cable installation will be done after the drywall is in place. Run a second pull string if a floor sensor is being installed. Otherwise the wires can be fished through the wall with an electrician's fish tape after the drywall is installed.

STEP 4R: Electrical rough-in (For Remodel)

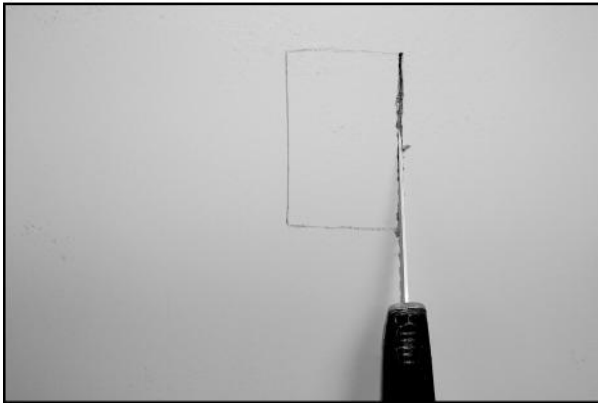

Cut Hole for remodel J-box

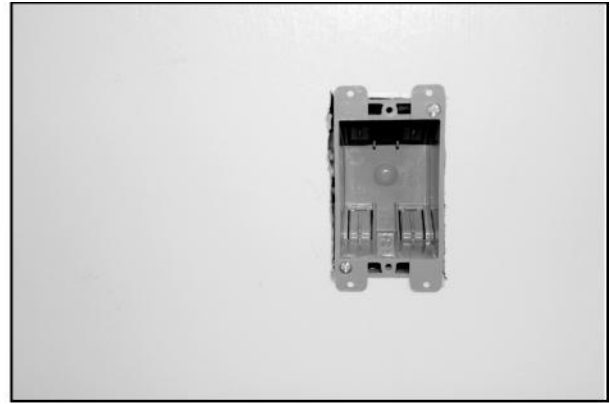

Install remodel J-box

4.1R Determine the proper location and height (typically 60") for the junction box. The cold lead and the floor sensor lead wires should be in the same stud cavity as the electrical junction box.

4.2R Install a remodel type electrical junction box for the thermostat and run the supply power into the box.



4.3R Remove base moldings as needed where the cable routing holes need to be drilled.

4.4R Chisel out a 1-1/2" by 1-1/2" channel into the sill plate 1-1/2" deep. If installing a floor sensor, chisel a second relief 4" away in the same stud cavity.



Install Nail Plate

4.5R Install a nail plate to protect the wires.

STEP 5: Installing the cold lead



Chisel .25" Groove

5.1 Unroll the power leads of the mat up to the factory splice and feed it up the wall into the thermostat junction box. The factory splice **MUST BE** mounted on the floor and **MUST NOT** be installed in the wall.

5.2 Due to the large diameter of the cold lead splice, a .25" deep channel must be cut into the floor to avoid interference with the finished floor. For a wood floor Use a router or wood chisel. For a concrete floor, use An appropriate masonry chisel or power hammer.
Remove any debris to avoid damage to the cable.



Hot Glue Splice

5.3 Secure the cold lead splice into the chiseled channel with hot glue. **DO NOT USE SCREWS OR STAPLES TO SECURE THE COLD LEAD.**

5.4 Secure any loose (blue) heating cable between the start of the run and the location where the cable is first laced through the strapping. Use the single hole straps provided.

IMPORTANT:

THE COLD LEAD SPLICE MUST BE FULLY EMBEDDED IN THE MORTAR. In addition, the cold lead splice Must not be bent. No portion of the cold lead should Enter into a wall or drop through a subfloor.

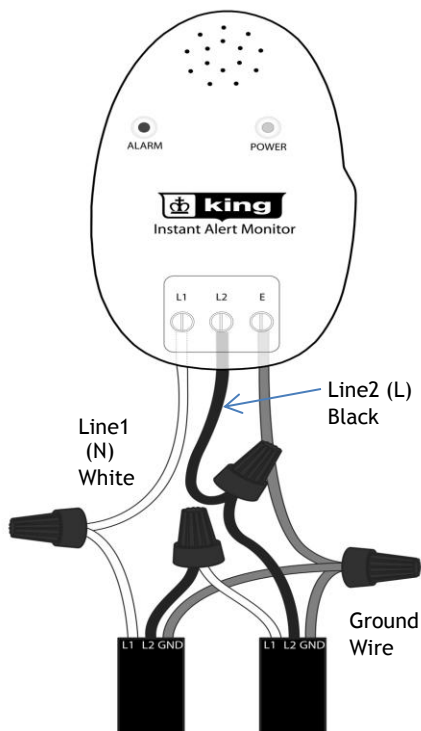

IMPORTANT: Do **NOT** skip this step.

Install Alert Monitor

5.5 Install the cable monitor and leave it connected throughout the entire installation process until the tile has set. If the cable monitor sounds an alarm, stop and check the cable for damage. The cable is only to be repaired with a factory splice kit.

STEP 6: Installation of Mat

Clean floor before starting Installation

6.1 The floor should be swept of all debris including dirt, saw dust, nails and other construction materials.

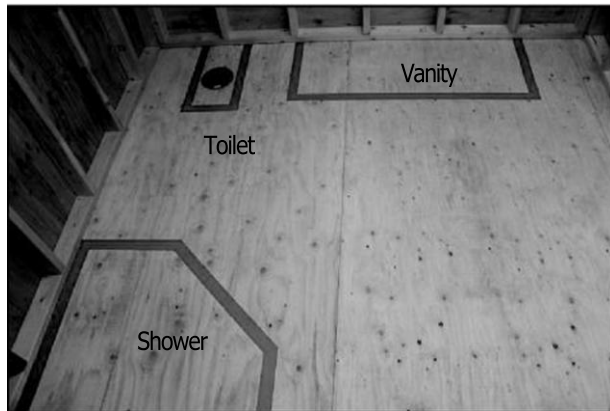

Plan routing of mat.

6.2 Use tape to mark the fixed objects in the room the cable needs to avoid, such as a vanity, shower or bathtub. These areas will remain unheated.

6.3 Plan the cable routing around the fixed objects. It is best to plan the cable runs parallel to the longest wall in the room. Be sure to have a plan for the end of the cable, including an overflow area to place any excess cable. The cable **MUST NOT** be cut.

Test Fit the Mat.

6.4 Roll out the mat, cutting the mesh and flipping it as needed to cover the area that you intend to heat. It is critical that you ensure proper fitting of the mat before securing to the floor. If the mat is too large for the area, it can not be cut shorter and the cable cannot be installed inside a wall, or under baseboards or cabinets. All cable must be embedded in floor mortar.

6.5 Border allowance: Heating cable should be installed between 1" and 6" from the perimeter walls, but not more than 1.5" from a kick space vanity, shower, bathtub, counter or doorway. It is not necessary to heat the floor all the way to the wall as it is not typical that people will stand that close to the walls.

6.6 DO NOT leave gaps between mats. Heat will only radiate out approximately 2" from the cable.

6.5 To ensure maximum coverage of the floor, it will likely be necessary to cut the mesh of the mats to fit odd-shaped areas, such as corners or working around various angles or cabinets. Examples of the different techniques you may need are described below.

CUTTING TECHNIQUES

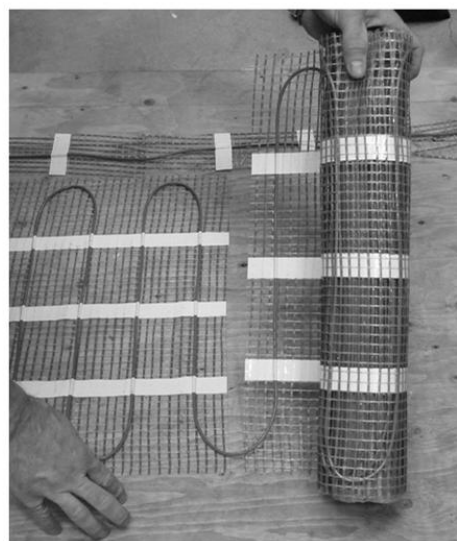

Cut the orange mesh to make turns. Cut away from the blue cable so as to never cut or damage.

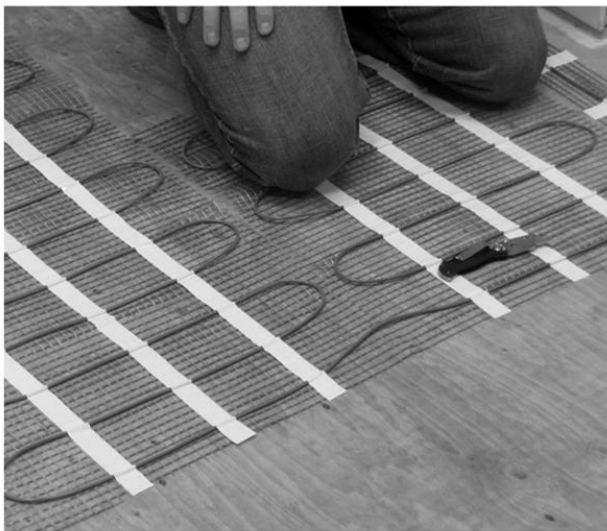

Back-To-Back Turn

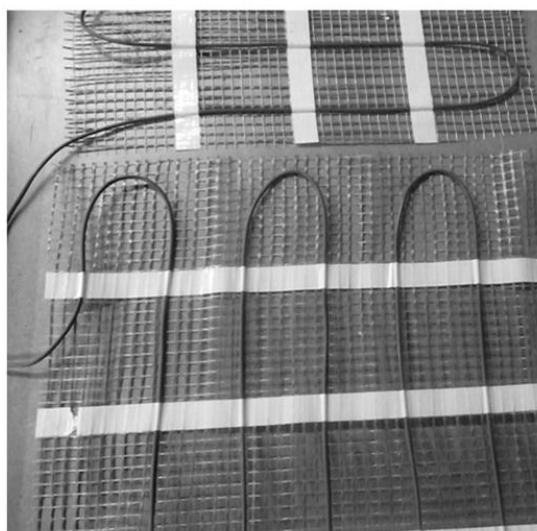

Flip Turn

STEP 7: Install the floor sensor



Position floor sensor halfway between the heating cables

7.1 The floor sensor must be positioned exactly halfway between two heating cables to accurately read the floor temperature. Place the sensor bulb at least 12" into the heated area. Mark the spot on the floor where the sensor bulb will be located.

7.2 To make sure the sensor bulb will not create a high spot in the floor, chisel a .25" channel into the floor and lay the sensor bulb into the channel. Apply hot glue to secure the bulb into place.



Test cable before embedding

7.3 Use a fish tape or pull string to pull the sensor wire to the electrical box, but not in the box.

IMPORTANT TEST 1: Test the cable resistance, cable insulation and floor sensor now that the cable is installed on the floor. Record the readings on the cable label and the data table on page 6.

STEP 8: Apply scratch coat

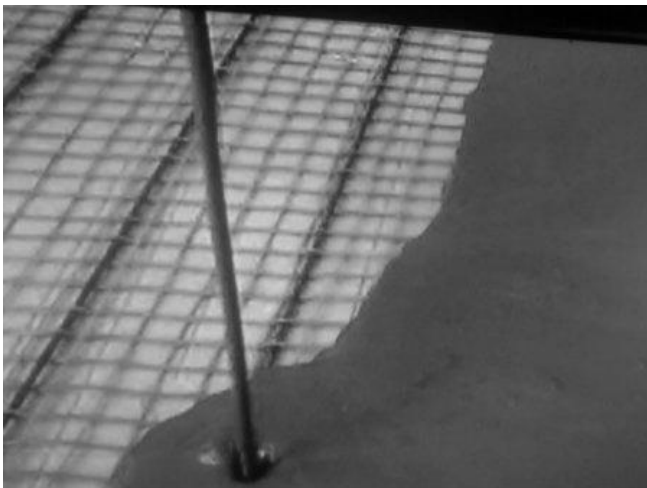

Scratch coat application

8.1 Apply a scratch coat of thin-set or self-leveling mortar uniformly over the entire floor area. Make sure the heating cables are completely embedded. Follow the compound manufacturer's instructions.

8.2 Use a plastic straight edge trowel and cover the entire areas that don't have cable to maintain uniform height.

8.3 Apply the mortar in the same direction of the cable runs to minimize lateral movement.

IMPORTANT TEST 2: TEST THE CABLE RESISTANCE, CABLE INSULATION AND FLOOR SENSOR RESISTANCE TO BE SURE NO DAMAGE OCCURRED DURING THE THIN-SET APPLICATION. RECORD THE READINGS ON THE CABLE LABEL AND IN THE DATA

LOG ON PAGE 6.

STEP 9: Install the wall thermostat

Follow the thermostat manufacturer's instructions.

Example of Thermostat wiring diagram

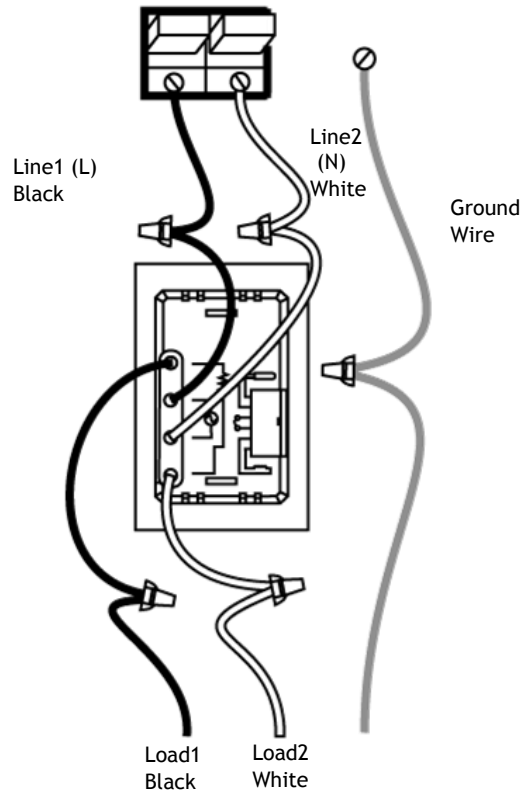

Example of Floor Sensor Wiring

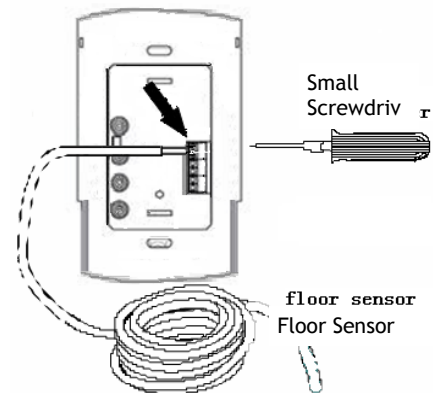

9.1 Before starting any wiring, verify that the power supply is turned off.

9.2 Connect the power supply wires and the load side heating wires.

Follow the thermostat manufacturer's instructions.

9.3 Connect the floor sensor wires to the thermostat. These are low voltage wires and should not enter the line voltage junction box. These low voltage wires typically run through the wall and connect into the face of the thermostat away from the line voltage wires.

CAUTION: Allow mortar compound to completely cure before energizing cable. This will ensure that the setting of the mortar mix will not be compromised by the heat of the cables. Refer to compound manufacturer's instructions for curing times.

Trouble Shooting Guide

Symptom	Probable Cause	Solution
Cable test resistance measurement is wrong.	Meter is out of calibration or inaccurate.	Try another meter.
	Test measurement indicates open or short circuit.	Cable is most likely damaged and must be replaced.
	Measurement is slightly out of specified range.	Room temperature can effect reading, retake the at room temperature between 65F-75F.
	The ohmmeter could be set to the wrong scale.	The typical scale is 200 ohms, unless the cable label is rated for more than 200 ohms.
Floor does not heat up.	The cable is damaged	Measure the resistance, if it reads open or short then it must be repaired. Find the damage cable and have it repaired by a qualified installer using a factory repair kit.
	GFCI is tripped	Reset GFCI control on the thermostat or circuit breaker. If GFCI continues to trip
	No voltage	Check circuit beaker, if it is on then test for voltage at the line side of thermostat.
	Thermostat is not turned on.	Refer to thermostat manual for operating instructions
	Incorrect supply voltage.	A 240V cable supplied with 120V power will not generate sufficient heat. Measure supply voltage with a volt meter.
	Multiple cables wired in series.	Multiple cables must be wired in parallel.
Floor heat does not turn off.	Wiring is incorrect. The control is bypassed.	Refer to the thermostat instructions for proper wiring.
	Defective thermostat or floor sensor.	Replace thermostat and/or floor sensor.
Control is not working properly.	Check for proper supply voltage, check program, check floor sensor, check for loose connections .	Refer to the thermostat instructions for proper wiring. Replace thermostat if found to be defective.
GFCI false trips	More than one GFCI on circuit.	Verify that there is only one GFCI on circuit.
	Electric motor or ballast is sharing the circuit.	The floor heat must be on a dedicated circuit, run a new circuit.

King Electrical Mfg. Company will repair or replace, without charge to the original owner, any heating cable found to be defective or malfunctioning within the 20 year warranty. In Case of Product Failure: Contact King Electrical Mfg. Co. at 800.603.5464. The owner will be required to provide, within the designated warranty period, the following information: model number, date of purchase, and a complete description of the problem encountered with product. Upon receipt of the aforementioned, the company will reply to the owner within a period not to exceed fifteen (15) working days, and will provide the action to be taken by owner. Terms: This warranty requires the owner or his agent install the equipment in accordance with the National Electrical Code, any other applicable heating or electrical codes and the manufacturer's installation instructions. It further requires that reasonable

and necessary maintenance be performed on the unit. Failure of proper maintenance by owner will void the warranty in its entirety. The company is not liable for any actions it deems to be abuse or misuse of the product. The customer shall be responsible for all costs incurred in the removal or reinstallation of products, including, but not limited to, labor costs, and shipping costs incurred to return products to King Manufacturing. At their discretion, King Manufacturing will decide to either repair or replace the product, with no charge to the owner, with return freight paid by King. The Company shall not be liable for consequential damages arising with respect to the product, whether based upon negligence, tort, strict liability or contract. No other written or oral warranty applies, nor any warranties by Representatives, Dealers, Employees of King or any other person. King Manufacturing can be contacted by phone at 206.762.0400, fax 206.763.7738 or website www.king-electric.com. The company's minimum liability shall not in any case exceed the list price for the product claimed to be defective.