

Midget Twist-Lock® Devices
 15A, 125V AC, 2 Pole, 3 Wire Grounding
 Flanged Inlet

HUBBELL

Features

- Stainless Steel mounting flange
- High heat resistant phenolic base

Ordering Information

Description	Terminals	UPC	Catalog Number
Stainless steel flanged inlet.	Exposed	783585237794	HBL7595

Listings

Listed to UL 498
 Certified to CSA C22.2 No.42

Specifications

Flange	Stainless Steel
Base	Phenolic
Blades	Brass
Terminal Screws	#5-40 Brass

Performance

Electrical	
Current Interrupting	Certified for current interrupting at full rated current
Dielectric Voltage	Withstands 2,000V minimum
Mechanical	
Terminal Accommodation	#18 AWG - #14 AWG solid or stranded copper wire only.
Terminal Identification	Terminals identified in accordance with UL 498
Environmental	
Flammability	HB or better per UL94/CSA 22.2 No.0.17
Moisture Resistance	IP20 Suitability
Operating Temperatures	Maximum Continuous 75°C; Minimum -40°C (w/o impact)

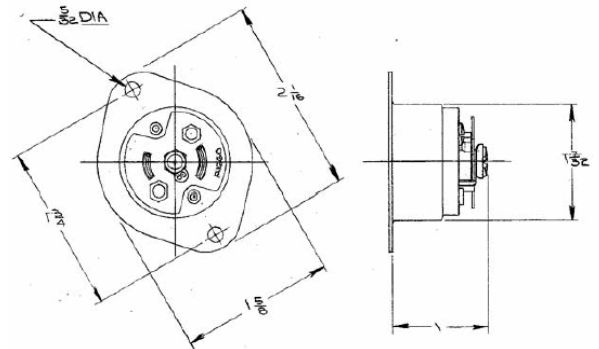

Accessories

Valise® Connector	HBL7593V
Connector	HBL77593
Angled Connector	HBL7571

Resources

Customer Use Drawing
 eCatalog

Dimensions in Inches (mm)

Hubbell Wiring Device-Kellems • Hubbell Incorporated (Delaware) • 40 Waterview Drive • Shelton, CT 06484

Phone (800) 288-6000 • Fax (800) 255-1031 • Specifications subject to change without notice.

