

Ground Fault Receptacles

"Buy American Compliant"

HUBBELL

Hubbell Commercial LED & Tamper-Resistant/Weather-Resistant Ground Fault Receptacles
Buy American Provision 1605 of ARRA Compliant – Assembled in U.S.A. (Newtown, CT)!



GFTR20IU

10kA Short Circuit Current Rating

Limits improper access to energized contacts

- Patented shutter design for tamper resistant protection

No power at face if reverse wired

- Open circuit condition eliminates false assumption of protection at face

Ground fault indicator

- Flashing **RED** indicates device has lost capability to provide protection

Installation ease

- Internal back wiring
- Automatic grounding feature
- Captive mounting screws



Armed Forces



Federal Projects



Hospitals

Advantages

Assembled in the United States of America

Molded in U.S.A. – Wallplate

Tamper and Weather Resistant

Benefits

The U.S.A. GFR product line meets the #1 criterion for "Buy American". These products are fully compliant for utilization of "economic stimulus" dollars (Exclusive).

Included with device and is manufactured in the U.S.A. (Exclusive).

All Hubbell "Tamper Resistant" GFCI receptacles are also rated "Weather Resistant" as a standard bonus feature. Competitive devices require an additional part number and cost for a "WR" version (Exclusive).

Ground Fault Receptacles

"Buy American Compliant"

HUBBELL



GFCI LED "Buy American" Compliant, "U.S.A. Domestic End Product"

Description	Color	Standard Receptacles		Hospital Grade ●	
		15A 125V	20A 125V	15A 125V	20A 125V
Impact resistant flush nylon face, back and side wired, automatic grounding clip, LED, assembled in the U.S.A.	Almond	GF15ALLU	GF20ALLU	GFR8200HALLU	GFR8300HALLU
	Black	GF15BKLU	GF20BKLU	GFR8200HBKLU	GFR8300HBKLU
	Brown	GF15LU	GF20LU	GFR8200HLU	GFR8300HLU
	Gray	GF15GYLU	GF20GYLU	GFR8200HGYLU	GFR8300HGYLU
	Ivory	GF15ILU	GF20ILU	GFR8200HILU	GFR8300HILU
	Light Almond	GF15LALU	GF20LALU	GFR8200HLALU	GFR8300HLALU
	Red	GF15RLU	GF20RLU	GFR8200HRLU	GFR8300HRLU
	White	GF15WLU	GF20WLU	GFR8200HWLU	GFR8300HWLU

GFCI LED Tamper and Weather Resistant "Buy American" Compliant, "U.S.A. Domestic End Product"

Description	Color	Standard Receptacles		Hospital Grade ●	
		15A 125V	20A 125V	15A 125V	20A 125V
Tamper and Weather Resistant, impact resistant flush nylon face, back and side wired, automatic grounding clip, LED, assembled in the U.S.A.	Almond	GFTR15ALU	GFTR20ALU	GFR8200HALTRU	GFR8300HALTRU
	Black	GFTR15BKU	GFTR20BKU	GFR8200HBKTRU	GFR8300HBKTRU
	Brown	GFTR15U	GFTR20U	GFR8200HTRU	GFR8300HTRU
	Gray	GFTR15GYU	GFTR20GYU	GFR8200HGYTRU	GFR8300HGYTRU
	Ivory	GFTR15IU	GFTR20IU	GFR8200HITRU	GFR8300HITRU
	Light Almond	GFTR15LAU	GFTR20LAU	GFR8200HLATRU	GFR8300HLATRU
	Red	GFTR15RU	GFTR20RU	GFR8200HRTRU	GFR8300HRTRU
	White	GFTR15WU	GFTR20WU	GFR8200HWTRU	GFR8300HWTRU



GFCI Receptacle Specifications per GFCI Products Listed

Trip Level	4 to 6 mA.
Trip Time	.025 sec. nominal.
Frequency	60 Hz.
Voltage	120V AC +10% - 15%.
Amperage	15A/20A, 20A Feed Thru.
Maximum Interrupting Capacity	10,000A.
Operating Temperature	-35°C to 66°C or -30°F to 150°F.
Maximum Humidity	95%.
Listings and Standards	Meets UL498 for receptacles, UL943 Class A for GFCIs UL File E41978. CSA Certified.
Codes	Meets all NEC® and CEC requirements.

GFCI Dimensions

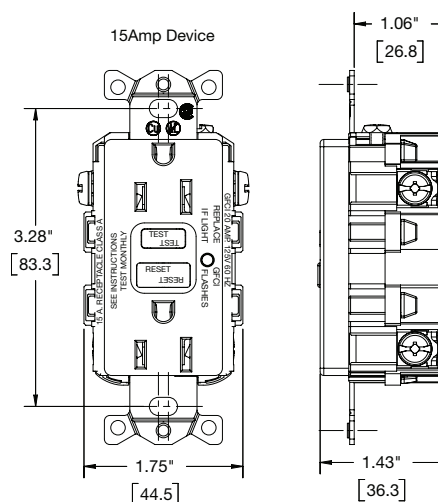

NEC® is a registered trademark of the National Fire Protection Association (NFPA).

HUBBELL®
Wiring Systems

www.hubbell-wiring.com
www.hubbell-premise.com



Hubbell Wiring Device-Kellems • Hubbell Incorporated (Delaware) • 40 Waterview Drive • Shelton, CT 06484 • Phone (800) 288-6000 • FAX (800) 255-1031
Hubbell Premise Wiring • Hubbell Incorporated (Delaware) • 14 Lord's Hill Road • Stonington, CT 06378-0901 • Phone (800) 626-0005 • FAX (860) 535-8328

Printed in U.S.A. Specifications subject to change without notice.

WLDG001 12/10