

VG-A-PD

VG Series Vehicle Garage Luminaire – Pendant Mount

Product Description

Cree VG Series parking garage luminaires are designed to deliver optimal, low glare illumination by intelligently combining an in-house designed optical system consisting of indirect view LEDs, a highly efficient internal reflector and a precisely designed optical lens. Architectural design, quick and easy installation and low total cost of ownership makes the VG Series ideal for both new and existing parking garages. Pendant mount includes 66" (1,676mm) wires out of fixture and is intended to be mounted by 3/4 IP pendant (by others).

Performance Summary

Initial Delivered Lumens: Up to 3,820 Lumens (Type V Medium),
Up to 3,870 Lumens (Type V Wide)

Input Power: 50 Watts

Optics: Type V Medium Distribution or Type V Wide Distribution

Made in the U.S.A. of U.S. and imported parts

CRI: Minimum 70 CRI

CCT: 5700K (+ / - 500K), 4000K (+ / - 300K)

Limited Warranty[†]: 10 years on luminaire / 10 years on Colorfast DeltaGuard[®] finish

Accessories

Field Installed Accessories	
VG-BS* Bird Shroud	VG-PS Perimeter Shroud
* Specify finish color	XA-SENSREM Hand-Held Remote - For successful implementation of the programmable multi-level option, a minimum of one hand-held remote is required

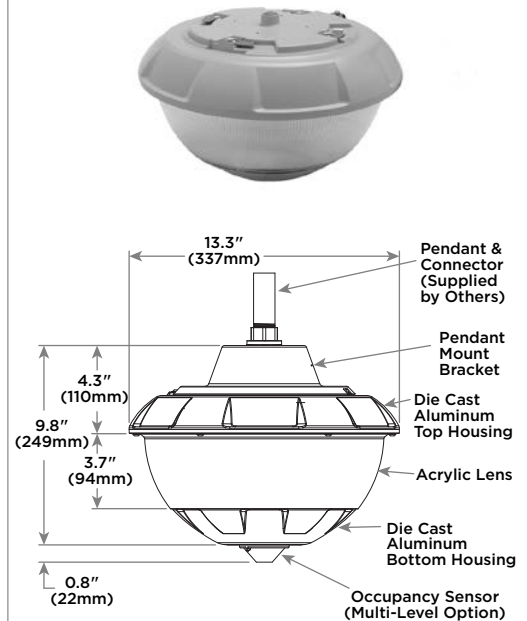

Ordering Information

Example: VG-A-PD-5M-A-40K-UL-BK-OPTIONS

VG	A	PD		A					
Product	Version	Mounting	Optic	Input Power Designator	CCT	-	Voltage	Color Options	Options
VG Vehicle Garage Series	A	PD Pendant	5M Symmetric Medium 5W Symmetric Wide	A 50W	40K 4000K 57K 5700K	- US * Canada	UL Universal 120-277V 34 347V* 48 480V*	BK Black BZ Bronze PB Platinum Bronze SV Silver WH White	DIM 0-10V Dimming - Control by others - Refer to dimming spec sheet for details - Can't exceed specified input power ML Multi-Level - Refer to ML spec sheet for details - Includes occupancy sensor and ambient light sensor PML Programmable Multi-Level - Refer to PML spec sheet for details - Includes occupancy sensor and ambient light sensor TP Tamper Proof Screws - Lens is attached to casting with six tamper proof screws

[†] See www.cree.com/lighting/products/warranty for warranty terms

* 347 and 480V utilizes magnetic step-down transformer. For input power for 347 and 480V, refer to the Lumen Output, Electrical, and Lumen Maintenance data table below



Rev. Date: 11/21/13



Product Specifications

The VG parking garage luminaire provides unprecedented glare control, consistent lighting uniformity, architectural design and low total cost of ownership. Pendant mount includes 66" (1,676mm) wires out of fixture and is intended to be mounted by 3/4 IP pendant (by others).

OPTICAL SYSTEM

- Indirect LED array eliminates direct view of highly efficient LEDs
- Precision engineered optical lens provides maximum low glare light distribution
- Internal white or specular optical reflectors provides choices of Type V Medium or Type V Wide distribution
- Comprehensive optical system provides consistent uniformity

CONSTRUCTION & MATERIALS

- Pendant mount includes 66" (1,676mm) wires out of fixture and is intended to be mounted by 3/4 IP pendant (by others)
- See specific spec sheets for surface, j-box, hook and trunnion mount
- Low profile, lightweight design provides ease of installation
- Constructed of rugged die cast aluminum with integral, weathertight LED driver compartments and high performance heat sink
- Exclusive Colorfast DeltaGuard® finish features an E-Coat epoxy primer with an ultra-durable powder topcoat providing excellent resistance to corrosion, ultraviolet degradation and abrasion. Silver, black, bronze, platinum bronze and white are available

ELECTRICAL SYSTEM

- **Input Voltage:** 120-277V, 347V, or 480V, 50 / 60Hz, Class 2 drivers
- **Power Factor:** > 0.9 at full load
- **Temperature Rating:** Designed to operate in temperatures -40°C to +40°C
- **Total Harmonic Distortion:** < 20% at full load
- Integral 6kV surge suppression protection standard
- To address inrush current, slow blow fuse or type C / D breaker should be used

REGULATORY & VOLUNTARY QUALIFICATIONS

- cULus Listed
- Suitable for wet locations
- Suitable for operation in ambient not exceeding 40°C
- Enclosure rated IP66 per IEC 60529
- Product qualified on the DesignLights Consortium™ ("DLC") Qualified Products List ("QPL")
- 6kV surge suppression protection tested in accordance with IEEE / ANSI C62.41.2
- Meets Buy American requirements within ARRA

Photometry

All published luminaire photometric testing performed to IESNA LM-79-08 standards by a NVLAP certified laboratory.

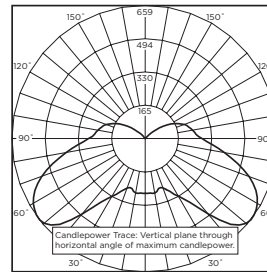

ITL Test Report #: 78019
VG-A-5M-A-40K-UL
Initial Delivered Lumens: 3,776

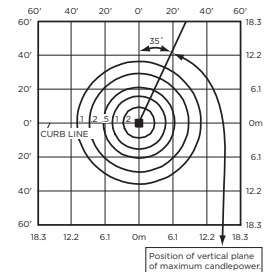

VG-A-5M-A-40K-UL
Mounting Height: 10' (3.0m) A.F.G.
Initial Delivered Lumens: 3,710
Initial FC at grade

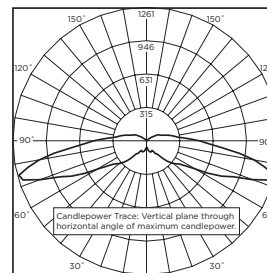

CESTL Test Report #: 2013-0219
VG-A-5W-A-40K-UL
Initial Delivered Lumens: 3,769

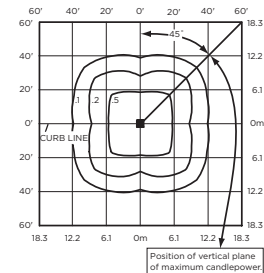

VG-A-5W-A-40K-UL
Mounting Height: 10' (3.0m) A.F.G.
Initial Delivered Lumens: 3,760
Initial FC at grade

Weight

Weight
14.5 lbs (6.6kg)

Lumen Output, Electrical, and Lumen Maintenance Data

VG Vehicle Garage Luminaire													
Optic	5700K		4000K		System Watts 120-277V	System Watts 347-480V	TOTAL CURRENT						50K Hours Projected Lumen Maintenance Factor @ 15°C (59°F)***
	Initial Delivered Lumens*	BUG Ratings** Per TM-15-11	Initial Delivered Lumens*	BUG Ratings** Per TM-15-11			120V	208V	240V	277V	347V	480V	
5M	3,820	B2 U4 G2	3,710	B2 U4 G2	50	52	0.43	0.25	0.22	0.19	0.15	0.11	91%
5W	3,870	B2 U3 G3	3,760	B2 U3 G3	50	52	0.43	0.25	0.22	0.19	0.15	0.11	91%

* Actual production yield may vary between -4 and +10% of initial delivered lumens
 ** For more information on the IES BUG (Backlight-Uplight-Glare) Rating visit www.iesna.org/PDF/Erratas/TM-15-11BugRatingsAddendum.pdf
 *** For recommended lumen maintenance factor data see TD-13. Calculated L70 based on 6,000 hours LM-80-08 testing; > 150,000 hours

