

# BR40 Series

LED Reflector Lamps

## Product Description

At Cree®, we believe in better lighting. Better light is beautiful light. But it's more than just beautiful. It is light that makes you feel more productive, more relaxed and safer. Better light changes everything. That's why the new and improved Cree LED bulbs feature high color rendering that enhances your space and makes the colors of your décor appear vibrant, richer and more natural – true colors the way they are meant to be experienced.

The Cree LED BR40 flood light casts a beautiful light that looks and lights like the incandescent bulbs you love. Dimmable with most standard dimmers, Cree LED BR40 flood lights shine wide and bright, while using at least 85% less energy and are designed to deliver up to 25,000 hours of light for your home or business. The perfect replacement for incandescent bulbs in track and recessed fixtures at a price you can afford, Cree LED bulbs pay for themselves quickly and then pay you year after year.

## Performance Summary

**Lamp Delivered Light Output:** 1,120 - 1,800 lumens

**Input Power:** 12.0-12.5 watts (85W equivalent), 21.5 watts (120W equivalent)

**CRI:** 85 CRI (85W equivalent), 90 CRI (120W equivalent)

**CCT:** 2700K, 5000K (85W Only)

**Limited Warranty\*:** 5 years Commercial use

**Lifetime:** Designed to last at least 25,000 hours

**Dimming:** Dimmable to 5% with select dimmers

ENERGY Star® Certified

Must order in multiples of master carton (MC) quantities; MC = (5) Single-Lamp Cartons

\*See <http://lighting.cree.com/warranty> for warranty terms

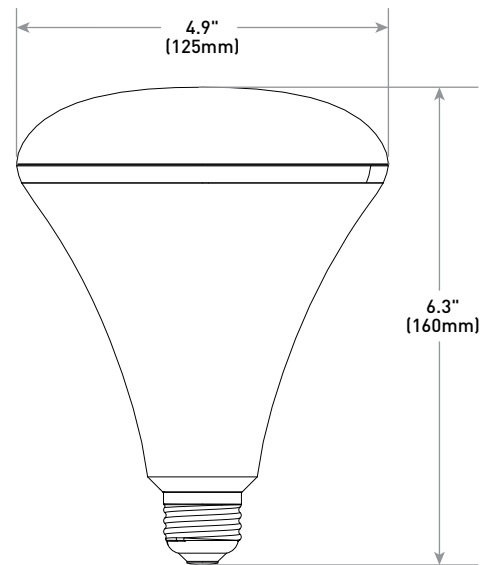

## Ordering Information

Example: BR40-85W-27K-U1

BR40						U1
Product	Watt Equivalent	CCT	Voltage	Base	CRI	Packaging Options
BR40	85W 85 Watt, 1,120 lumens 120W 120 Watt, 1,800 lumens - Available in 27K only	27K 2700K 50K 5000K	Blank 120 Volt	Blank E26 (screw base)	Blank 85 CRI (85W equivalent); 90 CRI (120W equivalent)	U1 Single-Lamp Carton Master Carton = (5) Single-Lamp Cartons



US: [lighting.cree.com](http://lighting.cree.com)



T (800) 236-6800 F (262) 504-5415



Rev. Date: V6 07/19/2017

Canada: [www.cree.com/canada](http://www.cree.com/canada)



T (800) 473-1234 F (800) 890-7507

## BR40 Series LED Reflector Lamps

### Product Specifications

#### CONSTRUCTION & MATERIALS

- BR40 reflector bulb design weighs
- 85W equivalent weighs 10.1 ounces (286g); 120W equivalent weighs 15.0 ounces (426g)
- Reflector bulb meets ANSI standards for BR40 dimensions
- Uses a standard E26 screw base
- Mercury free
- **Dimensions:** 6.5" H x 5.0" W x 5.0" D (Single-Lamp Carton); 6.0" H x 12.0" W x 15.75" D (Master Carton)

#### OPTICAL SYSTEM

- Plastic lens offers increased optical spread

#### ELECTRICAL SYSTEM

- **Power Factor:** > 0.9 nominal
- **Input Voltage:** 120V, 60Hz
- **Dimming:** Dimmable to 5% with select dimmers. Refer to <https://www.creelink.com/viewcontent.asp?qv=1&docid=5344> for additional details
- **Operating Temperature Range:** -25°C - +45°C (-13°F - +113°F)

#### REGULATORY & VOLUNTARY QUALIFICATIONS

- cULus Listed
- Suitable for damp locations, but not for use where exposed directly to weather or water
- Suitable for use in enclosed light fixtures. Lifetime may be reduced if used in air tight enclosures or in insulated ceiling air tight (ICAT) recessed downlight enclosures
- Meets FCC Part 15, Subpart B, Class B standards for conducted and radiated emissions
- ENERGY STAR® certified. Please refer to <http://www.energystar.gov/productfinder/product/certified-light-bulbs/> results for most current information  
BR40-85W-27K-U1  
BR40-85W-50K-U1  
BR40-120W-50K-U1
- RoHS compliant. Consult factory for additional details

### Packaging

(5) Single-Lamp Cartons in Master Carton (5 Total Lamps)



Ordering Number	Single-Lamp Carton UPC	Description	Bulb Type	Watts	CCT	Single-Lamp Cartons per Master Carton	Master Carton ITF-14	Total Lamps per Master Carton	Master Cartons per Pallet Qty	CRI	Lumens	Rated Life (Hrs)
BR40-85W-27K-U1	849665017646	85W Soft White BR40 Equivalent	BR40	12.5	2700K	5	10849665017643	5	70	85	1,120	25,000
BR40-85W-50K-U1	849665017653	85W Daylight BR40 Equivalent	BR40	12.0	5000K	5	10849665017650	5	70	85	1,120	25,000
BR40-120W-27K-U1	849665019046	120W Soft White BR40 Equivalent	BR40	21.5	2700K	5	10849665019043	5	70	90	1,800	25,000