

# Mercmaster™ II HID Luminaires

## High Pressure Sodium and Pulse Start Metal Halide. Mogul Base

UNILETS® for Use with Threaded Metal Conduit.

Class I, Division 2, Groups A, B, C, D †  
Class II, Division 1 and 2, Groups E, F, G †  
Class III  
Fixtures Outside Type (Salt Water)

### Applications

- Enclosed and gasketed HID lighting fixtures for use in tunnels, walkways, bridges, storage facilities, processing plants, parking lots, foundries, manufacturing plants, power plants and other locations where moisture, dirt, dust or corrosive atmospheres are encountered.
- Fixtures suited for Class I, Division 2; Class II, Division 1 and 2; and Class III. Suitable for use in wet and outdoor saltwater locations.
- Wide range of wattages and voltages. Choice of ballasts for 100 W-200 W PSMH; and 50 W-150 W HPS lamps in 120, 208, 240, 277 and 480 voltages.
- Choice of light sources: high pressure sodium and pulse start metal halide.
- Choice of optical assemblies: (1) prismatic globe with or without guard through 200 W; or (2) Type V closed prismatic glass refractor through 200 W. (Types II, III and IV also available through 200 W. Also polycarbonate globes for 100 W max.)
- Choice of mounting hoods: pendant (rigid or flexible), 25° (angle) stanchion, ceiling and wall mounting.
- Porcelain reflector for standard applications and Fiberglass reinforced polyester reflector for installations where luminaire is subject to exceptionally severe corrosive atmospheres.

### Features

- Superior corrosion-resistance: copperfree aluminum mounting hoods, ballasts and guards with epoxy powder coat, inside and out.
- Standard pendant mounting hood for rigid or flexible mounting. Balanced round design automatically hangs plumb when used with flexible hanger.
- Positive sealing. Hinge and bolt construction assures 360° compression at all points on gasket.
- One-piece ballast housing for each component provides even heat dissipation for cooler operation and longer ballast life.
- Heat barrier isolates capacitor from ballast. Standard non-PCB biodegradable capacitors installed in separate compartment.
- Mogul socket is furnished with 392 °F/200 °C welded leads, pre-wired to the ballast.
- Porcelain socket assures trouble-free operation in high ambient installations.
- Guards protect globes from damage. Keyhole slots allow easy installation and are secured with stainless steel screws.
- Prismatic glass globes and glass refractors are standard (plastic refractors also available) and thread directly into fixture housing. Eliminate glare and provide uniform light distribution.
- Vented reflectors result in cooler, dirt-free operation, increased lumen output.
- Reflectors secured to mounting hood with screws (furnished).
- Choice of reflector styles: white porcelain enamel or Fiberglass reinforced polyester; standard dome or 30° angle.
- Optional photocell provides automatic "on-off" control.
- All Mercmaster mounting hoods have provision for easy field installation of fuses in fixtures (see fuse kit listings).



### Standard Materials

- Mounting hoods, ballast bodies and guards: copperfree (4/10 of 1% max.) aluminum
- Reflectors: fiberglass reinforced polyester
- Globes: 50 W-100 W, threaded prismatic glass; 150 W, 175 W and 200W, threaded heat-resistant prismatic glass
- Refractors: 50 W to 150 W, heat-resistant prismatic glass and plastic; 175 W to 200 W, prismatic glass

### Standard Finishes

- Mounting hoods, ballast bodies, guards: epoxy powder-coat finish. Two-coat baked finish, electrostatically applied for complete uniform surface protection
- Polyester reflectors: natural finish

### Options

- Fuses for fixtures. For fuse kits see *Electrical Specifications and Fuse Kits* page.
- MH fixtures for Quartz Auxiliary lamps. Relay switch installed in fixture when specified. Add suffix **-MTE** to fixture catalog number for 120 V through 277 V, and suffix **-480E** to fixture catalog number for 480 V fixture.
- Smart Hot Restrike emergency option, available for 50 W-150 W HPS only. Add suffix **-SR**. See *50 W, 70 W, 100W, 150 W HPS* page.
- Hot Restrike option add suffix **-R**.
- Smart Starter available for HPS and PSMH. Add suffix **-S**.

### Certifications and Compliances

- UL Standard: UL 1598, UL 1598A, UL 844
- UL Listed: E10444

† For specific Class I suitability of each fixture listed, see *Thermal Suitability*.

‡ For 175 W and 200 W fixtures, use 12" refractor only for Groups E, F and G. Heat-resistant glass globe supplied with 175 W and 200 W fixtures.

**Note:** Fixtures equipped with optional photocell or quartz auxiliary lamp do not comply with UL requirements and are not suitable for use in classified locations.

# Mercmaster™ II HID Luminaire Accessories

## High Pressure Sodium and Pulse Start Metal Halide. Mogul Base

Screws furnished to Fasten Reflectors to Ballast Body. Refractors Thread Directly into Ballast Body.

Lighting

LIGHTING: ENCLOSED AND GASKETED – AREA – HID







		Description	Catalog Number
<b>Prismatic Glass Globes</b>			
	Clear Heat-Resistant		<b>VPGL-2HR</b>
	Amber		<b>VPGL-2AM</b>
	Blue		<b>VPGL-2BL</b>
	Green		<b>VPGL-2GR</b>
	Red		<b>VPGL-2RE</b>

<b>Coated Prismatic Tuff-Skin® ✦ Glass Globes</b>			
	For use in areas where fixture is subject to extreme thermal shock	Clear Heat-Resistant	<b>VPGL-2HRT</b>

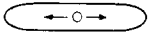
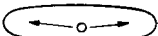
<b>Polycarbonate Globes – Impact-Resistant Ⓢ</b>			
	Use 100W Lamp max.; do not use in ambients exceeding 77 °F/25 °C	Clear Amber Green Red	<b>VPGL-2PL</b> <b>VPGL-2AMPL</b> <b>VPGL-2GRPL</b> <b>VPGL-2REPL</b>

Light Distribution	IES/NECA Distribution Curves	8" Glass (50–200 W Ⓢ)	12" Glass (50–200 W Ⓢ)	12" Polycarbonate (50–175 W Ⓢ)
--------------------	------------------------------	-----------------------	------------------------	--------------------------------

### Closed Prismatic Refractors – 50 W-200 W Ⓢ

	NEMA I		<b>LPG-R1</b>	–	–
	NEMA II		–	<b>LPRF-2CG</b>	<b>LPRF-2CP</b>
	NEMA III		<b>LPG-R3</b>	–	<b>LPRF-3CP</b>
	NEMA IV		–	–	<b>LPRF-4CP</b>
	NEMA V		<b>LPG-R5</b>	<b>LPRF-5CG</b>	<b>LPRF-5CP</b>

Ⓢ Polycarbonate globes are shatter-resistant – for use in processing plants, canneries, dairies, bakeries or anywhere broken glass would prove a hazard. Ideally suited for areas where vandalism, high replacement and high maintenance costs are a problem. Do not use in ambients exceeding 77 °F/25 °C. For burning in vertical base-up positions only.

✦ Registered trademark of Thomas Manufacturing Corporation, Parkton, Md. It is recommended that guards be used with these globes.







Ⓢ 150 W max. for HPS.

Ⓢ 100 W max. for MH.

# Mercmaster™ II HID Luminaire Accessories and Weights

## High Pressure Sodium and Pulse Start Metal Halide. Mogul Base

Screws furnished to Fasten Reflectors to Ballast Body. Refractors Thread Directly into Ballast Body.

		Description	Catalog Number
<b>Guard</b>			
		Guard for Glass Globe	<b>KGU2</b>
<b>Steel Guards for 8" and 12" Refractors</b>			
		Guard for 8" Refractor	<b>LPRG2</b>
		Guard for 12" Refractor	<b>LPBG12</b>
		3 machine screws furnished	
<b>LPRG-2</b>	<b>LPBG-12</b>		
<b>Polyester Reflectors</b>			
		Standard Dome	<b>KR2-ST</b>
		30° Angle	<b>KR2-AN</b>
<b>Standard Dome</b>	<b>30° Angle</b>		
<b>Replacement Gaskets — Silicone Rubber</b>			
		Globe and 12" Refractor Gasket	<b>VPGL-GK</b>
		8" Refractor Gasket	<b>KRF-GK</b>
<b>Photocell (Hazardous)</b>			
		120 Volt	<b>PC120D2</b>
		208 thru 277 Volt	<b>PC247D2</b>

### Mounting Hood Weights

Type	Weight (Lbs/Kg)	Type	Weight (Lbs/Kg)
Pendant	3/1.4	Wall	5/2.3
Ceiling	5/2.3	Stanchion	4/1.8

### Reflectors and Refractors — Weight includes globe and guard

Watts	HPS	PSMH	Standard Dome Reflector		30° Angle Reflector		8" Refractor		12" Refractor	
			Wt. Lbs/Kg	Catalog Number	Wt. Lbs/Kg	Catalog Number	Wt. Lbs/Kg	Catalog Number	Wt. Lbs/Kg	Catalog Number
50, 70	14	—								
100	15	15	2.5/1.1	<b>KR2-ST</b>	2.5/1.1	<b>KR2-AN</b>	5.25/2.4	<b>LPG-R1</b>	13/5.9	<b>LPRF-5CG</b>
150	16	—					5.25/2.4	<b>LPG-R3</b>	13/5.9	
175	—	16					5.25/2.4	<b>LPG-R5</b>	13/5.9	
200		18								

# Mercmaster™ II HID Luminaire Dimensions

High Pressure Sodium and Pulse Start Metal Halide. Mogul Base

UNILETS® for Use with Threaded Metal Conduit.

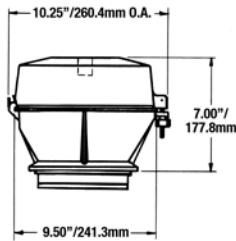

Pendant Mount

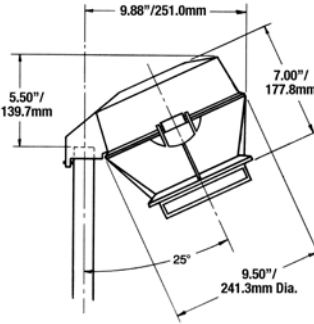

25° Angle Stanchion Mount

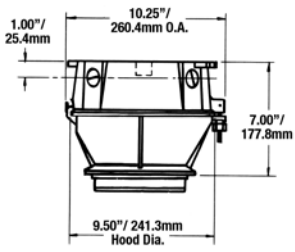
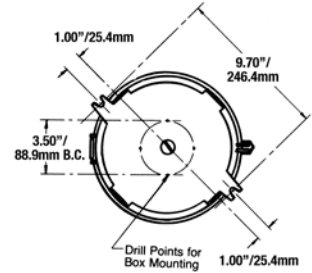

Ceiling Mount

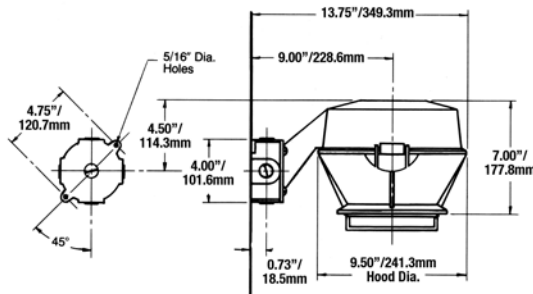

Wall Mount

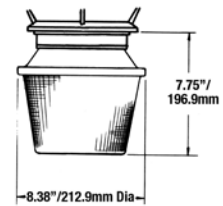

Fixture with 8" Refractor

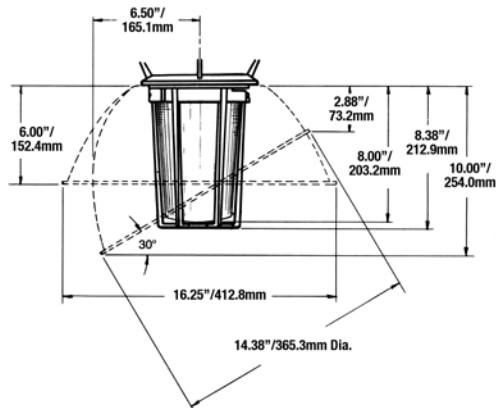

Fixture with Guard and Polyester Reflector

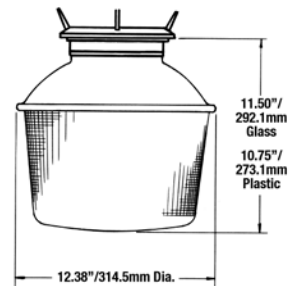

Fixture with 12" Refractor