

REV	DATE	DESCRIPTION	ECO	BY	C.H.K.
P	2019-08-13 01:00:00 EDT	YA25L1BOX ADDED TO SHEET 08	51969	YR	SS

CATALOG NUMBER	STRANDED COPPER CONDUCTOR ACCOMMODATED			BOLT SIZE	METRIC BOLT SIZE	DIMENSIONS							
	CODE (AWG)	NAVY	METRIC SIZE (CLASS 2)			B	C	K DIA.	L	N	O.D.	T REF.	Z MIN.
YA8CL	#8 AWG #6 SOL	23	10mm ² STR [4.2]	8-10	----	.44 [11]	.41 [10]	.21 [5]	1.16 [29]	.22 [6]	.27 [7]	.08 [2]	.26 [7]
YA8CLBOX				8-10	----	.36 [9]	.21 [5]	1.16 [29]	.22 [6]	.09 [2]	.26 [7]		
YA8CLG4				1/4	M6	.44 [11]	.27 [7]	1.26 [32]	.25 [6]	.08 [2]	.33 [8]		
YA8CL1				5/16	----	.52 [13]	.33 [8]	1.38 [35]	.34 [9]	.06 [2]	.36 [9]		
YA8CL2				3/8	----	.58 [15]	.40 [10]	1.51 [38]	.41 [10]	.06 [2]	.42 [11]		
YA8CL3				1/2	M12	.71 [18]	.53 [13]	1.76 [45]	.53 [13]	.05 [1]	.55 [14]		
YA8CL4													

CONNECTOR SIZE	TOLERANCES					
	B	C	K DIA.	L	N	O.D.
-8C THRU -25	±.06	±.04	±.02	±.09	±.03	±.01
-26 THRU -34	±.08	±.04	±.02	±.12	±.03	±.01
-35 AND UP	±.09	±.06	±.02	±.15	±.06	±.01

TOLERANCE BLOCK

CATALOG NO.	COLOR CODE	DIE INFORMATION		MECHANICAL					HYDRAULIC					DIELESS (# CRIMPS)	WIRE STRIP LENGTH	
		DIE INDEX	TYPE	Y122CMR Y1MRTC	OUR840	MD6 MD7	MD6--R2 MD7-34R	Y500CT PATMD6 PAT600	Y34A Y34B Y34BH	Y35, Y39, Y750, PAT750	Y46, PAT46	Y45	Y48B			Y60BHU
YA8CL YA8CLBOX YA8CL1 YA8CL2 YA8CL3 YA8CL4 YA8CLG4	RED	49	RED DIE SET	RED (1)	X8CRT(1) W8CRT(1) W8CVT(1)	X8CRT(1) W8CVT(1) W8CRT(1)	X8CRT(1) W8CVT(1) W8CRT(1)	X8CRT(1) W8CVT(1) W8CRT(1)	-----	U8CRT(1)	U8CRT(1)	U8CRT(1)			RATCHET: Y8MRB-1(1)	7/16"
			NEST	-----	-----	-----	-----	-----	-----	-----	-----	-----	-----	MECHANICAL: MY29-3(1) MY29-11(1) MRC840(1)		
			INDENTOR	-----	-----	-----	-----	-----	-----	-----	-----	-----	-----	HYDRAULIC: Y81KFT (1) Y4PC834 (1)		

NOTES:

- MATERIAL: COPPER TUBING.
- FINISH: TIN PLATED.
"FOR ALTERNATIVE FINISH ADD ONE OF THE FOLLOWING SUFFIXES:
NICKEL = NK, LEAD = LD, BARE = BR, SILVER = SV"
- CATALOG # PT6515 ADAPTOR IS REQUIRED TO USE "U" DIES IN Y45 SERIES TOOLS.
- CATALOG # PUADP-1 ADAPTOR IS REQUIRED TO USE "U" DIES IN Y46 SERIES TOOLS.
- PERMANENT DIE IN TOOLING.
- DIMENSIONS IN BRACKETS [] ARE IN MILLIMETERS ROUNDED OFF TO THE NEAREST MILLIMETER, UNLESS OTHERWISE NOTED, AND ARE FOR REFERENCE ONLY.
- FOR USE BY CUSTOMERS THAT HAVE THIS HYPRESS™. NO NEW Y34A HYPRESS™ TOOLS ARE BEING PROCESSED. Y34A USES A--D NEST DIES ONLY.
- CONNECTORS ARE UL LISTED; UNDRILLED VERSIONS ARE NOT UL LISTED.
- CONNECTORS ARE CSA CERTIFIED; UNDRILLED VERSIONS ARE NOT CSA CERTIFIED.
- FOR UNDRILLED VERSIONS ADD SUFFIX "-U" TO END OF CATALOG NUMBER.
FOR UNDRILLED VERSIONS, USE D MIN. = N MAX. + Z MIN.
- "X", "W-RT", "W-VT", "U" & "L" DIE SETS ARE COLOR CODED. "A", "B" AND "C" DIES ARE NOT COLOR CODED. NESTS AND INDENTOR TYPE ARE NOT COLOR CODED.

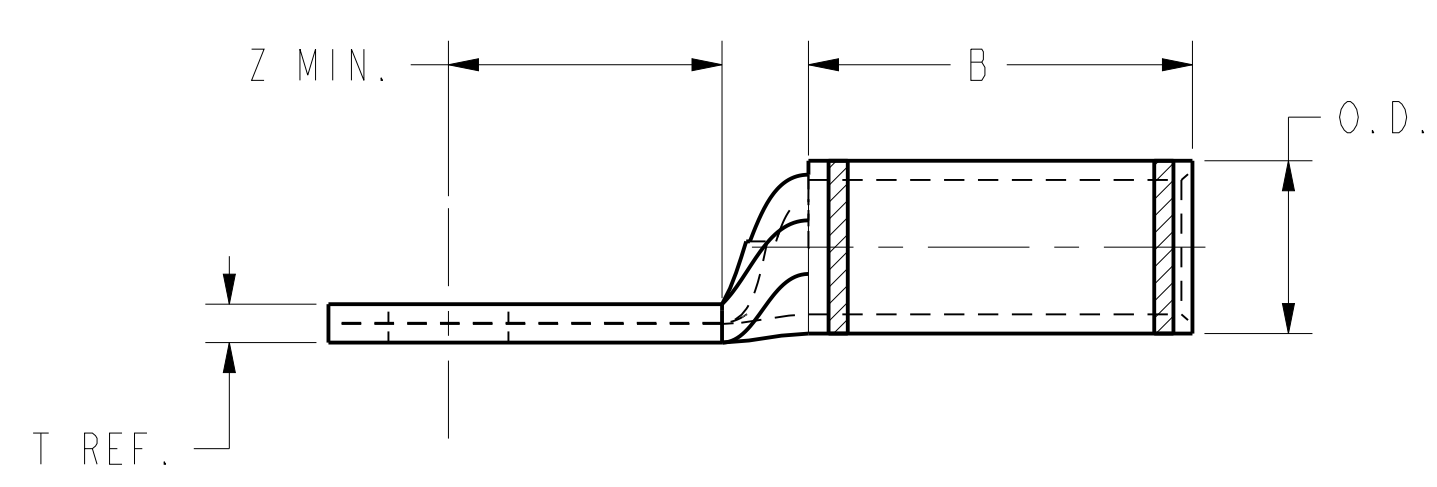
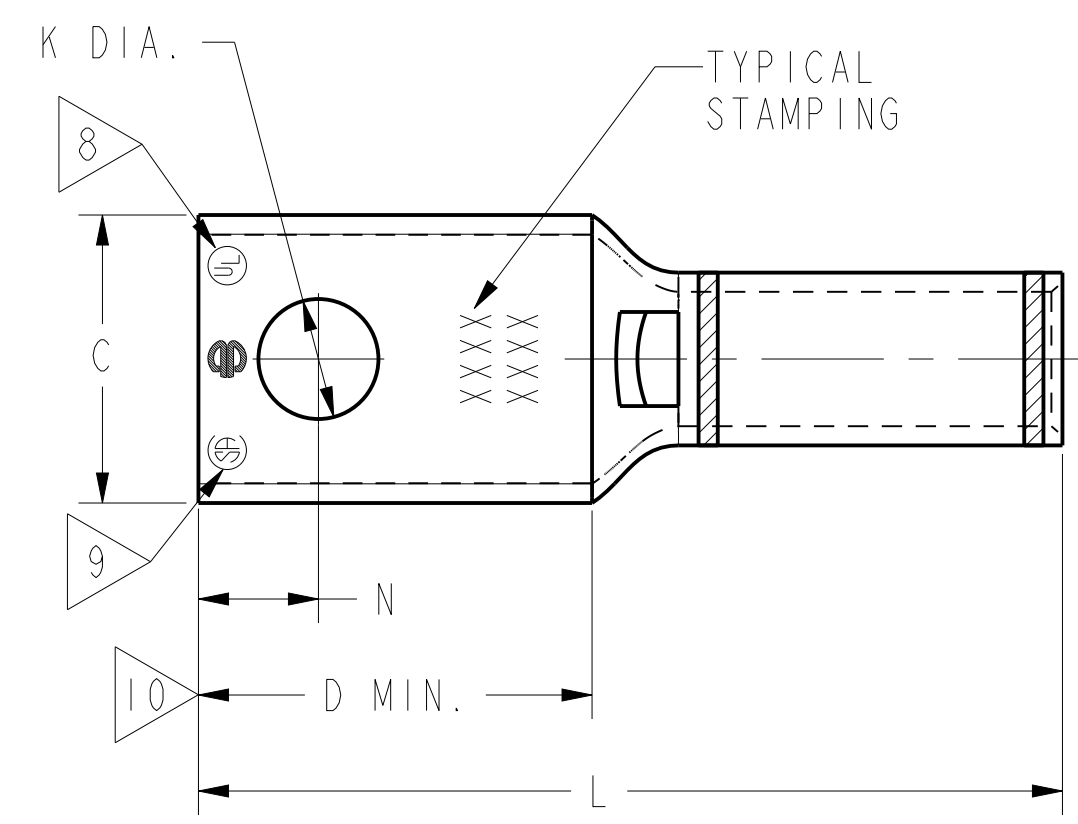

REFERENCE: SE209240

TO ORDER BURNDY® PRODUCTS CALL		HYLUG™ COPPER	
UNITED STATES 1-800-346-4175 (LONDONDERRY, NH)		ITEM NO: N/A	CAT. NO: YA-L, YA-L-TC-
CANADA: 1-800-361-6975 (QUEBEC) 1-800-387-6487 (ALL OTHER PROVINCES)		DRAWN BY: C. RACANO 11/29/76	CHECKER: CAR 12/10/76
FOR PRODUCT INFO: http://www.burndy.com		DSN APPVL: LB 12/10/76	MFG APPVL: N/A
		GA APPVL: C. ACKERMAN 9/30/94	MKT APPVL: T. NELSON 9/07/94
		PROD FAM: CM&R COMPRESSION	DRAWING NO: SD079848
		PROJECT #: --	SCALE: 1:1
		DOCUMENT TYPE: Sales	REV: P
		REL LEVEL: Released	SHEET 1 OF 17

REV: PE0200

REV	DATE	DESCRIPTION	ECO	BY	C.H.K.
P	2019-06-13 01:00:00 EDT	Y425L1BOX ADDED TO SHEET 00	51969	YR	SS

CATALOG NUMBER	STRANDED COPPER CONDUCTOR ACCOMMODATED			BOLT SIZE	METRIC BOLT SIZE	DIMENSIONS								
	CODE (AWG)	NAVY	METRIC SIZE (CLASS 2)			B	C	D MIN.	K DIA.	L	N	O.D.	T REF.	Z MIN.
YA6CL	#6 AWG SOL/STR	-----	-----	1/4	M6	.54 [14]	.45 [11]	----	.27 [7]	1.45 [37]	.31 [8]	.29 [7]	.08 [2]	.33 [8]
YA6CL1				8-10	----		.41 [10]	----	.20 [5]	1.27 [32]	.22 [6]		.09 [2]	.23 [6]
YA6CL1BOX				8-10	----		.36 [9]	----	.21 [5]	1.28 [33]	.22 [6]		.10 [3]	.26 [7]
YA6CL1G1				8-10	----		.52 [13]	----	.33 [8]	1.52 [39]	.34 [9]		.07 [2]	.36 [9]
YA6CL3				5/16	----									

CONNECTOR SIZE	TOLERANCES					
	B	C	K DIA.	L	N	O.D.
-8C THRU -25	±.06	±.04	±.02	±.09	±.03	±.01
-26 THRU -34	±.08	±.04	±.02	±.12	±.03	±.01
-35 AND UP	±.09	±.06	±.02	±.15	±.06	±.01

TOLERANCE BLOCK

CATALOG NO.	COLOR CODE	DIE INFORMATION		MECHANICAL RATCHET					HYDRAULIC					DIELESS (# OF CRIMPS)	WIRE STRIP LENGTH	
		DIE INDEX	TYPE	Y122CMR Y1MRTC	OUR840	MD6 MD7	MD6--R2 MD7-34R	Y500CT PATMD6 PAT600	Y34A Y34B Y34BH	Y35, Y39 Y750, PAT750	Y46 PAT46	Y45	Y48B			Y60BHU
YA6CL YA6CL1 YA6CL1BOX YA6CL1G1 YA6CL3	BLUE	7 374	BLUE DIE SET	BLUE (1)	X5CRT(1) X8CART(1)	X5CRT(1) W5CRT(1) W5CVT(1)	X5CRT(1) W5CRT(1) W5CVT(1)	X5CRT(1) W5CRT(1) W5CVT(1)	-----	U5CRT(1) U8CABT(1)	U5CRT(1) U8CABT(1)	U5CRT(1) U8CABT(1)	-----	-----	MECHANICAL: MY29-3 (1) MY29-11 (1) MRC840 (1)	9/16"
			NEST						A6CD(1) B6CD(1)	U6CD-1(1)	U6CD-1(1)	U6CD-1(1)			HYDRAULIC: Y644 (1) Y81KFT (1) Y4PC834 (1)	
			INDENTOR						Y34PR	Y34PR	Y34PR	Y34PR				

NOTES:

- MATERIAL: COPPER TUBING.
- FINISH: TIN PLATED.
"FOR ALTERNATIVE FINISH ADD ONE OF THE FOLLOWING SUFFIXES:
NICKEL = NK, LEAD = LD, BARE = BR, SILVER = SV"
- CATALOG # PT6515 ADAPTOR IS REQUIRED TO USE "U" DIES IN Y45 SERIES TOOLS.
- CATALOG # PUADP-1 ADAPTOR IS REQUIRED TO USE "U" DIES IN Y46 SERIES TOOLS.
- Y35P3 INDENTOR ADAPTOR REQUIRED FOR Y34PR INDENTOR.
- PERMANENT DIE IN TOOLING.
- DIMENSIONS IN BRACKETS [] ARE IN MILLIMETERS ROUNDED OFF TO THE NEAREST MILLIMETER, UNLESS OTHERWISE NOTED, AND ARE FOR REFERENCE ONLY.
- FOR USE BY CUSTOMERS THAT HAVE THIS HYPRESS™. NO NEW Y34A HYPRESS™ TOOLS ARE BEING PROCESSED. Y34A USES A--D NEST DIES ONLY.
- CONNECTORS ARE UL LISTED; UNDRILLED VERSIONS ARE NOT UL LISTED.
- CONNECTORS ARE CSA CERTIFIED; UNDRILLED VERSIONS ARE NOT CSA CERTIFIED.
- FOR UNDRILLED VERSIONS ADD SUFFIX "-U" TO END OF CATALOG NUMBER.
FOR UNDRILLED VERSIONS, USE D MIN. = N MAX. + Z MIN.
- "X", "W-RT", "W-VT", "U" & "L" DIE SETS ARE COLOR CODED. "A", "B" AND "C" DIES ARE NOT COLOR CODED. NESTS AND INDENTOR TYPE ARE NOT COLOR CODED.
- X8CABT & U8CABT DIES USED ON YA6C-- HYLUG™ NOT YA5C--HYLUG™.
- INSTALL 6 AWG SOL. WITH THESE TOOLS ONLY.

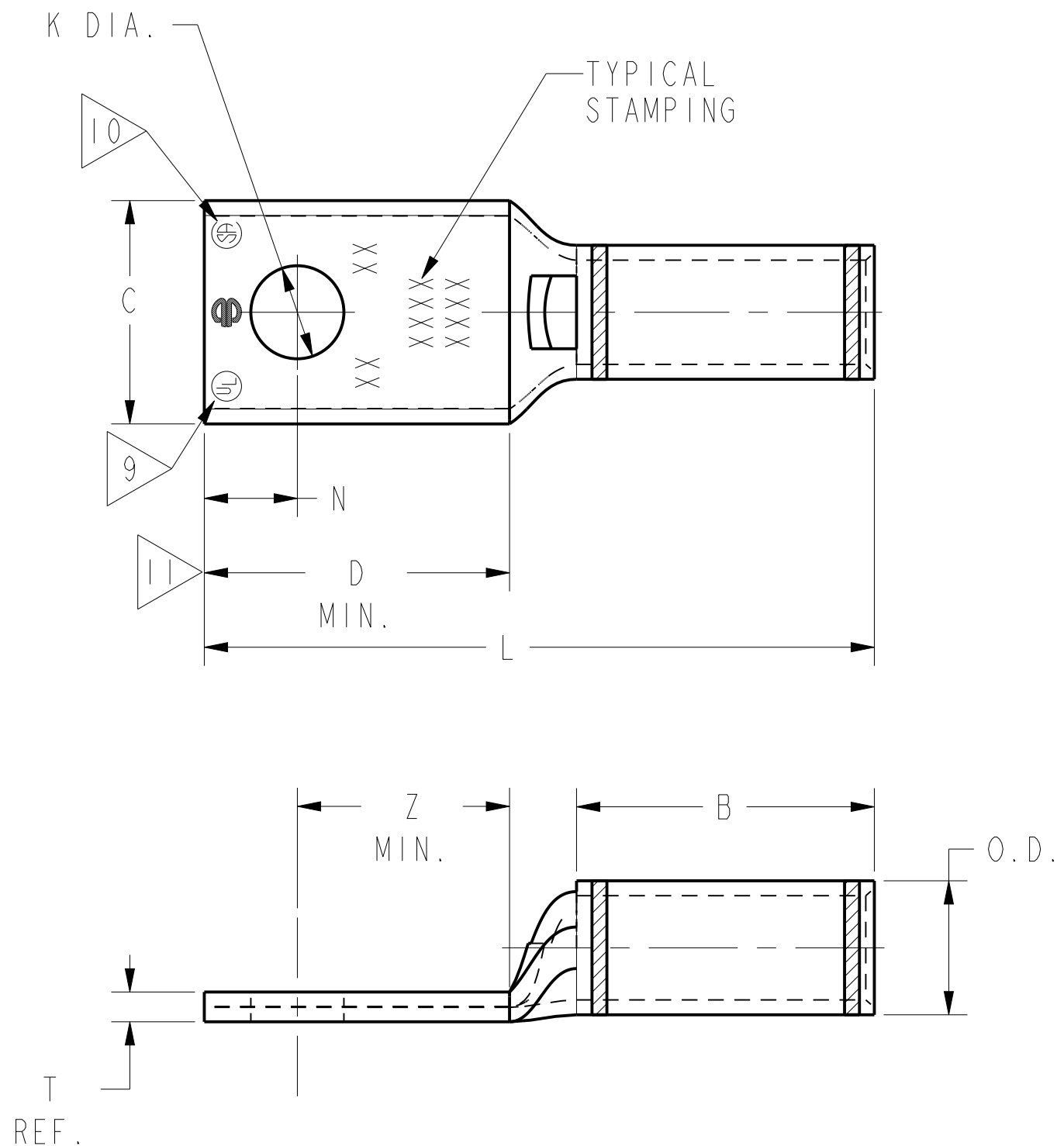

REFERENCE: SE209240

TO ORDER BURNDY® PRODUCTS CALL		HYLUG™ COPPER	
UNITED STATES 1-800-346-4175 (LONDONDERRY, NH)		ITEM NO: N/A	
CANADA: 1-800-361-6975 (QUEBEC) 1-800-387-6487 (ALL OTHER PROVINCES)		CAT. NO: YA-L, YA-L-TC-, YAV-TC-	
FOR PRODUCT INFO: http://www.burndy.com		DRAWN BY: C. RACCANO 06/16/1977	
		CHECKER: CAR 06/16/1977	
		DSN APPVL: LB 06/24/1977	
		MFG APPVL: N/A	
		QA APPVL: C. ACKERMAN 09/30/1994	
		MKT APPVL: T. NELSON 09/07/1994	
		PROD FAM: CM&R COMPRESSION	
		DRAWING NO	
		SD079848	
		SHEET 2 OF 17	
		SCALE: 1:1	
		PROJECT #: --	
		SIZE	
		D	
		DOCUMENT TYPE: Sales	
		REL LEVEL: Released	

REV: PEC200

REV	DATE	DESCRIPTION	ECO	BY	C'H'K.
P	2019-08-13 01:00:00 EDT	Y42L1001 ADDED TO SHEET 00	51969	YR	SS

CATALOG NUMBER	STRANDED COPPER CONDUCTOR ACCOMMODATED			BOLT SIZE	METRIC BOLT SIZE	DIMENSIONS								
	CODE (AWG)	NAVY	METRIC SIZE (CLASS 2)			B	C	D MIN.	K DIA.	L	N	O.D.	T REF.	Z MIN.
YA6CL4	#6 AWG SOL/STR	-----	-----	3/8	----	.54 [14]	.63 [16]	-----	.41 [10]	1.62 [41]	.41 [10]	.29 [7]	.06 [2]	.38 [10]
YA6CL4U				3/8	----	.54 [14]	.63 [16]	-----	-----	1.62 [41]	-----	.29 [7]	.06 [2]	.38 [10]
YA6CL6				1/2	M12	.54 [14]	.75 [19]	-----	.53 [13]	1.87 [48]	.53 [13]	.29 [7]	.12 [3]	.55 [14]
YA5CL	#5 AWG	30	-----	1/4	M6	.81 [21]	.44 [11]	-----	.27 [7]	1.65 [42]	.25 [6]	.30 [8]	.07 [2]	.33 [8]

CONNECTOR SIZE	TOLERANCES					
	B	C	K DIA.	L	N	O.D.
-8C THRU -25	±.06	±.04	±.02	±.09	±.03	±.01
-26 THRU -34	±.08	±.04	±.02	±.12	±.03	±.01
-35 AND UP	±.09	±.06	±.02	±.15	±.06	±.01

TOLERANCE BLOCK

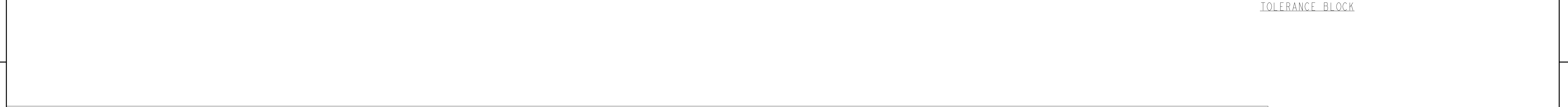

INSTALLATION TOOLING (# CRIMPS)																
CATALOG NUMBER	COLOR CODE	DIE INFORMATION		MECHANICAL					HYDRAULIC					DIELESS (# OF CRIMPS)	WIRE STRIP LENGTH	
		DIE INDEX	TYPE	Y122CMR Y1MRTC	OUR840	MD6 MD7	MD6--R2 MD7-34R	Y500CT PATMD6 PAT600	Y34A Y34B Y34BH	Y35, Y39, PAT750 Y750, PAT750	Y46 PAT46	Y45	Y48B			Y60BHU
YA6CL4	BLUE	7 374	BLUE DIE SET	BLUE (1)	X5CRT(1) X8CART(1)	X5CRT(1) W5CRT(1) W5CVT(1) X8CART(1)	X5CRT(1) W5CRT(1) W5CVT(1) X8CART(1)	X5CRT(1) W5CRT(1) W5CVT(1)	-----	U5CRT(1) U8CABT(1)	U5CRT(1) U8CABT(1)	U5CRT(1) U8CABT(1)	-----	-----	MECHANICAL: MY29-3 (1) MY29-11 (1) MRC840 (1)	9/16"
YA6CL6			NEST	-----	-----	-----	-----	-----	A6CD(1) B6CD(1)	U6CD-1(1)	U6CD-1(1)	U6CD-1(1)	-----	-----	HYDRAULIC: Y644 (1) Y81KFT (1) Y4PC834 (1)	
YA5CL			INDENTOR	-----	-----	-----	-----	-----	-----	Y34PR	Y34PR	Y34PR	Y34PR	-----	-----	

- NOTES:
- MATERIAL: COPPER TUBING.
 - FINISH: TIN PLATED.
"FOR ALTERNATIVE FINISH ADD ONE OF THE FOLLOWING SUFFIXES:
NICKEL = NK, LEAD = LD, BARE = BR, SILVER = SV"
 - CATALOG # PT6515 ADAPTOR IS REQUIRED TO USE "U" DIES IN Y45 SERIES TOOLS.
 - CATALOG # PUADP-1 ADAPTOR IS REQUIRED TO USE "U" DIES IN Y46 SERIES TOOLS.
 - Y35P3 INDENTOR ADAPTOR REQUIRED FOR Y34PR INDENTOR.
 - PERMANENT DIE IN TOOLING.
 - DIMENSIONS IN BRACKETS [] ARE IN MILLIMETERS ROUNDED OFF TO THE NEAREST MILLIMETER, UNLESS OTHERWISE NOTED, AND ARE FOR REFERENCE ONLY.
 - FOR USE BY CUSTOMERS THAT HAVE THIS HYPRESS™. NO NEW Y34A HYPRESS™ TOOLS ARE BEING PROCESSED. Y34A USES A--D NEST DIES ONLY.
 - CONNECTORS ARE UL LISTED; UNDRILLED VERSIONS ARE NOT UL LISTED.
 - CONNECTORS ARE CSA CERTIFIED. UNDRILLED VERSIONS ARE NOT CSA CERTIFIED.
 - FOR UNDRILLED VERSIONS ADD SUFFIX "-U" TO END OF CATALOG NUMBER. FOR UNDRILLED VERSIONS, USE D MIN. = N MAX. + Z MIN.
 - "X", "W-RT", "W-VT", "U" & "L" DIE SETS ARE COLOR CODED. "A", "B" AND "C" DIES ARE NOT COLOR CODED. NESTS AND INDENTOR TYPE ARE NOT COLOR CODED.
 - X8CABT & U8CABT DIES USED ON YA6C-- HYLUG™ NOT YA5C--HYLUG™
 - INSTALL 6 AWG SOL. WITH THESE TOOLS ONLY.

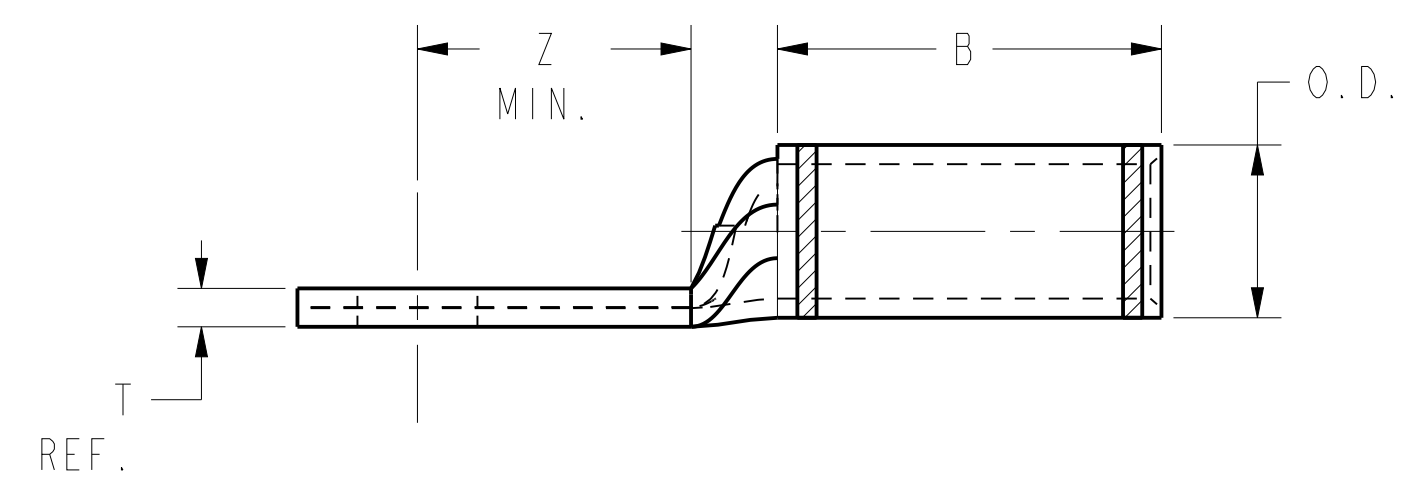
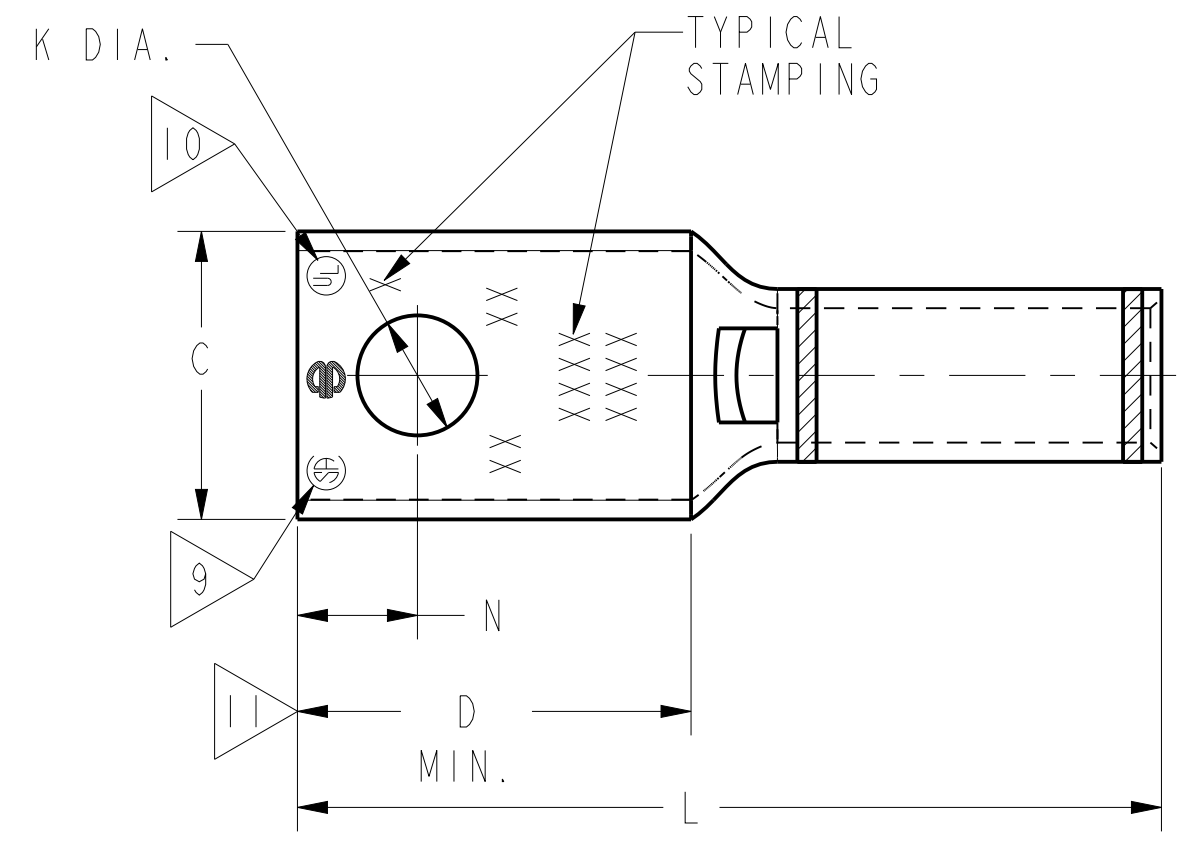

REFERENCE: SE209240

TO ORDER BURNDY® PRODUCTS CALL		HYLUG™ COPPER	
UNITED STATES 1-800-346-4175 (LONDONDERRY, NH)		ITEM NO: N/A	CAT. NO: YA-L, YA-L-TC-, YAV-TC-
CANADA: 1-800-361-6975 (QUEBEC) 1-800-387-6487 (ALL OTHER PROVINCES)		DRAWN BY: C. RACCANO 6/16/77	CHECKER: CAR 6/16/77
FOR PRODUCT INFO: http://www.burndy.com		DSN APPVL: LB 6/24/77	MFG APPVL: N/A N/A
		GA APPVL: C. ACKERMAN 9/30/94	MKT APPVL: T. NELSON 9/7/94
		PROD FAM: CM&R COMPRESSION	DRAWING NO: REV
		PROJECT #: --	SIZE: SD079848
		DOCUMENT TYPE: Sales	SHEET 3 OF 17
		REL LEVEL: Released	

REV: PEO200

REV	DATE	DESCRIPTION	ECO	BY	C.H.K.
P	2019-08-13 01:00:00 EDT	HYSLUG ADDED TO SHEET 4B	51969	YR	SS

CATALOG NUMBER	STRANDED COPPER CONDUCTOR ACCOMMODATED			BOLT SIZE	METRIC BOLT SIZE	DIMENSIONS								
	CODE (AWG)	NAVY	METRIC SIZE (CLASS 2)			B	C	D MIN.	K DIA.	L	N	O.D.	T REF.	Z MIN.
YA4CL1	#4 AWG	40	-----	8-10	M5	.81 [21]	.50 [13]	-----	.21 [5]	1.58 [40]	.25 [6]	.34 [9]	.09 [2]	.24 [6]
YA4CL1U				-----	-----	-----	.50 [13]	.52 [13]	-----	1.57 [40]	-----		.09 [2]	-----
YA4CL				1/4	M6	-----	.50 [13]	-----	.27 [7]	1.74 [44]	.31 [8]		.09 [2]	.33 [8]
YA4CLU				-----	-----	-----	.50 [13]	.61 [15]	-----	1.67 [42]	-----		.09 [2]	-----
YA4CL3				5/16	M8	-----	.50 [13]	-----	.34 [9]	1.79 [45]	.41 [10]		.09 [2]	.42 [11]
YA4CL3BOX							-----	-----	-----	-----	-----		-----	-----
YA4CL4				3/8	-----	-----	.58 [15]	-----	.40 [10]	1.92 [49]	.41 [10]		.08 [2]	.42 [11]
YA4CL4U							-----	-----	-----	.58 [15]	.86 [22]		-----	1.95 [50]
YA4CL5				7/16	-----	-----	.64 [16]	-----	.47 [12]	2.03 [52]	.46 [12]		.07 [2]	.48 [12]
YA4CL6							1/2	M12	-----	.81 [21]	.71 [18]		-----	.53 [13]

CONNECTOR SIZE	TOLERANCES					
	B	C	K DIA.	L	N	O.D.
-8C THRU -25	±.06	±.04	±.02	±.09	±.03	±.01
-26 THRU -34	±.08	±.04	±.02	±.12	±.03	±.01
-35 AND UP	±.09	±.06	±.02	±.15	±.06	±.01

TOLERANCE BLOCK

INSTALLATION TOOLING (# CRIMPS)																
CATALOG NUMBER	COLOR CODE	DIE INFORMATION		MECHANICAL				HYDRAULIC						DIELESS (# CRIMPS)	WIRE STRIP LENGTH	
		DIE INDEX	TYPE	Y122CMR Y1MRTC	OUR840	MD6 MD7	MD6--R2 MD7-34R	Y500CT PATMD6 PAT600	Y34A Y34B Y34BH	Y35, Y39 Y750, PAT750	Y46 PAT46	Y45	Y48B			Y60BHU
YA4CL1 YA4CL1U YA4CL YA4CLU YA4CL3 YA4CL3BOX YA4CL4 YA4CL4U YA4CL5 YA4CL6	GRAY	8 346	GRAY DIE SET	GRAY (2)	X4CRT(1)	X4CRT(1) W4CRT(1) W4CVT(1)	X4CRT(1) W4CRT(1) W4CVT(1)	X4CRT(1) W4CRT(1) W4CVT(1)	-----	U4CRT(1) U6CABT(1)	U4CRT(1) U6CABT(1)	U4CRT(1) U6CABT(1)	-----	-----	MECHANICAL: MY29-3 (1) MY29-11 (1) MRC840 (1)	7/8"
			NEST	-----	-----	-----	-----	-----	A4CD(1) B4CD(1)	U4CD-1(1)	U4CD-1(1)	U4CD-1(1)	-----	-----	HYDRAULIC: Y644 (1) Y81KFT (1) Y4PC834 (1)	
			INDENTOR	-----	-----	-----	-----	-----	Y34PR	Y34PR	Y34PR	Y34PR	-----	-----		

- NOTES:
- MATERIAL: COPPER TUBING.
 - FINISH: TIN PLATED.
"FOR ALTERNATIVE FINISH ADD ONE OF THE FOLLOWING SUFFIXES:
NICKEL = NK, LEAD = LD, BARE = BR, SILVER = SV"
 - CATALOG # PT6515 ADAPTOR IS REQUIRED TO USE "U" DIES IN Y45 SERIES TOOLS.
 - CATALOG # PUADP-1 ADAPTOR IS REQUIRED TO USE "U" DIES IN Y46 SERIES TOOLS.
 - Y35P3 INDENTOR ADAPTOR REQUIRED FOR Y34PR INDENTOR.
 - PERMANENT DIE IN TOOLING.
 - DIMENSIONS IN BRACKETS [] ARE IN MILLIMETERS ROUNDED OFF TO THE NEAREST MILLIMETER, UNLESS OTHERWISE NOTED, AND ARE FOR REFERENCE ONLY.
 - FOR USE BY CUSTOMERS THAT HAVE THIS HYPRESS™. NO NEW Y34A HYPRESS™ TOOLS ARE BEING PROCESSED. Y34A USES A--D NEST DIES ONLY.
 - CONNECTORS ARE UL LISTED; UNDRILLED VERSIONS ARE NOT UL LISTED.
 - CONNECTORS ARE CSA CERTIFIED. UNDRILLED VERSIONS ARE NOT CSA CERTIFIED.
 - FOR UNDRILLED VERSIONS ADD SUFFIX "-U" TO END OF CATALOG NUMBER.
FOR UNDRILLED VERSIONS, USE D MIN. = N MAX. + Z MIN.
 - "X", "W-RT", "W-VT", "U" & "L" DIE SETS ARE COLOR CODED. "A", "B" AND "C" DIES ARE NOT COLOR CODED. NESTS AND INDENTOR TYPE ARE NOT COLOR CODED.

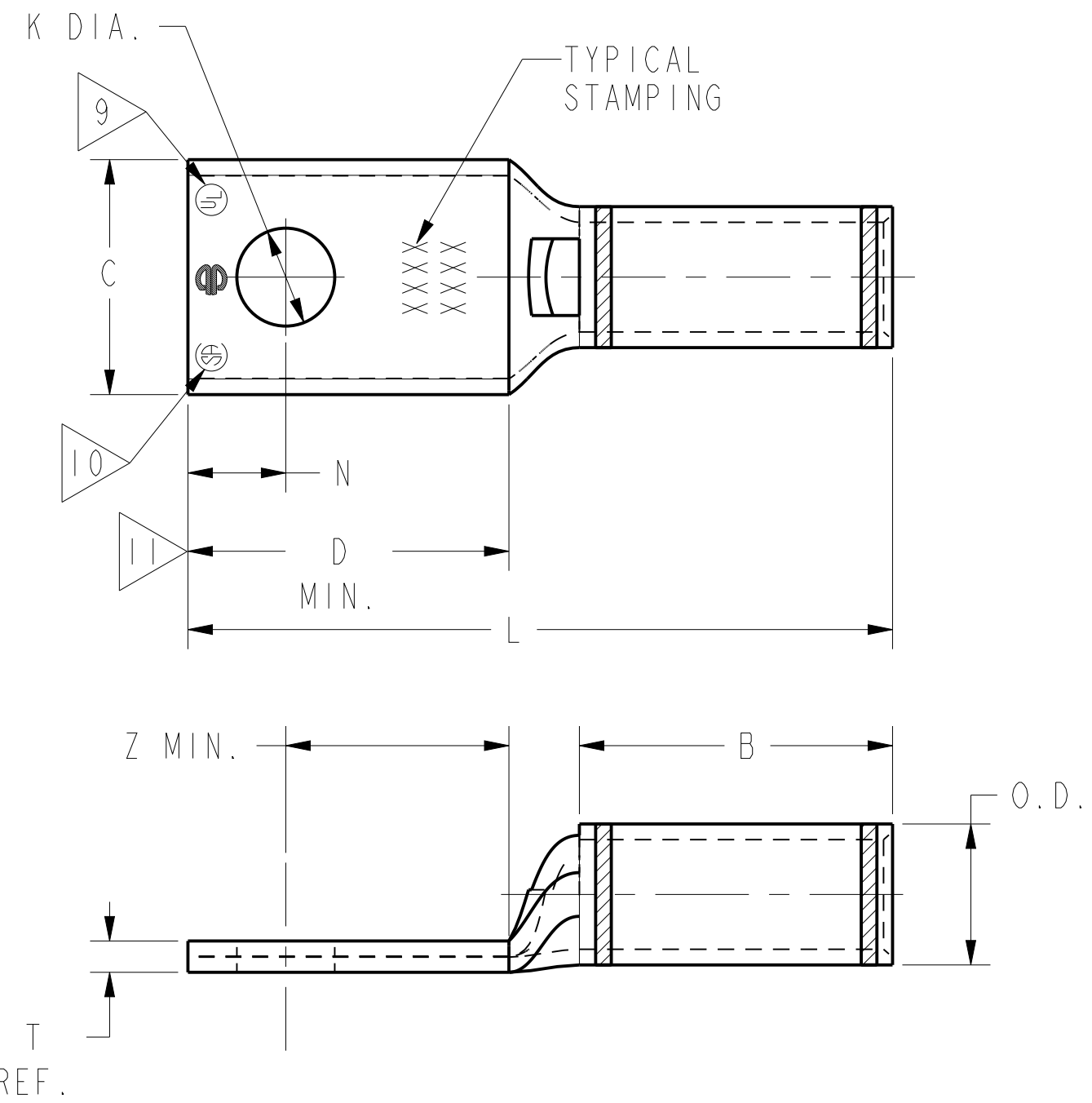

REFERENCE: SE209240

TO ORDER BURNDY® PRODUCTS CALL		HYLUG™ COPPER	
UNITED STATES 1-800-346-4175 (LONDONDERRY, NH)		ITEM NO: N/A	CAT. NO: YA4C-L - (TABLE)
CANADA: 1-800-361-6975 (QUEBEC) 1-800-387-6487 (ALL OTHER PROVINCES)		DRAWN BY: C. RACCANO 8/16/77	CHECKER: CAR 6/16/77
FOR PRODUCT INFO: http://www.burndy.com		DSN APPVL: LB 6/16/77	MFG APPVL: N/A N/A
		GA APPVL: C. ACKERMAN 9/30/94	MKT APPVL: T. NELSON 9/07/94
		PROD FAM: CM&R COMPRESSION	DRAWING NO: SD079848
		PROJECT #: --	SCALE: 1:1
		DOCUMENT TYPE: Sales	REV: P
		REL LEVEL: Released	SHEET 4 OF 17

REV: PEC200

REV	DATE	DESCRIPTION	ECO	BY	CHK.
P	2019-08-13 01:00:00 EDT	Y425/1008 ADDED TO SHEET 08	51969	YR	SS

CATALOG NUMBER	STRANDED COPPER CONDUCTOR ACCOMMODATED			BOLT SIZE	METRIC BOLT SIZE	DIMENSIONS							
	CODE (AWG)	NAVY	METRIC SIZE (CLASS 2)			B	C	K DIA.	L	N	O.D.	T REF.	Z MIN.
YA3CL	#3 AWG	50	25mm ² STR [6.6]	5/16	M8	.88 [22]	.55 [14]	.33 [8]	1.88 [48]	.34 [9]	.38 [10]	.09 [2]	.36 [9]
YA3CL4		60		3/8	M10		.58 [15]	.41 [10]	2.05 [52]	.41 [10]	.38 [10]	.08 [2]	.42 [11]
YA3CL6		50		1/2	M12		.73 [19]	.53 [13]	2.30 [58]	.53 [13]	.38 [10]	.07 [2]	.55 [14]
YA2CL2	#2 AWG	60	1/4	M6	.61 [15]		.27 [7]	1.88 [48]	.31 [8]	.42 [11]	.11 [3]	.33 [8]	
YA2CL2U		-----	---	---	.60 [15]		---	1.77 [45]	---	.42 [11]	.11 [3]	---	
YA2CL		-----	---	---	.61 [15]		.33 [8]	1.93 [49]	.34 [9]	.42 [11]	.11 [3]	.36 [9]	

CONNECTOR SIZE	TOLERANCES					
	B	C	K DIA.	L	N	O.D.
-8C THRU -25	±.06	±.04	±.02	±.09	±.03	±.01
-26 THRU -34	±.08	±.04	±.02	±.12	±.03	±.01
-35 AND UP	±.09	±.06	±.02	±.15	±.06	±.01

TOLERANCE BLOCK

INSTALLATION TOOLING (# CRIMPS)																
CATALOG NO.	COLOR CODE	DIE INFORMATION		MECHANICAL				HYDRAULIC						DIELESS (# CRIMPS)	WIRE STRIP LENGTH	
		DIE INDEX	TYPE	Y122CMR Y1MRTC	OUR840	MD6 MD7	MD6--R2 MD7-34R	Y500CT PATMD6 PAT600	Y34A Y34B Y34BH	Y35, Y39, Y750, PAT750	Y46 PAT46	Y45	Y48B			Y60BHU
YA3CL YA3CL4 YA3CL6	WHITE	9	WHITE DIE SET	WHITE (2)	W3CRT (1)	W3CRT (1)	W3CRT (1)	W3CRT (1)	-----	U3CRT(1)	U3CRT(1)	U3CRT(1)	---	---	MECHANICAL: MY29-3 (1) MY29-11(1)	15/16"
			NEST	-----	-----	-----	-----	-----	A3CD(1) B3CD(1)	U3CD-1(1)	U3CD-1(1)	U3CD-1(1)	↑	↑	HYDRAULIC: Y644 (1) Y81KFT (1) Y4PC834 (1)	
			INDENTOR	-----	-----	-----	-----	-----	Y34PR	Y34PR	Y34PR	Y34PR	↓	↓		
YA2CL2 YA2CL2U YA2CL	BROWN	10	BROWN DIE SET	BROWN(2)	X2CRT(1)	X2CRT(2) W2CRT(1) W2CVT(1)	X2CRT(2) W2CRT(1) W2CVT(1)	X2CRT(1) W2CRT(1) W2CVT(1)	-----	U2CRT(1)	U2CRT(1)	U2CRT(1)	↑	↑	MECHANICAL: MY29-3 (1) MY29-11(1) MRC840 (1)	15/16"
			NEST	-----	-----	-----	-----	-----	A2CD(1) B2CD(1)	U2CD-1(1)	U2CD-1(1)	U2CD-1(1)	↓	↓	HYDRAULIC: Y644 (1) Y81KFT (1) Y4PC834 (1)	
			INDENTOR	-----	-----	-----	-----	-----	Y34PR	Y34PR	Y34PR	Y34PR	---	---		

- NOTES:**
- MATERIAL: COPPER TUBING.
 - FINISH: TIN PLATED.
"FOR ALTERNATIVE FINISH ADD ONE OF THE FOLLOWING SUFFIXES:
NICKEL = NK, LEAD = LD, BARE = BR, SILVER = SV"
 - CATALOG # PT6515 ADAPTOR IS REQUIRED TO USE "U" DIES IN Y45 SERIES TOOLS.
 - CATALOG # PUADP-1 ADAPTOR IS REQUIRED TO USE "U" DIES IN Y46 SERIES TOOLS.
 - Y35P3 INDENTOR ADAPTOR REQUIRED FOR Y34PR INDENTOR.
 - PERMANENT DIE IN TOOLING.
 - DIMENSIONS IN BRACKETS [] ARE IN MILLIMETERS ROUNDED OFF TO THE NEAREST MILLIMETER, UNLESS OTHERWISE NOTED, AND ARE FOR REFERENCE ONLY.
 - FOR USE BY CUSTOMERS THAT HAVE THIS HYPRESS™. NO NEW Y34A HYPRESS™ TOOLS ARE BEING PROCESSED. Y34A USES A--D NEST DIES ONLY.
 - CONNECTORS ARE UL LISTED; UNDRILLED VERSIONS ARE NOT UL LISTED.
 - CONNECTORS ARE CSA CERTIFIED. UNDRILLED VERSIONS ARE NOT CSA CERTIFIED.
 - FOR UNDRILLED VERSIONS ADD SUFFIX "-U" TO END OF CATALOG NUMBER.
FOR UNDRILLED VERSIONS, USE D MIN. = N MAX. + Z MIN.
 - "X", "W-RT", "W-VT", "U" & "L" DIE SETS ARE COLOR CODED. "A", "B" AND "C" DIES ARE NOT COLOR CODED. NESTS AND INDENTOR TYPE ARE NOT COLOR CODED.

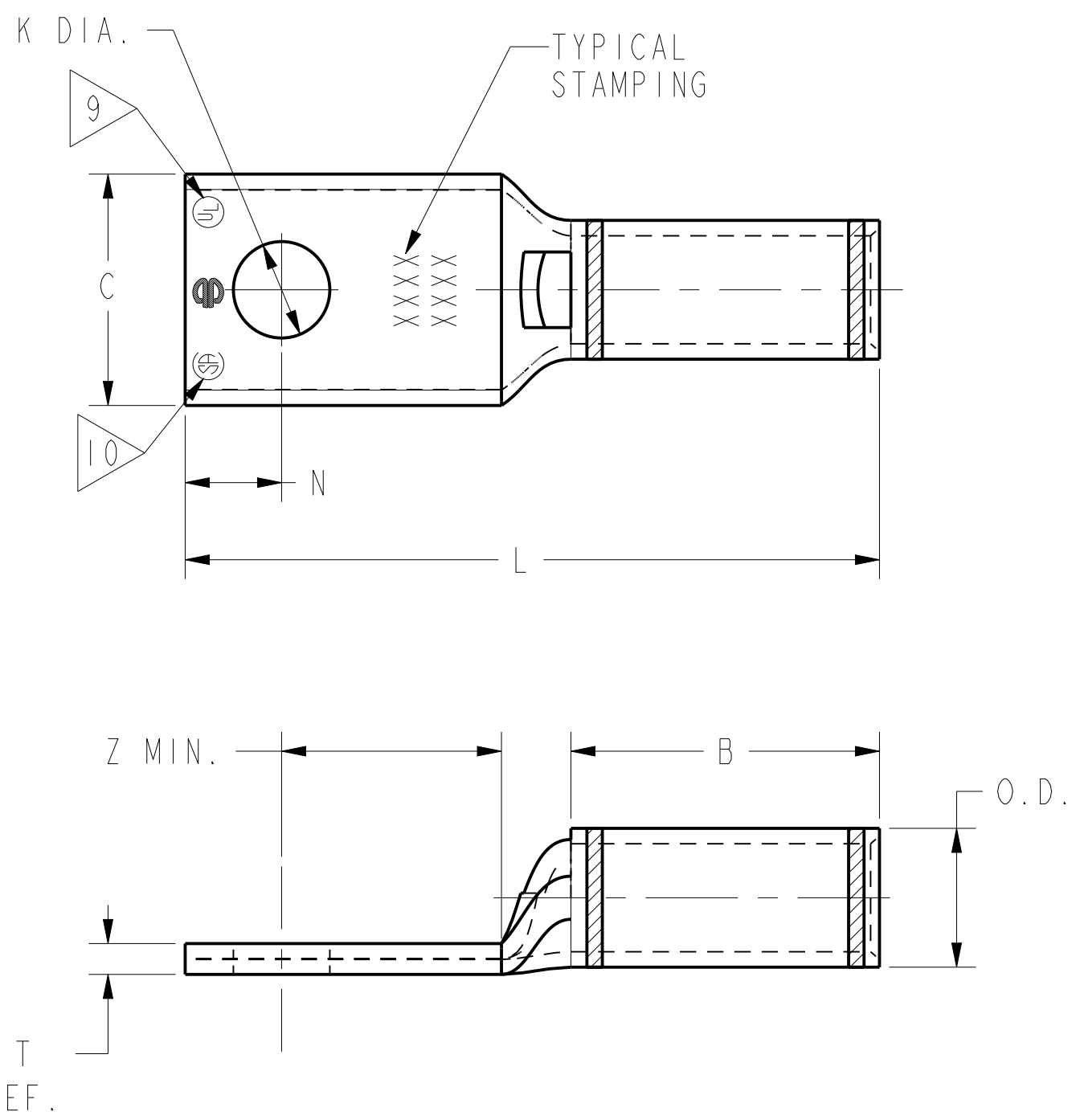

REFERENCE: SE209240

TO ORDER BURNDY® PRODUCTS CALL		HYLUG™ COPPER	
UNITED STATES 1-800-346-4175 (LONDONDERRY, NH)		ITEM NO: N/A	CAT. NO: YA-C-L- (TABLE)
CANADA: 1-800-361-6975 (QUEBEC) 1-800-387-6487 (ALL OTHER PROVINCES)		DRAWN BY: C. RACCANO 6/16/77	CHECKER: CAR 6/16/77
FOR PRODUCT INFO: http://www.burndy.com		DSN APPVL: LB 6/24/77	MFG APPVL: N/A N/A
		QA APPVL: C. ACKERMAN 9/30/94	MKT APPVL: T. NELSON 9/07/94
		PROD FAM: CM&R COMPRESSION	DRAWING NO: SD079848
		PROJECT #: --	SCALE: 1:1
		DOCUMENT TYPE: Sales	REV: P
		REL LEVEL: Released	SHEET 5 OF 17

REV: PEO200

REV	DATE	DESCRIPTION	ECO	BY	C.H.K.
P	12/21/2016 00:00:00 AM	Y425L/100H ADDED TO SHEET 6B	45555	YR	SS

CATALOG NUMBER	STRANDED COPPER CONDUCTOR ACCOMMODATED			BOLT SIZE	METRIC BOLT SIZE	DIMENSIONS								
	CODE (AWG)	NAVY	METRIC SIZE (CLASS 2)			B	C	D MIN.	K DIA.	L	N	O.D.	T REF.	Z MIN.
YA2CLU	#2 AWG	60	-----	-----	-----	.88 [22]	.60 [15]	.73 [18]	-----	1.90 [48]	-----	.42 [11]	.11 [3]	-----
YA2CL4				3/8	-----	.61 [15]	-----	.40 [10]	2.06 [52]	.41 [10]	.42 [11]	.11 [3]	.42 [11]	
YA2CL4BOX				-----	-----	.60 [15]	.86 [22]	-----	2.02 [51]	-----	.11 [3]	-----	.11 [3]	-----
YA2CL4U				-----	-----	.73 [19]	-----	.53 [13]	2.32 [59]	.53 [13]	.09 [2]	.55 [14]		
YA2CL6				1/2	M/12	.88 [22]	.73 [19]	-----	.53 [13]	2.32 [59]	.53 [13]	.09 [2]	.55 [14]	

CONNECTOR SIZE	TOLERANCES					
	B	C	K DIA.	L	N	O.D.
-8C THRU -25	±.06	±.04	±.02	±.09	±.03	±.01
-26 THRU -34	±.08	±.04	±.02	±.12	±.03	±.01
-35 AND UP	±.09	±.06	±.02	±.15	±.06	±.01

TOLERANCE BLOCK

CATALOG NO.	COLOR CODE	DIE INFORMATION		MECHANICAL RATCHET					HYDRAULIC					DIELESS (# CRIMPS)	WIRE STRIP LENGTH	
		DIE INDEX	TYPE	Y122CMR Y1MRTC	OUR840	MD6 MD7	MD6--R2 MD7-34R	PATMD6 PAT600	Y34A Y34B Y34BH	Y35, Y39 Y750, PAT750	Y46 PAT46	Y45	Y48B			Y60BHU
YA2CLU YA2CL4 YA2CL4BOX YA2CL4U YA2CL6	BROWN	10	BROWN DIE SET	BROWN (2)	X2CRT(1)	X2CRT(1) W2CRT(1) W2CVT(1)	X2CRT(1) W2CRT(1) W2CVT(1)	X2CRT(1) W2CRT(1) W2CVT(1)	-----	U2CRT(1)	U2CRT(1)	U2CRT(1)	-----	-----	MECHANICAL MY29-3(1) MY29-11(1) MRC840 (1)	15/16"
			NEST	-----	-----	-----	-----	-----	A2CD(1) B2CD(1)	U2CD-1(1)	U2CD-1(1)	U2CD-1(1)	-----	HYDRAULIC: Y644 (1) Y81KFT (1) Y4PC834 (1)		
			INDENTOR	-----	-----	-----	-----	-----	Y34PR	Y34PR	Y34PR	Y34PR	-----			

NOTES:

- MATERIAL: COPPER TUBING.
- FINISH: TIN PLATED.
"FOR ALTERNATIVE FINISH ADD ONE OF THE FOLLOWING SUFFIXES:
NICKEL = NK, LEAD = LD, BARE = BR, SILVER = SV"
- CATALOG # PT6515 ADAPTOR IS REQUIRED TO USE "U" DIES IN Y45 SERIES TOOLS.
- CATALOG # PUADP-1 ADAPTOR IS REQUIRED TO USE "U" DIES IN Y46 SERIES TOOLS.
- Y35P3 INDENTOR ADAPTOR REQUIRED FOR Y34PR INDENTOR.
- PERMANENT DIE IN TOOLING.
- DIMENSIONS IN BRACKETS [] ARE IN MILLIMETERS ROUNDED OFF TO THE NEAREST MILLIMETER, UNLESS OTHERWISE NOTED, AND ARE FOR REFERENCE ONLY.
- FOR USE BY CUSTOMERS THAT HAVE THIS HYPRESS™. NO NEW Y34A HYPRESS™ TOOLS ARE BEING PROCESSED. Y34A USES A--D NEST DIES ONLY.
- CONNECTORS ARE UL LISTED; UNDRILLED VERSIONS ARE NOT UL LISTED.
- CONNECTORS ARE CSA CERTIFIED. UNDRILLED VERSIONS ARE NOT CSA CERTIFIED.
- FOR UNDRILLED VERSIONS ADD SUFFIX "-U" TO END OF CATALOG NUMBER.
FOR UNDRILLED VERSIONS, USE D MIN. = N MAX. + Z MIN.
- "X", "W-RT", "W-VT", "U" & "L" DIE SETS ARE COLOR CODED. "A", "B" AND "C" DIES ARE NOT COLOR CODED. NESTS AND INDENTOR TYPE ARE NOT COLOR CODED.

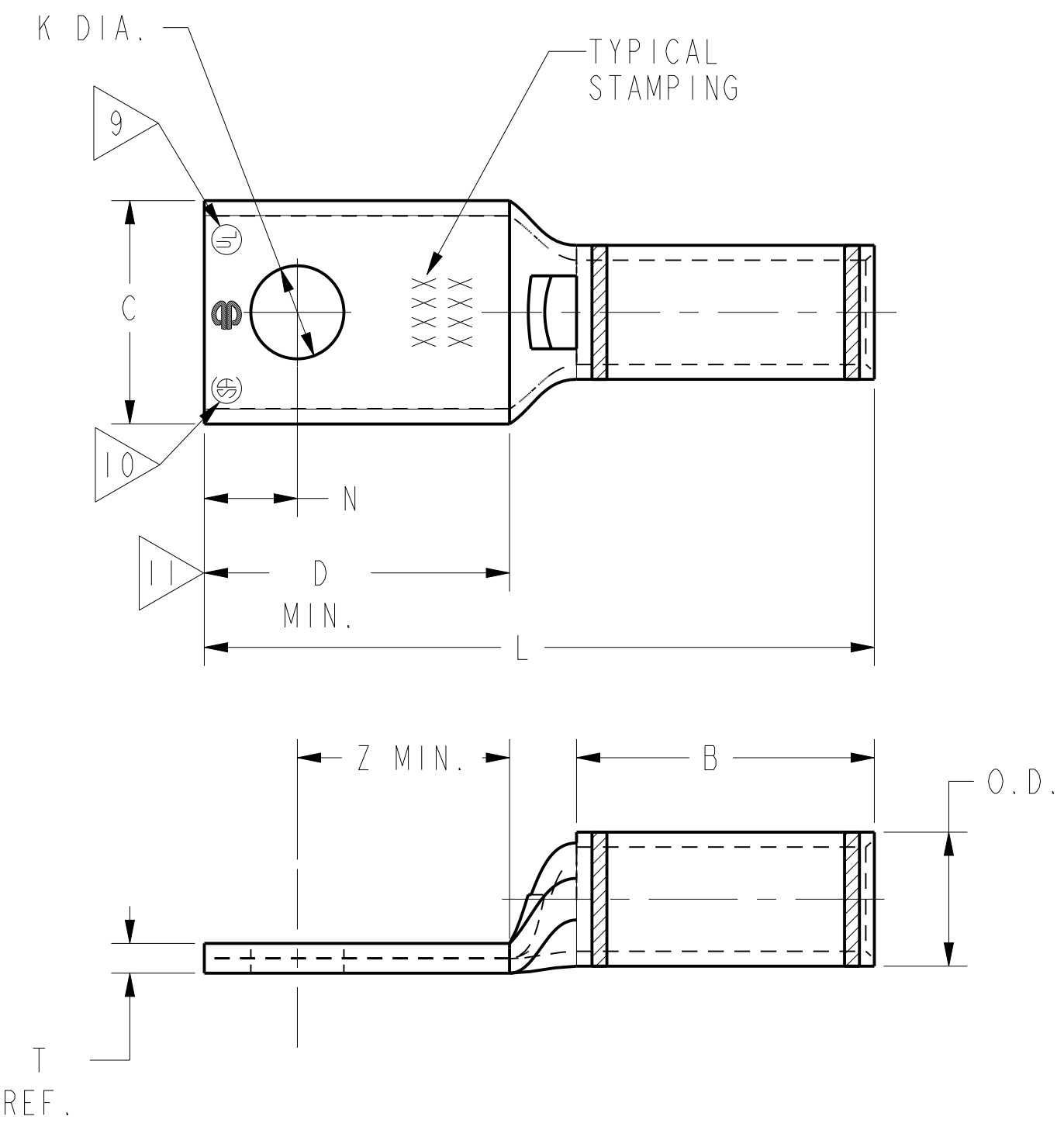

REFERENCE: SE209240
SUPERSEDES: SA79848 (SHT. 6)

TO ORDER BURNDY® PRODUCTS CALL		COPPER HYLUG™	
UNITED STATES 1-800-346-4175 (LONDONDERRY, NH)		ITEM NO: N/A	CAT. NO: YA-L, YA-L-TC-
CANADA: 1-800-387-6487 (ALL OTHER PROVINCES)		DRAWN BY: C.RACANO 6/16/77	CHECKER: CAR 6/16/77
FOR PRODUCT INFO: http://www.burndy.com		DSN APPVL: LB 6/24/77	MFG APPVL: N/A N/A
		QA APPVL: C.ACKERMAN 9/30/94	MKT APPVL: T.NELSON 9/7/94
		PROD FAM: CM&R COMPRESSION	DRAWING NO: SD079848
		PROJECT #: --	SCALE: 1:1
		DOCUMENT TYPE: Sales	REV: P
		REL LEVEL: Released	SHEET 6 OF 17

REV: PFC0200

REV	DATE	DESCRIPTION	ECO	BY	C.H.K.
P	2019-08-13 01:00:00 EDT	Y425/1008 ADDED TO SHEET 08	51969	YR	SS

CATALOG NUMBER	STRANDED COPPER CONDUCTOR ACCOMMODATED			BOLT SIZE	METRIC BOLT SIZE	DIMENSIONS							
	CODE (AWG)	NAVY	METRIC SIZE (CLASS 2)			B	C	K DIA.	L	N	O.D.	T REF.	Z MIN.
YAICL2	#1 AWG	75	-----	1/4	M6	.88 [22]	.68 [17]	.27 [7]	1.81 [46]	.25 [6]	.46 [12]	.10 [3]	.33 [8]
YAICL				5/16	----	.68 [17]	.33 [8]	1.94 [49]	.34 [9]	.10 [3]	.36 [9]		
YAICL4				3/8	----	.68 [17]	.40 [10]	2.06 [52]	.41 [10]	.10 [3]	.42 [11]		
YAICL6				1/2	M12	.88 [22]	.73 [19]	.53 [13]	2.37 [60]	.53 [13]	.46 [12]	.09 [2]	.55 [14]

CONNECTOR SIZE	TOLERANCES					
	B	C	K DIA.	L	N	O.D.
-8C THRU -25	±.06	±.04	±.02	±.09	±.03	±.01
-26 THRU -34	±.08	±.04	±.02	±.12	±.03	±.01
-35 AND UP	±.09	±.06	±.02	±.15	±.06	±.01

TOLERANCE BLOCK

CATALOG NO.	COLOR CODE	DIE INFORMATION		MECHANICAL RATCHET				HYDRAULIC				DIELESS (# CRIMPS)	WIRE STRIP LENGTH			
		DIE INDEX	TYPE	YIMRTC	OUR840	MD6 MD7	MD6--R2 MD7-34R	Y500CT PATMD6 PAT600	Y34A Y34B Y34BH	Y35, Y39 Y750, PAT750	Y46 PAT46			Y45	Y48B	Y60BHU
YAICL2 YAICL YAICL4 YAICL6	GREEN	11 375	GREEN DIE SET NEST INDENTOR	GREEN (2)	XICRT-1(1)	XICRT-1(1) WICRT-1(1) WICVT(1)	XICRT-1(1) WICRT-1(1) WICVT(1)	XICRT-1(1) WICRT-1(1) WICVT(1)	-----	UICRT-1 (1) U4CABT (1)	UICRT-1 (1) U4CABT (1)	UICRT-1 (1) U4CABT (1)	-----	-----	MECHANICAL MY29-3(1) MY29-11(1) MRC840 (1) HYDRAULIC: Y644 (1) Y81KFT (1) Y4PC834 (1)	15/16"
									Y34PR	Y34PR	Y34PR	Y34PR				

INSTALLATION TOOLING (# CRIMPS)

- NOTES:
- MATERIAL: COPPER TUBING.
 - FINISH: TIN PLATED.
"FOR ALTERNATIVE FINISH ADD ONE OF THE FOLLOWING SUFFIXES:
NICKEL = NK, LEAD = LD, BARE = BR, SILVER = SV"
 - CATALOG # PT6515 ADAPTOR IS REQUIRED TO USE "U" DIES IN Y45 SERIES TOOLS.
 - CATALOG # PUADP-1 ADAPTOR IS REQUIRED TO USE "U" DIES IN Y46 SERIES TOOLS.
 - Y35P3 INDENTOR ADAPTOR REQUIRED FOR Y34PR INDENTOR.
 - PERMANENT DIE IN TOOLING.
 - DIMENSIONS IN BRACKETS [] ARE IN MILLIMETERS ROUNDED OFF TO THE NEAREST MILLIMETER, UNLESS OTHERWISE NOTED, AND ARE FOR REFERENCE ONLY.
 - FOR USE BY CUSTOMERS THAT HAVE THIS HYPRESS™. NO NEW Y34A HYPRESS™ TOOLS ARE BEING PROCESSED. Y34A USES A--D NEST DIES ONLY.
 - CONNECTORS ARE UL LISTED; UNDRILLED VERSIONS ARE NOT UL LISTED.
 - CONNECTORS ARE CSA CERTIFIED; UNDRILLED VERSIONS ARE NOT CSA CERTIFIED.
 - FOR UNDRILLED VERSIONS ADD SUFFIX "-U" TO END OF CATALOG NUMBER.
FOR UNDRILLED VERSIONS, USE D MIN. = N MAX. + Z MIN.
 - "X", "W-RT", "W-VT", "U" & "L" DIE SETS ARE COLOR CODED. "A", "B" AND "C" DIES ARE NOT COLOR CODED. NESTS AND INDENTOR TYPE ARE NOT COLOR CODED.

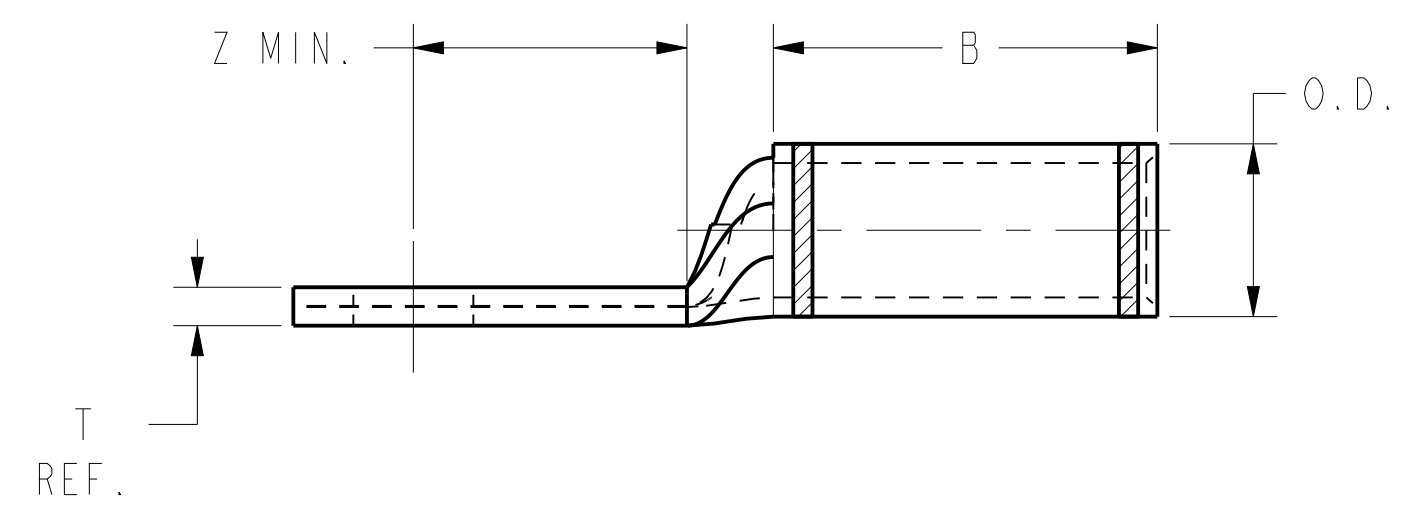
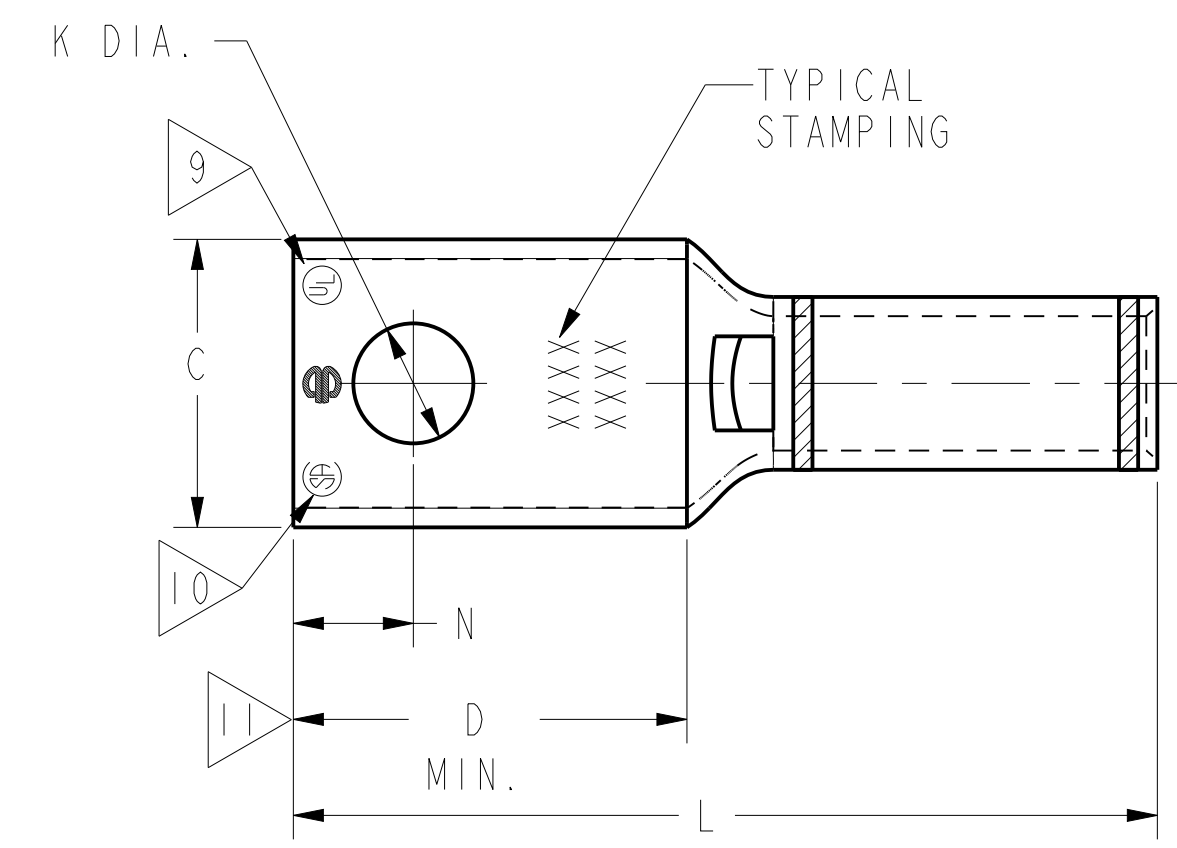

REFERENCE: SE209240

TO ORDER BURNDY® PRODUCTS CALL		COPPER HYLUG™	
UNITED STATES 1-800-346-4175 (LONDONDERRY, NH)		ITEM NO: N/A	CAT. NO: YA-L, YA-L-TC-, YAV-TC-
CANADA: 1-800-361-6975 (QUEBEC) 1-800-387-6487 (ALL OTHER PROVINCES)		DRAWN BY: J.MICHAUD 8/9/94	CHECKER: D.FILLION 10/3/94
FOR PRODUCT INFO: http://www.burndy.com		DSN APPVL: C.PALAGI 8/10/94	MFG APPVL: N/A N/A
		QA APPVL: C.ACKERMAN 9/30/94	MKT APPVL: T.NELSON 9/7/94
		PROD FAM: CM&R COMPRESSION	DRAWING NO: SD079848
		PROJECT #: FPN10004715	SIZE: D
		DOCUMENT TYPE: Sales	SHEET 7 OF 17
		REL LEVEL: Released	REV: P

REV: PEC200

REV	DATE	DESCRIPTION	ECO	BY	C.H.K.
P	2019-08-13 01:00:00 EDT	YA25L1BOX ADDED TO SHEET 8B	51969	YR	SS

CATALOG NUMBER	STRANDED COPPER CONDUCTOR ACCOMMODATED			BOLT SIZE	METRIC BOLT SIZE	DIMENSIONS							
	CODE (AWG)	NAVY	METRIC SIZE (CLASS 2)			B	C	K DIA.	L	N	O.D.	T REF.	Z MIN.
YA25L1BOX	#1/0 AWG	100	-----	8-10	M5	.88 [22]	.75 [19]	.21 [5]	1.84 [47]	.25 [6]	.51 [13]	.12 [13]	.33 [8]
YA25L2				1/4	M6	.27 [7]	1.84 [47]	.25 [6]	.51 [13]	.12 [13]	.33 [8]		
YA25L				5/16	M8	.33 [8]	1.96 [50]	.34 [9]					
YA25L4				3/8	M10	.41 [10]	2.09 [53]	.41 [10]					
YA25L6 YA25L6UNPL				1/2	M12	.53 [13]	2.34 [59]	.53 [13]					

CONNECTOR SIZE	TOLERANCES					
	B	C	K DIA.	L	N	O.D.
-8C THRU -25	±.06	±.04	±.02	±.09	±.03	±.01
-26 THRU -34	±.08	±.04	±.02	±.12	±.03	±.01
-35 AND UP	±.09	±.06	±.02	±.15	±.06	±.01

TOLERANCE BLOCK

INSTALLATION TOOLING (# CRIMPS)																
CATALOG NO.	COLOR CODE	DIE INFORMATION		MECHANICAL					HYDRAULIC					DIELESS (# CRIMPS)	WIRE STRIP LENGTH	
		DIE INDEX	TYPE	Y1MRTC	OUR840	MD6 MD7	MD6--R2 MD7-34R	Y500CT PATMD6 PAT600	Y34A Y34B Y34BH	Y35, Y39, Y750, BAT750 PAT750	Y46 PAT46	Y45	Y48B			Y60BHU
YA25L1BOX	PINK	12 348	PINK DIE SET	-----	X25CRT(2)	X25RT(2) W25RT(2) W25VT(2)	X25RT(2) W25RT(2) W25VT(2)	X25RT(2) W25RT(2) W25VT(2)	A25R(1)	U25RT(1) U2CABT(1)	U25RT(1) U2CABT(1)	U25RT(1) U2CABT(1)	-----	-----	MECHANICAL MY29-3(1) MY29-11(1) MRC840 (2) HYDRAULIC: Y644 (1) Y81KFT (1) Y4PC834 (1)	15/16"
YA25L2				NEST	-----	-----	-----	-----	A25D(1) B25D(1)	U25D-1(1)	U25D-1(1)	U25D-1(1)				
YA25L			-----		-----	-----	-----	Y34PR	Y34PR	Y34PR	Y34PR					
YA25L4			-----		-----	-----	-----	-----	-----	-----	-----	-----				
YA25L6 YA25L6UNPL			INDENTOR	-----	-----	-----	-----	-----	-----	-----	-----	-----				

NOTES:

- MATERIAL: COPPER TUBING.
- FINISH: TIN PLATED.
"FOR ALTERNATIVE FINISH ADD ONE OF THE FOLLOWING SUFFIXES:
NICKEL = NK, LEAD = LD, BARE = BR, SILVER = SV"
- CATALOG # PT6515 ADAPTOR IS REQUIRED TO USE "U" DIES IN Y45 SERIES TOOLS.
- CATALOG # PUADP-1 ADAPTOR IS REQUIRED TO USE "U" DIES IN Y46 SERIES TOOLS.
- Y35P3 INDENTOR ADAPTOR REQUIRED FOR Y34PR INDENTOR.
- PERMANENT DIE IN TOOLING.
- DIMENSIONS IN BRACKETS [] ARE IN MILLIMETERS ROUNDED OFF TO THE NEAREST MILLIMETER, UNLESS OTHERWISE NOTED, AND ARE FOR REFERENCE ONLY.
- FOR USE BY CUSTOMERS THAT HAVE THIS HYPRESS™. NO NEW Y34A HYPRESS™ TOOLS ARE BEING PROCESSED. Y34A USES A--D NEST DIES ONLY.
- CONNECTORS ARE UL LISTED; UNDRILLED VERSIONS ARE NOT UL LISTED.
- CONNECTORS ARE CSA CERTIFIED. UNDRILLED VERSIONS ARE NOT CSA CERTIFIED.
- FOR UNDRILLED VERSIONS ADD SUFFIX "-U" TO END OF CATALOG NUMBER.
FOR UNDRILLED VERSIONS, USE D MIN. = N MAX. + Z MIN.
- "X", "W-RT", "W-VT", "U" & "L" DIE SETS ARE COLOR CODED. "A", "B" AND "C" DIES ARE NOT COLOR CODED. NESTS AND INDENTOR TYPE ARE NOT COLOR CODED.
- ADD SUFFIX "UNPL" FOR UNPLATED CONNECTORS WITH NO BARREL MARKINGS.

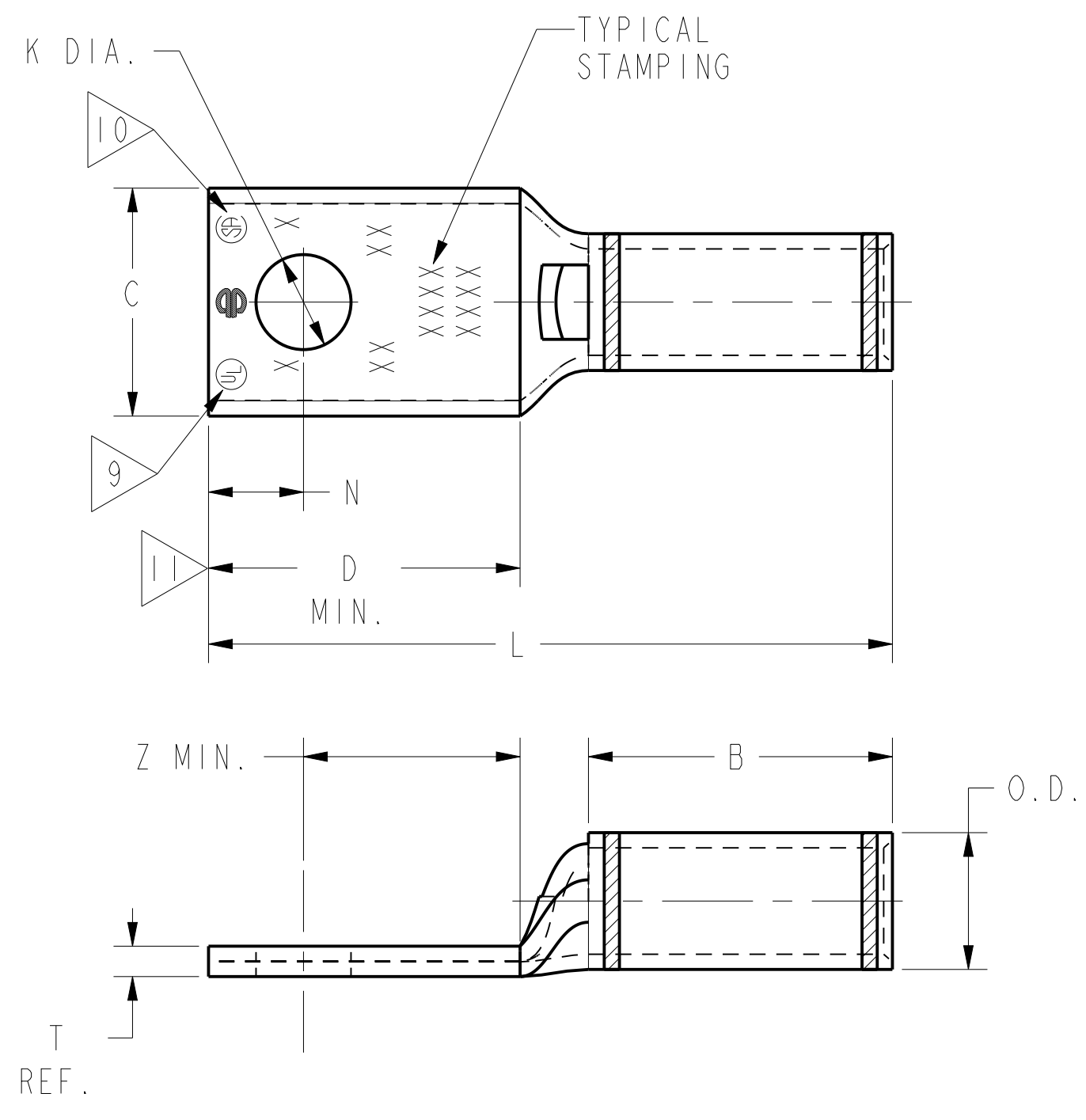

REFERENCE: SE209240

TO ORDER BURNDY® PRODUCTS CALL		COPPER HYLUG™	
UNITED STATES 1-800-346-4175 (LONDONDERRY, NH)		ITEM NO: N/A	CAT. NO: YA-L, YA-L-TC-
CANADA: 1-800-361-6975 (QUEBEC) 1-800-387-6487 (ALL OTHER PROVINCES)		DRAWN BY: R.NARESH 4/06/05	CHECKER: K.BABU 4/06/05
FOR PRODUCT INFO: http://www.burndy.com		DSN APPVL: --	MFG APPVL: --
		QA APPVL: --	MKT APPVL: --
		PROD FAM: CM&R COMPRESSION	DRAWING NO: SD079848
		PROJECT #: --	SCALE: 1:1
		DOCUMENT TYPE: Sales	SHEET 8 OF 17
		REL LEVEL: Released	REV: P

REV: PEO200

REV	DATE	DESCRIPTION	ECO	BY	C.H.K.
P	2019-08-13 01:00:00 EDT	Y425L100H ADDED TO SHEET 08	51969	YR	SS

CATALOG NUMBER	STRANDED COPPER CONDUCTOR ACCOMMODATED			BOLT SIZE	METRIC BOLT SIZE	DIMENSIONS							
	CODE (AWG)	NAVY	METRIC SIZE (CLASS 2)			B	C	K DIA.	L	N	O.D.	T REF.	Z MIN.
YA26L2	2/0 AWG	125	70mm ² STR [11]	1/4	M6	.94 [24]	.83 [21]	.27 [21]	1.94 [49]	.25 [6]	.56 [14]	.12 [3]	.33 [8]
YA26L3				5/16	----	.83 [21]	.33 [8]	2.06 [52]	.34 [9]	.12 [3]	.36 [9]		
YA26L				3/8	----	.83 [21]	.40 [10]	2.19 [56]	.41 [10]	.12 [3]	.42 [11]		
YA26L6				1/2	M12	.83 [21]	.53 [13]	2.44 [62]	.53 [13]	.12 [3]	.55 [14]		
YA26L7				5/8	M16	.90 [23]	.69 [18]	2.69 [68]	.66 [17]	.11 [3]	.67 [17]		
YA26L60				3/4	----	1.02 [26]	.81 [21]	2.96 [75]	.75 [19]	.10 [3]	.77 [20]		

CONNECTOR SIZE	TOLERANCES					
	B	C	K DIA.	L	N	O.D.
-8C THRU -25	±.06	±.04	±.02	±.09	±.03	±.01
-26 THRU -34	±.08	±.04	±.02	±.12	±.03	±.01
-35 AND UP	±.09	±.06	±.02	±.15	±.06	±.01

TOLERANCE BLOCK

CATALOG NO.	COLOR CODE	DIE INFORMATION		MECHANICAL				HYDRAULIC						DIELESS (# CRIMPS)	WIRE STRIP LENGTH	
		DIE INDEX	TYPE	YIMRTC	OUR840	MD6 MD7	MD6--R2 MD7-34R	Y500CT PATMD6 PAT600	Y34A Y34B Y34BH	Y35, Y39 Y750, PAT750	Y46 PAT46	Y45	Y48B			Y60BHU
YA26L2 YA26L3 YA26L YA26L6 YA26L7 YA26L60	BLACK	13	BLACK DIE SET NEST INDENTOR	----	X26RT(2)	X26RT(2) W26RT(2) W26VT(2)	X26RT(2) W26RT(2) W26VT(2)	X26RT(2) W26RT(2) W26VT(2)	-----	U26RT(1)	U26RT(1)	U26RT(1)	-----	-----	MECHANICAL MY29-3(1) MY29-11(1) MRC840 (2) HYDRAULIC: Y644 (1) Y81KFT (1) Y4PC834 (1)	1"

INSTALLATION TOOLING (# CRIMPS)

NOTES:

- MATERIAL: COPPER TUBING.
- FINISH: TIN PLATED.
"FOR ALTERNATIVE FINISH ADD ONE OF THE FOLLOWING SUFFIXES:
NICKEL = NK, LEAD = LD, BARE = BR, SILVER = SV"
- CATALOG # PT6515 ADAPTOR IS REQUIRED TO USE "U" DIES IN Y45 SERIES TOOLS.
- CATALOG # PUADP-1 ADAPTOR IS REQUIRED TO USE "U" DIES IN Y46 SERIES TOOLS.
- Y35P3 INDENTOR ADAPTOR REQUIRED FOR Y34PR INDENTOR.
- PERMANENT DIE IN TOOLING.
- DIMENSIONS IN BRACKETS [] ARE IN MILLIMETERS ROUNDED OFF TO THE NEAREST MILLIMETER, UNLESS OTHERWISE NOTED, AND ARE FOR REFERENCE ONLY.
- FOR USE BY CUSTOMERS THAT HAVE THIS HYPRESS™. NO NEW Y34A HYPRESS™ TOOLS ARE BEING PROCESSED. Y34A USES A--D NEST DIES ONLY.
- CONNECTORS ARE UL LISTED; UNDRILLED VERSIONS ARE NOT UL LISTED.
- CONNECTORS ARE CSA CERTIFIED. UNDRILLED VERSIONS ARE NOT CSA CERTIFIED.
- FOR UNDRILLED VERSIONS ADD SUFFIX "-U" TO END OF CATALOG NUMBER. FOR UNDRILLED VERSIONS, USE D MIN. = N MAX. + Z MIN.
- "X", "W-RT", "W-VT", "U" & "L" DIE SETS ARE COLOR CODED. "A", "B" AND "C" DIES ARE NOT COLOR CODED. NESTS AND INDENTOR TYPE ARE NOT COLOR CODED.
- THESE PARTS CAN BE ORDERED WITH NO INK MARKING ON THE BARREL. THE CATALOG NUMBERS FOR THESE PARTS ARE YA26L2G1, YA26L3G1, YA26LG1 AND YA26L6G1.

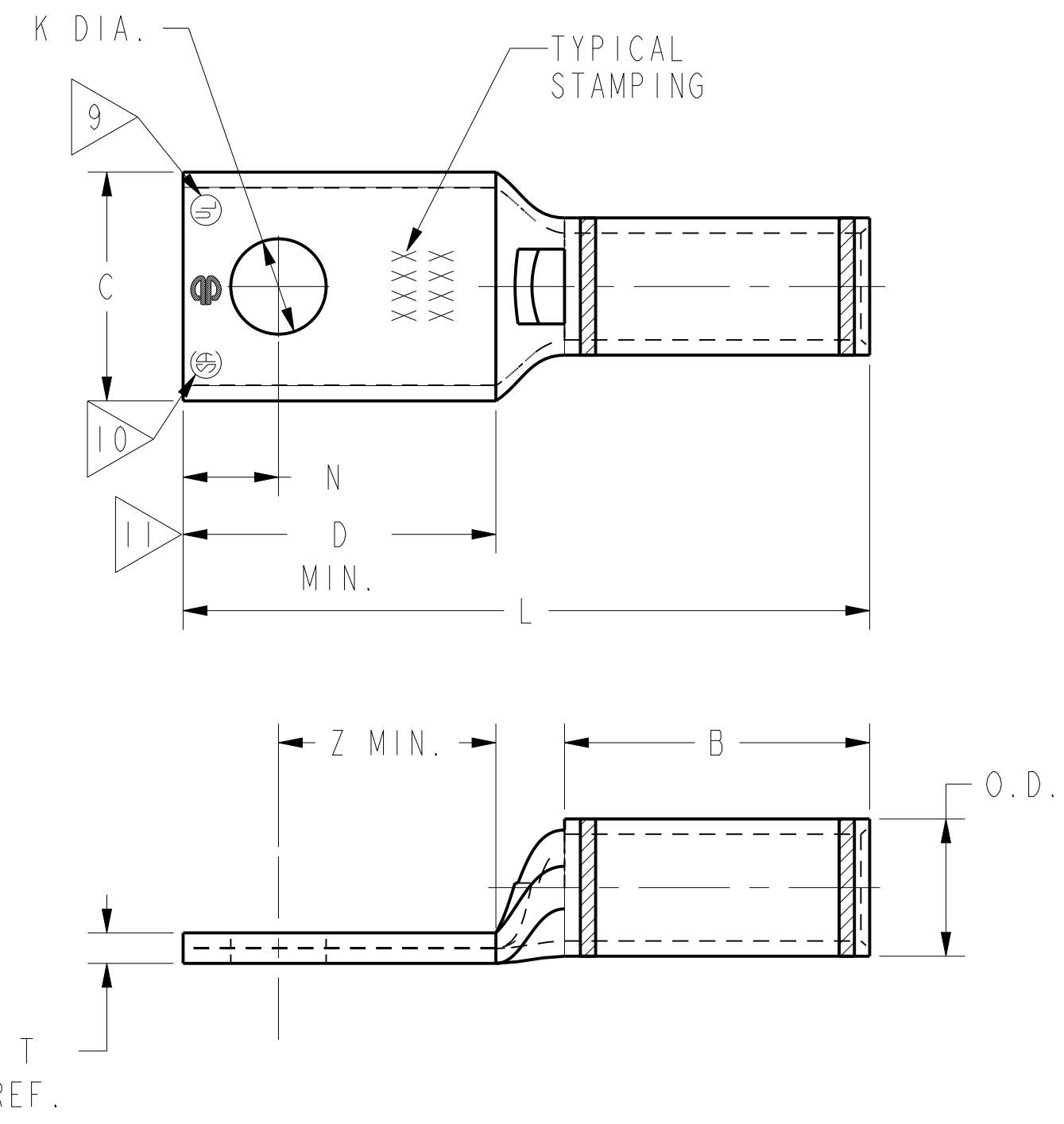

REFERENCE: SE209240

TO ORDER BURNDY® PRODUCTS CALL
 UNITED STATES
 1-800-346-4175 (LONDONDERRY, NH)
 CANADA:
 1-800-361-6975 (QUEBEC)
 1-800-387-6487 (ALL OTHER PROVINCES)
 FOR PRODUCT INFO: <http://www.burndy.com>

COPPER HYLUG™	
ITEM NO:	N/A
CAT. NO:	YA26-L (SEE TABLE)
DRAWN BY:	J MICHAUD 8/9/94
CHECKER:	D FILLION 10/9/94
DSN APPVL:	C PALAGI 8/19/94
MFG APPVL:	N/A
QA APPVL:	C ACKERMAN 9/30/94
MKT APPVL:	T NELSON 9/7/94
PROD FAM:	CM&R COMPRESSION
PROJECT #:	--
DOCUMENT TYPE:	Sales
REL LEVEL:	Released



SCALE: 1:1	DRAWING NO: SD079848	REV: P
SIZE: D	SHEET 9 OF 17	

REV	DATE	DESCRIPTION	ECO	BY	C.H.K.
P	12/21/2016 00:00:00 AM	Y425L100H ADDED TO SHEET 08	45555	YR	SS

CATALOG NUMBER	STRANDED COPPER CONDUCTOR ACCOMMODATED			BOLT SIZE	METRIC BOLT SIZE	DIMENSIONS							
	CODE (AWG)	NAVY	METRIC SIZE (CLASS 2)			B	C	K DIA.	L	N	O.D.	T REF.	Z MIN.
YA27L2	3/0 AWG	150	----	1/4	M6	1.00 [25]	.91 [23]	.27 [7]	2.04 [52]	.25 [6]	.62 [16]	.13 [3]	.33 [8]
YA27L3				5/16	----	.33 [8]	2.16 [55]	.34 [9]	.62 [16]	.13 [3]	.36 [9]		
YA27L4				3/8	----	.40 [10]	2.29 [58]	.41 [10]	.62 [16]	.13 [3]	.42 [11]		
YA27L				1/2	M12	1.00 [25]	.91 [23]	.53 [13]	2.54 [65]	.53 [13]	.62 [16]	.13 [3]	.55 [14]
YA28L2	4/0 AWG	200	----	1/4	M6	.88 [22]	1.02 [26]	.27 [7]	1.96 [50]	.25 [6]	.69 [18]	.14 [4]	.33 [8]
YA28L3				5/16	----	.33 [8]	2.08 [53]	.34 [9]	.69 [18]	.14 [4]	.36 [9]		
YA28L4				3/8	----	.40 [10]	2.21 [56]	.41 [10]	.69 [18]	.14 [4]	.42 [11]		
YA28L				1/2	M12	.53 [13]	2.46 [62]	.53 [13]	.69 [18]	.14 [4]	.55 [14]		
YA28LUNPL				1/2	M12	.53 [13]	2.46 [62]	.53 [13]	1.02 [26]	.14 [4]	.55 [14]		
YA28L17				5/8	M16	.69 [18]	2.71 [69]	.66 [17]	.69 [18]	.13 [3]	.67 [17]		
YA28L56				3/4	----	.88 [22]	1.05 [27]	.81 [21]	2.90 [74]	.75 [19]	.69 [18]	.13 [3]	.77 [20]

CONNECTOR SIZE	TOLERANCES					
	B	C	K DIA.	L	N	O.D.
-8C THRU -25	±.06	±.04	±.02	±.09	±.03	±.01
-26 THRU -34	±.08	±.04	±.02	±.12	±.03	±.01
-35 AND UP	±.09	±.06	±.02	±.15	±.06	±.01

TOLERANCE BLOCK

CATALOG NO.	COLOR CODE	DIE INFORMATION		MECHANICAL				HYDRAULIC						DIELESS (# CRIMPS)	WIRE STRIP LENGTH	
		DIE INDEX	TYPE	YIMRTC 6	OUR840	MD6 MD7	MD6--R2 MD7-34R	Y500CT PATMD6 PAT600	Y34A Y34B Y34BH 8	Y35, Y39 Y750, PAT750 5	Y46 PAT46 4 5	Y45 3 5	Y48B			Y60BHU
YA27L2 YA27L3 YA27L4 YA27L	ORANGE	14	ORANGE DIE SET NEST INDENTOR	----	X27RT(3)	X27RT(3) W27RT(2) W27VT(2)	X27RT(3) W27RT(2) W27VT(2)	X27RT(3) W27RT(2) W27VT(2)	-----	U27RT(1)	U27RT(1)	U27RT(1)	-----	-----	MECHANICAL MY29-3(1) MY29-11(1) MRC840 (2)	1-1/16"
YA28L2 YA28L3 YA28L4 YA28L YA28L17 YA28L56 YA28LUNPL 14	PURPLE	15	PURPLE DIE SET NEST INDENTOR	----	X28RT(3)	X28RT(3) W28RT(2) W28VT(2)	X28RT(3) W28RT(2) W28VT(2)	X28RT(3) W87RT(2) W28VT(2)	-----	U28RT(1)	U28RT(1)	U28RT(1)	C28R(1)	L28RT(1)	HYDRAULIC: Y644 (1) Y81KFT (2) Y4PC834 (2)	1-1/8"

- NOTES:
- MATERIAL: COPPER TUBING.
 - FINISH: TIN PLATED.
"FOR ALTERNATIVE FINISH ADD ONE OF THE FOLLOWING SUFFIXES:
NICKEL = NK, LEAD = LD, BARE = BR, SILVER = SV"
 - CATALOG # PT6515 ADAPTOR IS REQUIRED TO USE "U" DIES IN Y45 SERIES TOOLS.
 - CATALOG # PUADP-1 ADAPTOR IS REQUIRED TO USE "U" DIES IN Y46 SERIES TOOLS.
 - Y35P3 INDENTOR ADAPTOR REQUIRED FOR Y34PR INDENTOR.
 - PERMANENT DIE IN TOOLING.
 - DIMENSIONS IN BRACKETS [] ARE IN MILLIMETERS ROUNDED OFF TO THE NEAREST MILLIMETER, UNLESS OTHERWISE NOTED, AND ARE FOR REFERENCE ONLY.
 - FOR USE BY CUSTOMERS THAT HAVE THIS HYPRESS™. NO NEW Y34A HYPRESS™ TOOLS ARE BEING PROCESSED. Y34A USES A--D NEST DIES ONLY.
 - CONNECTORS ARE UL LISTED; UNDRILLED VERSIONS ARE NOT UL LISTED.
 - CONNECTORS ARE CSA CERTIFIED. UNDRILLED VERSIONS ARE NOT CSA CERTIFIED.
 - FOR UNDRILLED VERSIONS ADD SUFFIX "-U" TO END OF CATALOG NUMBER.
FOR UNDRILLED VERSIONS, USE D MIN. = N MAX. + Z MIN.
 - "X", "W-RT", "W-VT", "U" & "L" DIE SETS ARE COLOR CODED. "A", "B" AND "C" DIES ARE NOT COLOR CODED. NESTS AND INDENTOR TYPE ARE NOT COLOR CODED.
 - THESE PARTS CAN BE ORDERED WITH NO INK MARKING ON THE BARREL. THE CATALOG NUMBERS FOR THESE PARTS ARE YA27L2G1, YA27L3G1, YA27L4G1, YA27LG1, YA28L4G1, YA28LG1 AND YA28L3G1.
 - ADD SUFFIX "UNPL" FOR UNPLATED CONNECTORS WITH NO BARREL MARKINGS.

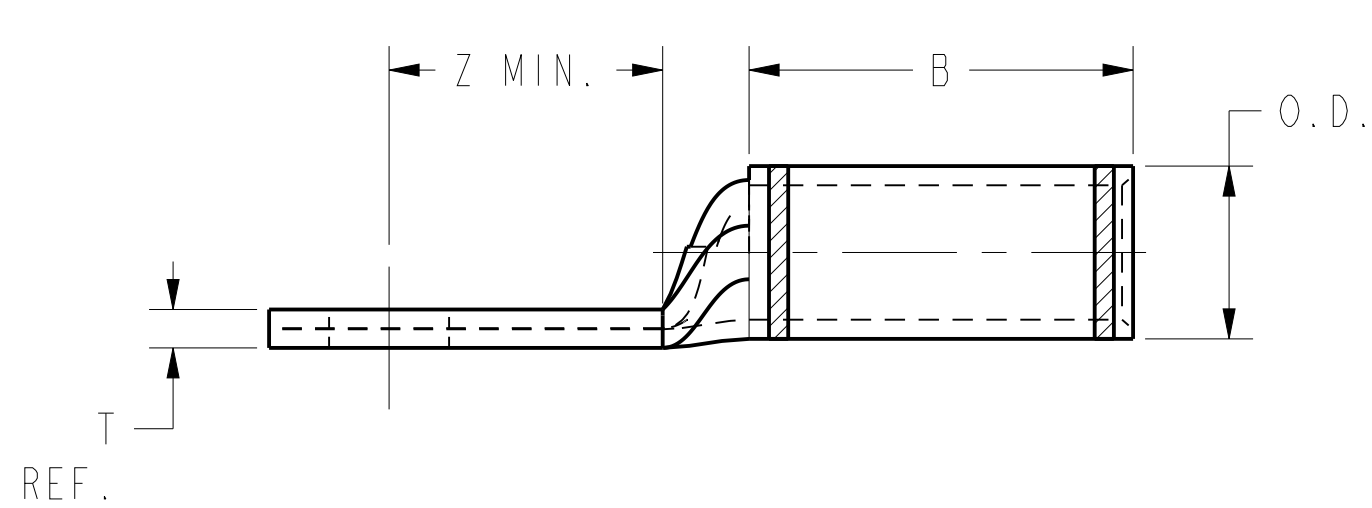
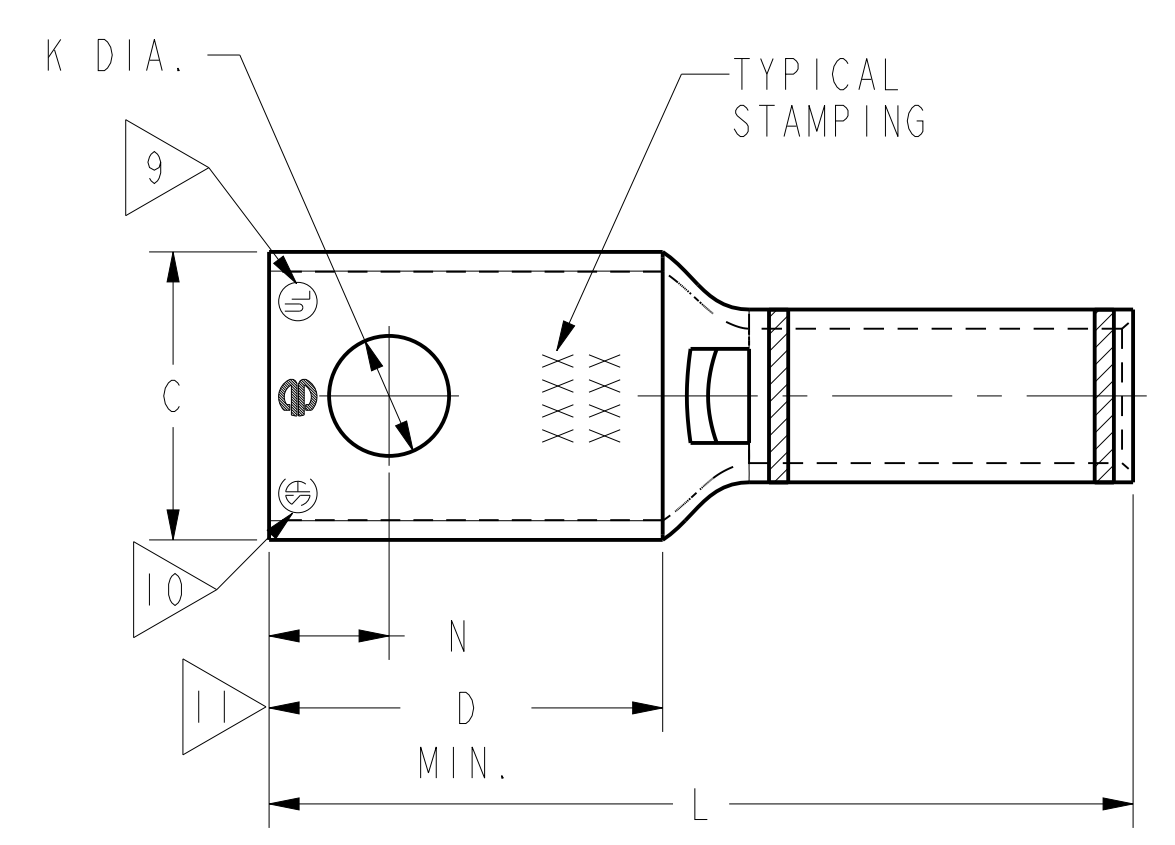

REFERENCE: SE209240

TO ORDER BURNDY® PRODUCTS CALL		COPPER HYLUG™	
UNITED STATES 1-800-346-4175 (LONDONDERRY, NH)		ITEM NO: N/A	CAT. NO: YA27-L, YA28-L (SEE TABLE)
CANADA: 1-800-361-6975 (QUEBEC) 1-800-387-6487 (ALL OTHER PROVINCES)		DRAWN BY: J MICHAUD 08/08/1994	CHECKER: D FILLION 10/03/1994
FOR PRODUCT INFO: http://www.burndy.com		DSN APPVL: C PALAGI 08/19/1994	MFG APPVL: N/A N/A
		GA APPVL: C ACKERMAN 08/30/1994	MKT APPVL: T NELSON 09/07/1994
		PROD FAM: CM&R COMPRESSION	DRAWING NO: SD079848
		PROJECT #: --	SCALE: 1:1
		DOCUMENT TYPE: Sales	REV: P
		REL LEVEL: Released	SHEET 10 OF 17

REV	DATE	DESCRIPTION	ECO	BY	C.H.K.
P	2019-08-13 01:00:00 EDT	Y45L/100H ADDED TO SHEET 08	51969	YR	SS

CATALOG NUMBER	STRANDED COPPER CONDUCTOR ACCOMMODATED			BOLT SIZE	METRIC BOLT SIZE	DIMENSIONS							
	CODE (AWG)	NAVY	METRIC SIZE (CLASS 2)			B	C	K DIA.	L	N	O.D.	T REF.	Z MIN.
YA29L2	250 kcmil	250	120mm ² STR [14.5]	1/4	M6	1.06 [27]	1.11 [28]	.27 [7]	2.17 [55]	.25 [6]	.75 [19]	.16 [4]	.33 [8]
YA29L7				5/16	----	.33 [8]	2.30 [58]	.34 [9]	.75 [19]	.16 [4]	.36 [9]		
YA29L4				3/8	----	.40 [10]	2.42 [61]	.41 [10]	.75 [19]	.16 [4]	.42 [11]		
YA29L				1/2	M12	.53 [13]	2.67 [68]	.53 [13]	.75 [19]	.16 [4]	.55 [14]		
YA29LTC78				7/8	----	1.06 [27]	1.11 [28]	.94 [24]	3.36 [85]	.88 [22]	.75 [19]	.14 [4]	.89 [23]
YA30L1	300 kcmil	300	150mm ² STR [16.2]	5/16	----	1.03 [26]	1.20 [30]	.33 [8]	2.31 [59]	.34 [9]	.81 [21]	.16 [4]	.36 [9]
YA30L24				3/8	----	.40 [10]	2.44 [62]	.41 [10]	.81 [21]	.16 [4]	.42 [11]		
YA30L				1/2	M12	.53 [13]	2.69 [68]	.53 [13]	.81 [21]	.16 [4]	.55 [14]		
YA30LUNPL				1/2	M12	.53 [13]	2.69 [68]	.53 [13]	.81 [21]	.16 [4]	.55 [14]		
YA30L7				5/8	M16	.69 [18]	2.94 [75]	.66 [17]	.81 [21]	.16 [4]	.67 [17]		
YA30L27				7/8	----	1.20 [30]	3.37 [86]	.88 [22]	.81 [21]	.16 [4]	.89 [23]		
YA30L28				3/4	----	1.03 [26]	1.20 [30]	.81 [20]	3.12 [80]	.75 [19]	.81 [21]	.16 [4]	.77 [19]

CONNECTOR SIZE	TOLERANCES					
	B	C	K DIA.	L	N	O.D.
-8C THRU -25	±.06	±.04	±.02	±.09	±.03	±.01
-26 THRU -34	±.08	±.04	±.02	±.12	±.03	±.01
-35 AND UP	±.09	±.06	±.02	±.15	±.06	±.01

TOLERANCE BLOCK

CATALOG NO.	COLOR CODE	DIE INFORMATION		MECHANICAL RATCHET				HYDRAULIC						DIELESS (# CRIMPS)	WIRE STRIP LENGTH	
		DIE INDEX	TYPE	YIMRTC	OUR840	MD6 MD7	MD6--R2 MD7-34R	Y500CT PATMD6 PAT600	Y34A Y34B Y34BH	Y35, Y39 Y750, PAT750	Y46 PAT46	Y45	Y48B			Y60BHU
YA29L2 YA29L7 YA29L4 YA29L YA29LTC78	YELLOW	16	YELLOW DIE SET NEST INDENTOR	----	X29RT(4)	X29RT(4) W29VT(2)	X29RT(4) W29RT(2) W29VT(2)	X29RT(4) W29RT(2) W29VT(2)	A29R(1)	U29RT(1)	U29RT(1)	U29RT(1)	C29R(1)	L29RT(1)	MECHANICAL MY29-3 (1) MY29-11 (1) HYDRAULIC: Y644 (1) Y81KFT (2) Y4PC834 (2)	1-1/8"
YA30L1 YA30L24 YA30L YA30L7 YA30L27 YA30L28 YA30LUNPL	WHITE	17 298	WHITE DIE SET NEST INDENTOR	----	----	W30VT(2)	W30RT(2) W30VT(2)	W30RT(2) W30VT(2)	A28AR(1)	U30RT(2) U28ART(2)	U30RT(2) U28ART(2)	U30RT(2) U28ART(2)	C30R(2) C28AR(2)	L30RT(1)	HYDRAULIC: Y644 (1) Y81KFT (2) Y4PC834 (2)	1-1/6"

- NOTES:
- MATERIAL: COPPER TUBING.
 - FINISH: TIN PLATED.
"FOR ALTERNATIVE FINISH ADD ONE OF THE FOLLOWING SUFFIXES:
NICKEL = NK, LEAD = LD, BARE = BR, SILVER = SV"
 - CATALOG # PT6515 ADAPTOR IS REQUIRED TO USE "U" DIES IN Y45 SERIES TOOLS.
 - CATALOG # PUADP-1 ADAPTOR IS REQUIRED TO USE "U" DIES IN Y46 SERIES TOOLS.
 - Y35P3 INDENTOR ADAPTOR REQUIRED FOR Y34PR INDENTOR.
 - PERMANENT DIE IN TOOLING.
 - DIMENSIONS IN BRACKETS [] ARE IN MILLIMETERS ROUNDED OFF TO THE NEAREST MILLIMETER, UNLESS OTHERWISE NOTED, AND ARE FOR REFERENCE ONLY.
 - FOR USE BY CUSTOMERS THAT HAVE THIS HYPRESS™. NO NEW Y34A HYPRESS™ TOOLS ARE BEING PROCESSED. Y34A USES A--D NEST DIES ONLY.
 - CONNECTORS ARE UL LISTED; UNDRILLED VERSIONS ARE NOT UL LISTED.
 - CONNECTORS ARE CSA CERTIFIED. UNDRILLED VERSIONS ARE NOT CSA CERTIFIED.
 - FOR UNDRILLED VERSIONS ADD SUFFIX "-U" TO END OF CATALOG NUMBER.
FOR UNDRILLED VERSIONS, USE D MIN. = N MAX. + Z MIN.
 - "X", "W-RT", "W-VT", "U" & "L" DIE SETS ARE COLOR CODED. "A", "B" AND "C" DIES ARE NOT COLOR CODED. NESTS AND INDENTOR TYPE ARE NOT COLOR CODED.
 - ADD SUFFIX "UNPL" FOR UNPLATED CONNECTORS WITH NO BARREL MARKINGS.

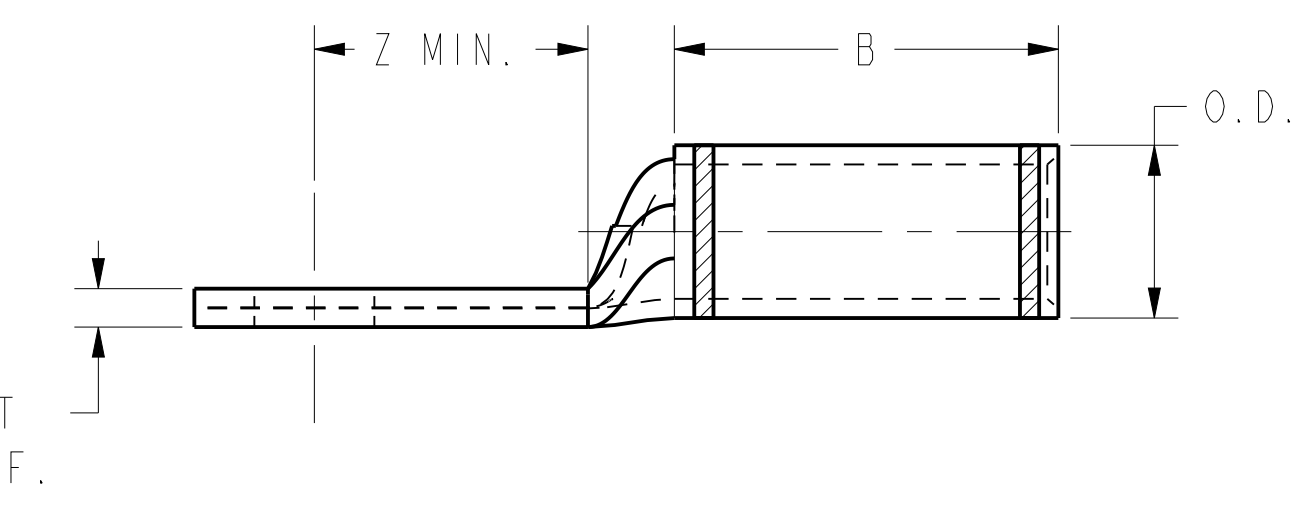
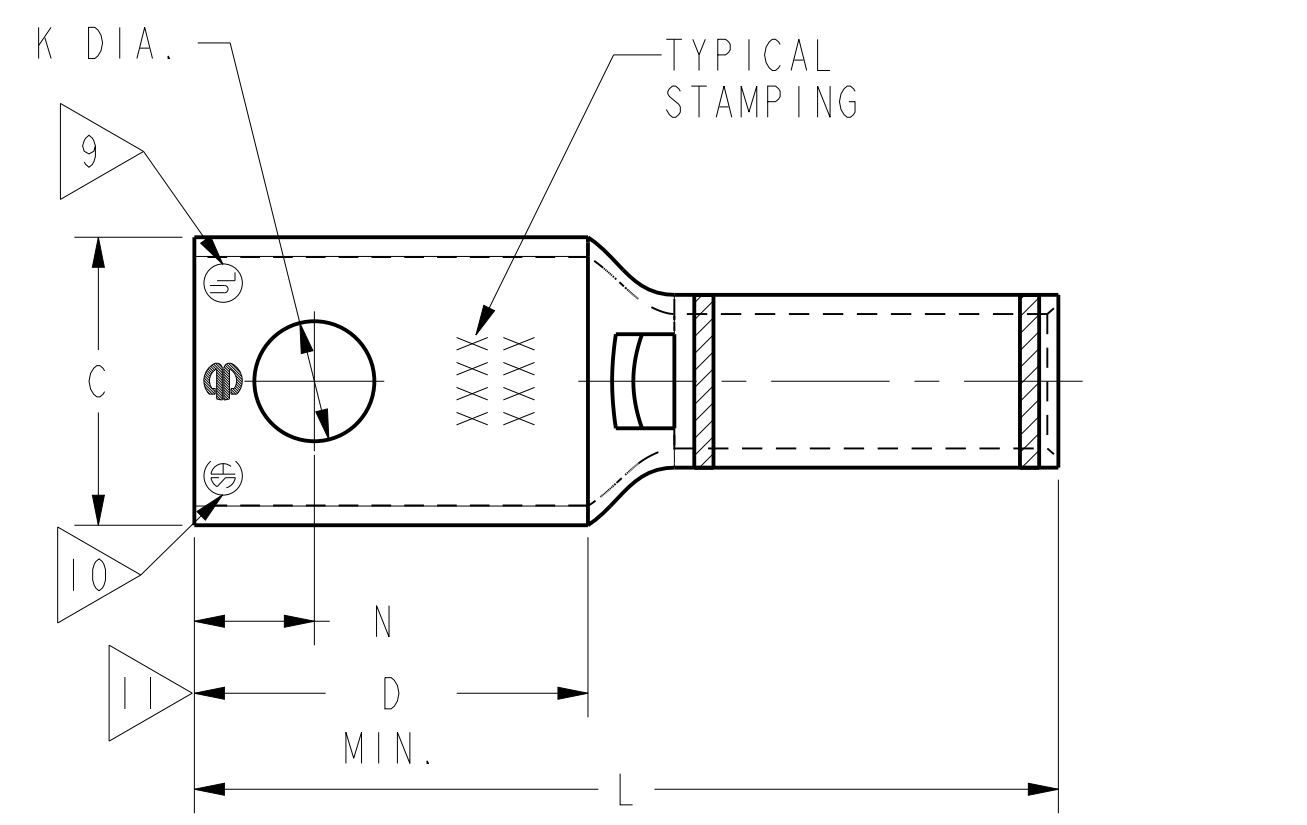

REFERENCE: SE209240

TO ORDER BURNDY® PRODUCTS CALL		COPPER HYLUG™	
UNITED STATES 1-800-346-4175 (LONDONDERRY, NH)		ITEM NO: N/A	CAT. NO: YA-L, YA-L-TC-, YAV-TC-
CANADA: 1-800-361-6975 (QUEBEC) 1-800-387-6487 (ALL OTHER PROVINCES)		DRAWN BY: J MICHAUD 8/9/94	CHECKER: D FILLION 10/3/94
FOR PRODUCT INFO: http://www.burndy.com		DSN APPVL: C PALAGI 8/19/94	MFG APPVL: N/A N/A
		QA APPVL: C ACKERMAN 9/30/94	MKT APPVL: T NELSON 9/7/94
		PROD FAM: CM&R COMPRESSION	DRAWING NO: SD079848
		PROJECT #: --	SCALE: 1:1
		DOCUMENT TYPE: Sales	REV: P
		REL LEVEL: Released	SHEET 11 OF 17

REV	DATE	DESCRIPTION	ECO	BY	C'H'K.
P	2019-08-13 01:00:00 EDT	Y42L1001 ADDED TO SHEET 00	51969	YR	SS

CATALOG NUMBER	STRANDED COPPER CONDUCTOR ACCOMMODATED			BOLT SIZE	METRIC BOLT SIZE	DIMENSIONS							
	CODE (AWG)	NAVY	METRIC SIZE (CLASS 2)			B	C	K DIA.	L	N	O.D.	T REF.	Z MIN.
YA31L11	350 kcmil	350	----	3/8	----	1.06 [27]	1.29 [33]	.40 [10]	2.50 [64]	.41 [10]	.88 [22]	.18 [5]	.42 [11]
YA31L				1/2	M12			.53 [13]	2.75 [70]	.53 [13]			.55 [14]
YA31L7				5/8	M16			.69 [18]	3.00 [76]	.66 [17]			.67 [17]
YA31L36				7/8	----			.94 [24]	4.02 [102]	1.19 [30]			1.16 [29]
YA31L38				3/4	M10			1.06 [27]	1.29 [33]	.81 [21]	3.16 [80]	.75 [19]	.88 [22]
YA32L14	400 kcmil	400	----	3/8	----	1.19 [30]	1.40 [36]	.40 [10]	2.68 [68]	.41 [10]	.95 [24]	.19 [5]	.42 [11]
YA32L1				1/2	M12			.53 [13]	2.93 [74]	.53 [13]			.55 [14]
YA32L1UNPL				5/8	M16			.69 [18]	3.18 [81]	.67 [17]			.67 [17]
YA32L				7/8	----			1.19 [30]	1.40 [36]	.94 [24]	3.62 [92]	.88 [22]	.95 [24]
YA32LTC78	450 kcmil	----	----	5/8	M16	1.50 [38]	1.48 [38]	.69 [18]	3.57 [91]	.66 [17]	1.01 [26]	.21 [5]	.67 [17]
YA33L													

CONNECTOR SIZE	TOLERANCES					
	B	C	K DIA.	L	N	O.D.
-8C THRU -25	±.06	±.04	±.02	±.09	±.03	±.01
-26 THRU -34	±.08	±.04	±.02	±.12	±.03	±.01
-35 AND UP	±.09	±.06	±.02	±.15	±.06	±.01

TOLERANCE BLOCK

CATALOG NO.	COLOR CODE	INSTALLATION TOOLING (# CRIMPS)														DIELESS (# CRIMPS)	WIRE STRIP LENGTH
		DIE INFORMATION		MECHANICAL RATCHET				HYDRAULIC									
		DIE INDEX	TYPE	YIMRTC	OUR840	MD6 MD7	MD6--R2 MD7-34R	Y500CT PATMD6 PAT600	Y34A Y34B Y34BH	Y35, Y39 Y750, PAT750	Y46 PAT46	Y45	Y48B	Y60BHU			
YA31L11 YA31L YA31L7 YA31L36 YA31L38	RED	18 324	RED DIE SET NEST INDENTOR	----	----	W31VT(2)	W31RT(2) W31VT(2)	W31VT(2) W31RT(2)	----	U31RT(2) U29ART(2)	U31RT(2) U29ART(2)	U31RT(2) U29ART(2)	C31R(2) C29AR(2)	L31RT(1) L29ART(1)	HYDRAULIC: Y644 (1) Y81KFT (2) Y4PC834 (2)	1-1/8"	
YA32L14 YA32L1 YA32L1UNPL YA32L YA32LTC78	BLUE	19 470	BLUE DIE SET NEST INDENTOR	----	----	W32VT(2)	W32RT(2) W32VT(2)	W32VT(2) W32RT(2)	----	U32RT(2) U30ART(2)	U32RT(2) U30ART(2)	U32RT(2) U30ART(2)	C32R(2) C30AR(2)	L32RT(1) L30ART(1)			
YA33L	GRAY	326 538	GRAY DIE SET NEST INDENTOR	----	----	W33VT(2)	W33RT(2) W33VT(2)	W33VT(2) W33RT(2)	----	U33RT(2)	U33RT(2)	U33RT(2)	----	L33RT(1)			

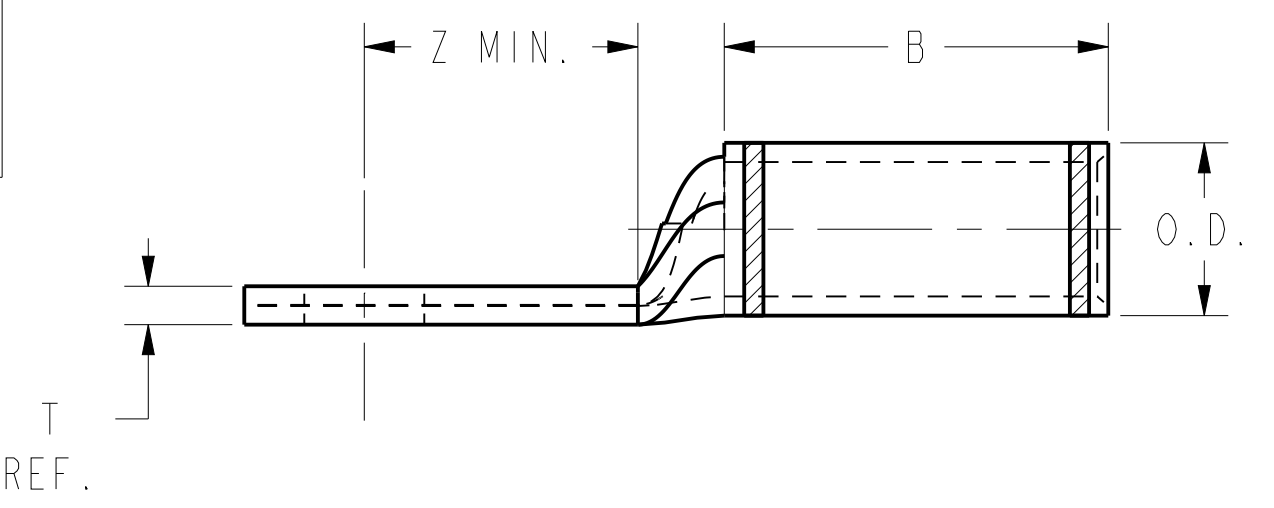
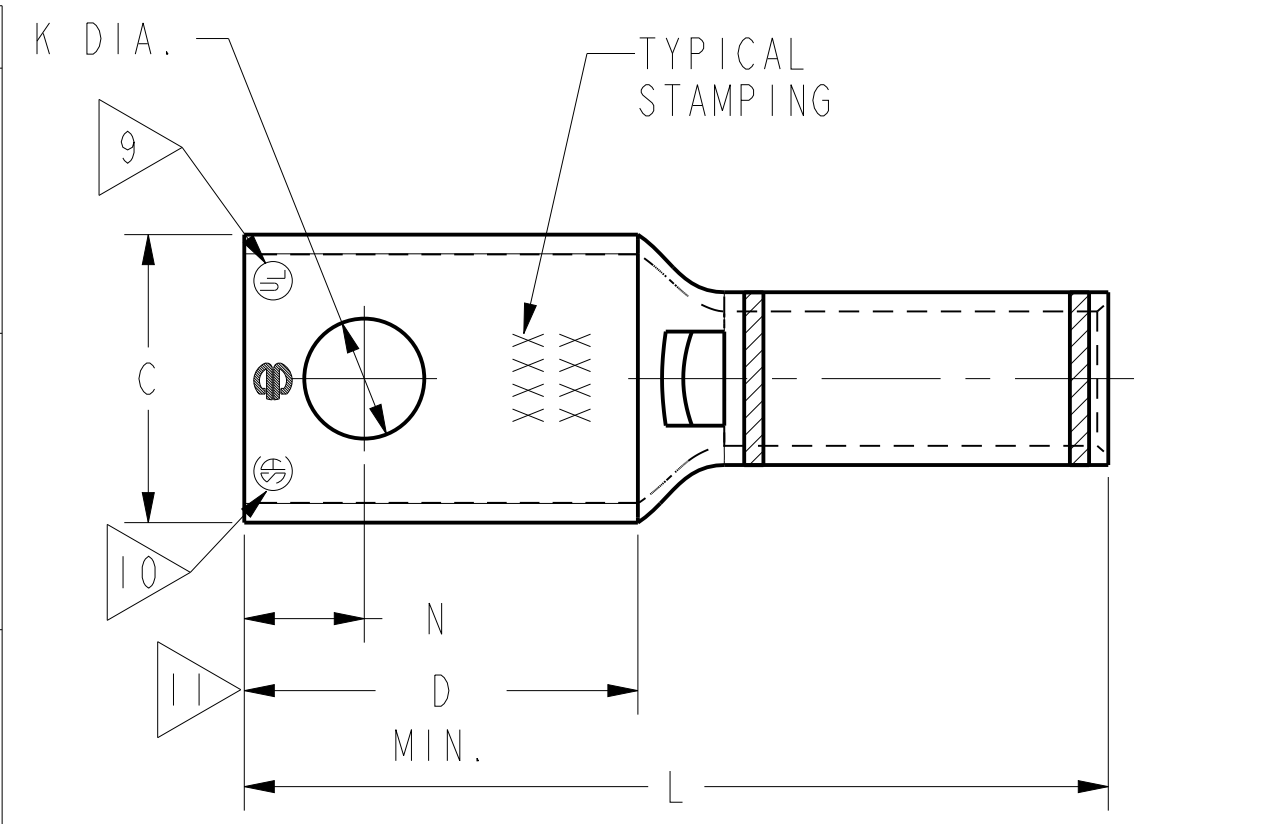

NOTES:

- MATERIAL: COPPER TUBING.
- FINISH: TIN PLATED.
"FOR ALTERNATIVE FINISH ADD ONE OF THE FOLLOWING SUFFIXES:
NICKEL = NK, LEAD = LD, BARE = BR, SILVER = SV"
- CATALOG # PT6515 ADAPTOR IS REQUIRED TO USE "U" DIES IN Y45 SERIES TOOLS.
- CATALOG # PUADP-1 ADAPTOR IS REQUIRED TO USE "U" DIES IN Y46 SERIES TOOLS.
- Y35P3 INDENTOR ADAPTOR REQUIRED FOR Y34PR INDENTOR.
- PERMANENT DIE IN TOOLING.
- DIMENSIONS IN BRACKETS [] ARE IN MILLIMETERS ROUNDED OFF TO THE NEAREST MILLIMETER, UNLESS OTHERWISE NOTED, AND ARE FOR REFERENCE ONLY.
- FOR USE BY CUSTOMERS THAT HAVE THIS HYPRESS™. NO NEW Y34A HYPRESS™ TOOLS ARE BEING PROCESSED. Y34A USES A--D NEST DIES ONLY.
- CONNECTORS ARE UL LISTED; UNDRILLED VERSIONS ARE NOT UL LISTED.
- CONNECTORS ARE CSA CERTIFIED. UNDRILLED VERSIONS ARE NOT CSA CERTIFIED.
- FOR UNDRILLED VERSIONS ADD SUFFIX "-U" TO END OF CATALOG NUMBER.
FOR UNDRILLED VERSIONS, USE D MIN. = N MAX. + Z MIN.
- "X", "W-RT", "W-VT", "U" & "L" DIE SETS ARE COLOR CODED. "A", "B" AND "C" DIES ARE NOT COLOR CODED. NESTS AND INDENTOR TYPE ARE NOT COLOR CODED.

13 ADD SUFFIX "UNPL" FOR UNPLATED CONNECTORS WITH NO BARREL MARKINGS.

REFERENCE: SE209240

TO ORDER BURNDY® PRODUCTS CALL UNITED STATES 1-800-346-4175 (LONDONDERRY, NH) CANADA: 1-800-361-6975 (QUEBEC) 1-800-387-6487 (ALL OTHER PROVINCES) FOR PRODUCT INFO: http://www.burndy.com	COPPER HYLUG™		
	ITEM NO:	N/A	
	CAT. NO:	YA-L, YA-L-TC-, YAV-TC-	
	DRAWN BY:	J MICHARD	8/9/94
	CHECKER:	D FILLION	10/9/94
	DSN APPVL:	C PALAGI	8/19/94
	MFG APPVL:	N/A	N/A
	QA APPVL:	C ACKERMAN	9/30/94
	MKT APPVL:	T NELSON	9/7/94
	PROD FAM:	CM&R COMPRESSION	DRAWING NO
PROJECT #:	--	SIZE	
DOCUMENT TYPE:	Sales	SD079848	
REL LEVEL:	Released	D	
		SHEET 12 OF 17	

REV: PEO200

REV	DATE	DESCRIPTION	ECO	BY	C.H.K.
P	2019-08-13 01:00:00 EDT	Y425/1008 ADDED TO SHEET 08	51969	YR	SS

CATALOG NUMBER	STRANDED COPPER CONDUCTOR ACCOMMODATED			BOLT SIZE	METRIC BOLT SIZE	DIMENSIONS							
	CODE (AWG)	NAVY	METRIC SIZE (CLASS 2)			B	C	K DIA.	L	N	O.D.	T REF.	Z MIN.
YA34L37	500 Kcmil ↑ 500 Kcmil	-----	240mm ² STR [23.1]	3/8	----	1.27 [32]	1.55 [39]	.40 [10]	2.87 [73]	.41 [10]	1.06 [27]	.23 [6]	.42 [11]
YA34L6				1/2	M12	1.27 [32]	1.55 [39]	.53 [13]	3.12 [79]	.53 [13]	1.06 [27]	.23 [6]	.55 [14]
YA34L				5/8	M16	1.27 [32]	1.55 [39]	.69 [18]	3.37 [86]	.66 [17]	1.06 [27]	.23 [6]	.67 [17]
YA34L8				3/4	----	1.27 [32]	1.55 [39]	.81 [21]	3.55 [90]	.75 [19]	1.06 [27]	.23 [6]	.77 [20]
YA34L9				7/8	----	1.27 [32]	1.55 [39]	.94 [24]	3.80 [97]	.88 [22]	1.06 [27]	.23 [6]	.89 [23]
YA34L20				1	----	1.27 [32]	1.55 [39]	1.07 [27]	4.05 [103]	1.00 [25]	1.06 [27]	.23 [6]	1.02 [26]

CONNECTOR SIZE	TOLERANCES					
	B	C	K DIA.	L	N	O.D.
-8C THRU -25	±.06	±.04	±.02	±.09	±.03	±.01
-26 THRU -34	±.08	±.04	±.02	±.12	±.03	±.01
-35 AND UP	±.09	±.06	±.02	±.15	±.06	±.01

TOLERANCE BLOCK

INSTALLATION TOOLING (# CRIMPS)																
CATALOG NO.	COLOR CODE	DIE INFORMATION		MECHANICAL RATCHET				HYDRAULIC						DIELESS (# CRIMPS)	WIRE STRIP LENGTH	
		DIE INDEX	TYPE	YIMRTC 6	OUR840	MD6 MD7	MD6--R2 MD7-34R	Y500CT PATMD6 PAT600	Y34A 8 Y34B Y34BH	Y35, Y39 Y750, PAT750 5	Y46 4 PAT46 5	Y45 3 5	Y48B			Y60BHU
YA34L37 YA34L6 YA34L YA34L8 YA34L9 YA34L20	BROWN	20 299	BROWN DIE SET NEST INDENTOR	----	----	W34VT(2)	W34RT(2) W34VT(2)	W34VT(2) W34RT(2)	-----	U34RT(2) U31ART(1)	U34RT(2) P34RT(2) U31ART(1)	U34RT(2) U31ART(1)	C34R(1) C31AR(1)	L34RT(1)	HYDRAULIC: Y644 (1) Y81KFT (2) Y4PC834 (2)	1-7/16"
									Y34PR	Y34PR	Y34PR	Y34PR	Y48PR			

- NOTES:**
- MATERIAL: COPPER TUBING.
 - FINISH: TIN PLATED.
"FOR ALTERNATIVE FINISH ADD ONE OF THE FOLLOWING SUFFIXES:
NICKEL = NK, LEAD = LD, BARE = BR, SILVER = SV"
 - CATALOG # PT6515 ADAPTOR IS REQUIRED TO USE "U" DIES IN Y45 SERIES TOOLS.
 - CATALOG # PUADP-1 ADAPTOR IS REQUIRED TO USE "U" DIES IN Y46 SERIES TOOLS.
 - Y35P3 INDENTOR ADAPTOR REQUIRED FOR Y34PR INDENTOR.
 - PERMANENT DIE IN TOOLING.
 - DIMENSIONS IN BRACKETS [] ARE IN MILLIMETERS ROUNDED OFF TO THE NEAREST MILLIMETER, UNLESS OTHERWISE NOTED, AND ARE FOR REFERENCE ONLY.
 - FOR USE BY CUSTOMERS THAT HAVE THIS HYPRESS™. NO NEW Y34A HYPRESS™ TOOLS ARE BEING PROCESSED. Y34A USES A--D NEST DIES ONLY.
 - CONNECTORS ARE UL LISTED; UNDRILLED VERSIONS ARE NOT UL LISTED.
 - CONNECTORS ARE CSA CERTIFIED. UNDRILLED VERSIONS ARE NOT CSA CERTIFIED.
 - FOR UNDRILLED VERSIONS ADD SUFFIX "-U" TO END OF CATALOG NUMBER.
FOR UNDRILLED VERSIONS, USE D MIN. = N MAX. + Z MIN.
 - "X", "W-RT", "W-VT", "U" & "L" DIE SETS ARE COLOR CODED. "A", "B" AND "C" DIES ARE NOT COLOR CODED. NESTS AND INDENTOR TYPE ARE NOT COLOR CODED.

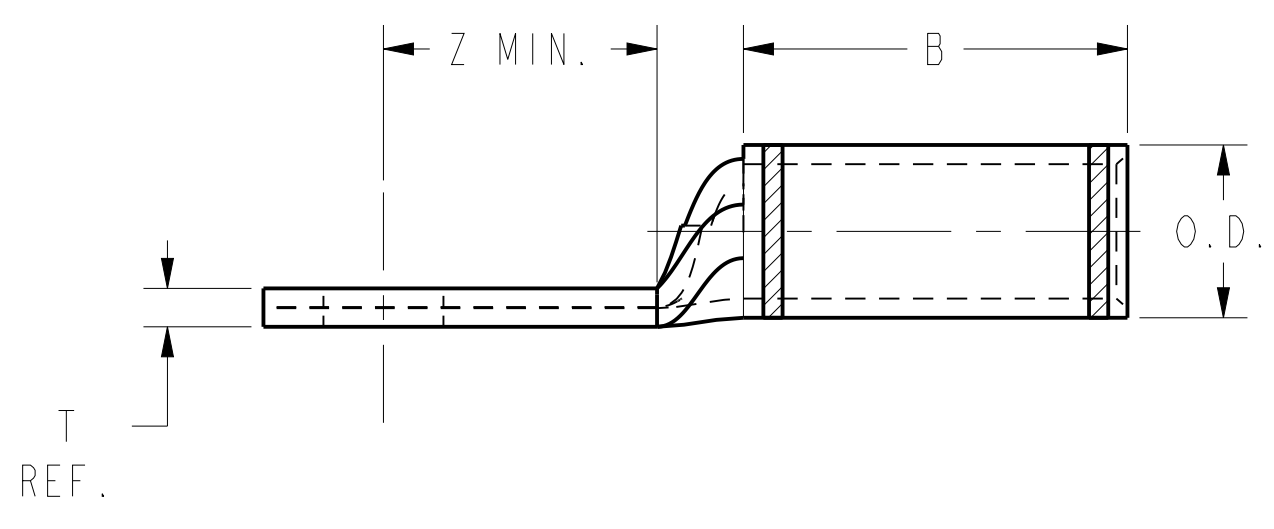
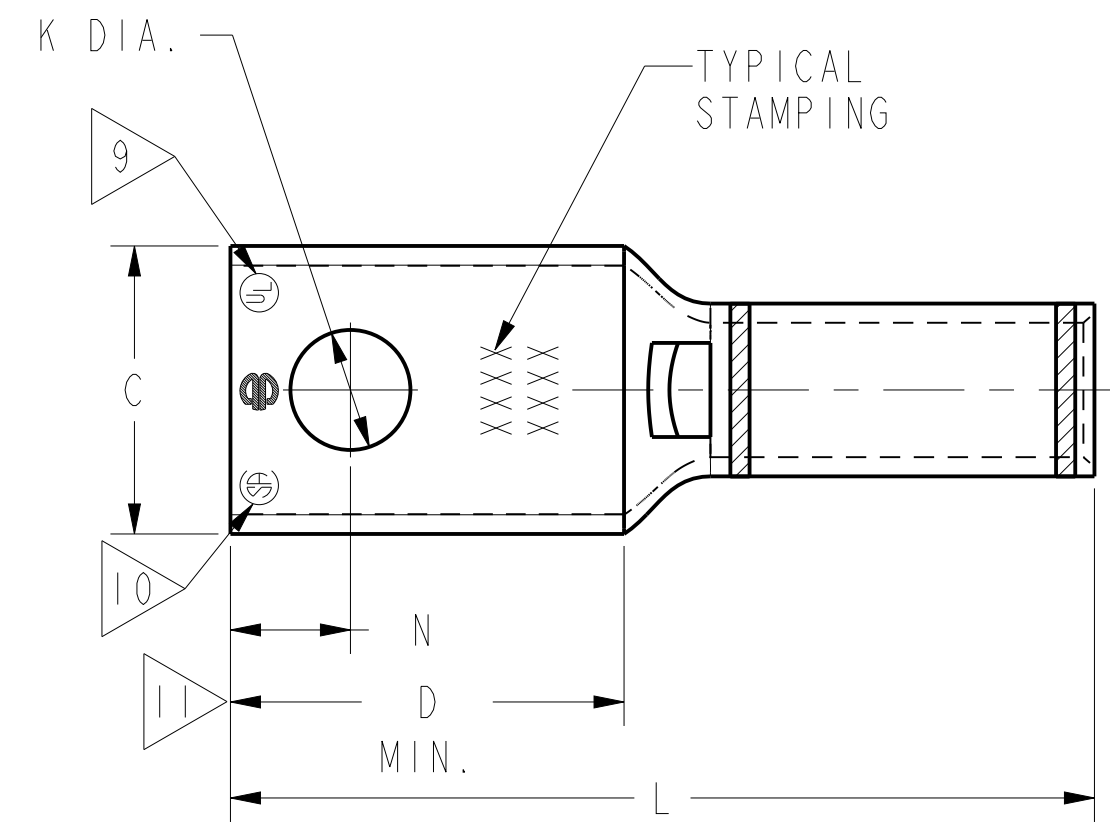

REFERENCE: SE209240

TO ORDER BURNDY® PRODUCTS CALL		HYLUG™ COPPER	
UNITED STATES 1-800-346-4175 (LONDONDERRY, NH)		ITEM NO: N/A	CAT. NO: YA-L, YA-L-TC-, YAV-TC-
CANADA: 1-800-387-6487 (ALL OTHER PROVINCES)		DRAWN BY: J MICHAUD 8/10/94	CHECKER: D FILLION 10/3/94
FOR PRODUCT INFO: http://www.burndy.com		DSN APPVL: C PALAGI 8/19/94	MFG APPVL: N/A N/A
		GA APPVL: C ACKERMAN 9/30/94	MKT APPVL: T NELSON 9/30/94
		PROD FAM: CM&R COMPRESSION	DRAWING NO: SD079848
		PROJECT #: --	SCALE: 1:1
		DOCUMENT TYPE: Sales	REV: p
		REL LEVEL: Released	SHEET 13 OF 17

REV: PEO200

REV	DATE	DESCRIPTION	ECO	BY	C.H.K.
P	2019-08-13 01:00:00 EDT	Y45L/UBH ADDED TO SHEET 48	51969	YR	SS

CATALOG NUMBER	STRANDED COPPER CONDUCTOR ACCOMMODATED			BOLT SIZE	METRIC BOLT SIZE	DIMENSIONS							
	CODE (AWG)	NAVY	METRIC SIZE (CLASS 2)			B	C	K DIA.	L	N	O.D.	T REF.	Z MIN.
YA35L	550 Kcmil	-----	-----	5/8	M16	1.69 [43]	1.65 [42]	.69 [18]	3.81 [97]	.66 [17]	1.13 [29]	.25 [06]	.67 [17]
YA36L11 YA36L11UNPL	600 Kcmil	↑	300mm² STR [23.1]	1/2	M12	1.38 [35]	1.74 [44]	.53 [13]	3.29 [84]	.53 [13]	1.19 [30]	.27 [17]	.55 [14]
YA36L				5/8	M16	1.38 [35]	1.74 [44]	.69 [18]	3.54 [90]	.66 [17]	1.19 [30]	.67 [17]	
YA36L1				3/4	----	1.38 [35]	1.74 [44]	.81 [21]	3.72 [94]	.75 [19]	1.19 [30]	.77 [20]	
YA36L2				1/2	M12	1.38 [35]	1.74 [44]	.53 [13]	3.29 [84]	.53 [13]	1.19 [30]	.55 [14]	
YA36LTC78				7/8	----	1.38 [35]	1.74 [44]	.94 [24]	3.97 [101]	.88 [22]	1.19 [30]	.89 [23]	
YA37L				650 Kcmil	-----	-----	5/8	M16	1.39 [35]	1.80 [46]	.69 [18]	3.57 [91]	.66 [17]
YA37L1	650 Kcmil	-----	-----	3/4	----	1.39 [35]	1.80 [46]	.81 [21]	3.76 [96]	.75 [19]	1.23 [31]	.77 [20]	
YA38L	700 Kcmil	-----	-----	5/8	M16	1.45 [37]	1.84 [47]	.69 [18]	3.66 [93]	.66 [17]	1.25 [32]	.27 [17]	.67 [17]

CONNECTOR SIZE	TOLERANCES					
	B	C	K DIA.	L	N	O.D.
-8C THRU -25	±.06	±.04	±.02	±.09	±.03	±.01
-26 THRU -34	±.08	±.04	±.02	±.12	±.03	±.01
-35 AND UP	±.09	±.06	±.02	±.15	±.06	±.01

TOLERANCE BLOCK

CATALOG NO.	COLOR CODE	DIE INFORMATION		MECHANICAL RATCHET				HYDRAULIC						DIELESS (# CRIMPS)	WIRE STRIP LENGTH	
		DIE INDEX	TYPE	YIMRTC	OUR840	MD6 MD7	MD6--R2 MD7-34R	Y500CT PATMD6 PAT600	Y34A Y34B Y34BH	Y35, Y39 Y750, PAT750	Y46 PAT46	Y45	Y48B			Y60BHU
YA35L	YELLOW	21	YELLOW DIE SET NEST INDENTOR	----	----	----	----	----	----	U35RT(2)	U35RT(2)	U35RT(2)	----	L35RT(1)	HYDRAULIC: Y644 (1) Y81KFT (2) Y4PC834 (2)	1-3/4"
YA36L11 YA36L11UNPL YA36L YA36L1 YA36L2 YA36LTC78	GREEN	22 472	GREEN DIE SET NEST INDENTOR	----	----	----	----	----	----	U36RT(2) U32ART(2)	U36RT(2) U32ART(2)	U36RT(2) U32ART(2)	C36R(1) C32AR(1)	L36RT(1) L32ART(1)		
YA37L YA37L1	ORANGE	23	ORANGE DIE SET NEST INDENTOR	----	----	----	----	----	----	U37RT(2)	U37RT(2)	U37RT(2)	C37R(1)	L37RT(1)	HYDRAULIC: Y644 (1) Y81KFT (3) Y4PC834 (3)	1-15/16"
YA38L	PINK	400	PINK DIE SET NEST INDENTOR	----	----	----	----	----	----	U38RT(2)	U38RT(2)	U38RT(2)	----	L38RT(1)		

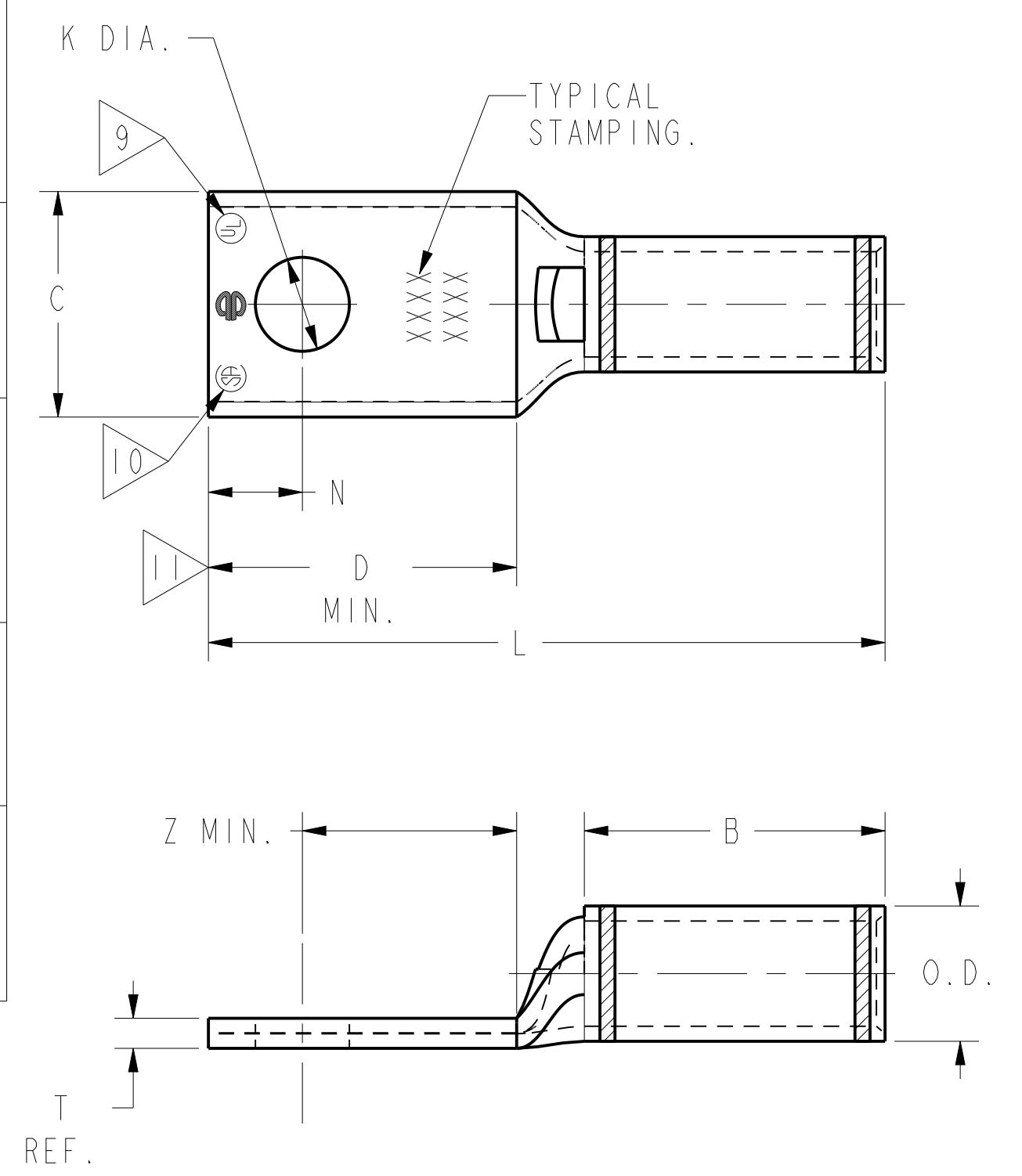

NOTES:

- MATERIAL: COPPER TUBING.
- FINISH: TIN PLATED.
"FOR ALTERNATIVE FINISH ADD ONE OF THE FOLLOWING SUFFIXES:
NICKEL = NK, LEAD = LD, BARE = BR, SILVER = SV"
- CATALOG # PT6515 ADAPTOR IS REQUIRED TO USE "U" DIES IN Y45 SERIES TOOLS.
- CATALOG # PUADP-1 ADAPTOR IS REQUIRED TO USE "U" DIES IN Y46 SERIES TOOLS.
- REMOVED PER PCN 2145.
- PERMANENT DIE IN TOOLING.
- DIMENSIONS IN BRACKETS [] ARE IN MILLIMETERS ROUNDED OFF TO THE NEAREST MILLIMETER, UNLESS OTHERWISE NOTED, AND ARE FOR REFERENCE ONLY.
- FOR USE BY CUSTOMERS THAT HAVE THIS HYPRESS™. NO NEW Y34A HYPRESS™ TOOLS ARE BEING PROCESSED. Y34A USES A--D NEST DIES ONLY.

- CONNECTORS ARE UL LISTED; UNDRILLED VERSIONS ARE NOT UL LISTED.
- CONNECTORS ARE CSA CERTIFIED. UNDRILLED VERSIONS ARE NOT CSA CERTIFIED.
- FOR UNDRILLED VERSIONS ADD SUFFIX "-U" TO END OF CATALOG NUMBER. FOR UNDRILLED VERSIONS, USE D MIN. = N MAX. + Z MIN.
- "X", "W-RT", "W-VT", "U" & "L" DIE SETS ARE COLOR CODED. "A", "B" AND "C" DIES ARE NOT COLOR CODED. NESTS AND INDENTOR TYPE ARE NOT COLOR CODED.
- ADD SUFFIX "UNPL" FOR UNPLATED CONNECTORS WITH NO BARREL MARKINGS.

REFERENCE: SE209240

TO ORDER BURNDY® PRODUCTS CALL		COPPER HYLUG™	
UNITED STATES 1-800-346-4175 (LONDONDERRY, NH)		ITEM NO: N/A	CAT. NO: YA-L-, YAV- (TABLE)
CANADA: 1-800-361-6975 (QUEBEC) 1-800-387-6487 (ALL OTHER PROVINCES)		DRAWN BY: J MICHAUD 8/17/94	CHECKER: D FILLION 10/3/94
FOR PRODUCT INFO: http://www.burndy.com		DSN APPVL: C PALAGI 8/19/94	MFG APPVL: N/A N/A
		QA APPVL: C ACKERMAN 9/30/94	MKT APPVL: T NELSON 9/7/94
		PROD FAM: CM&R COMPRESSION	DRAWING NO: REV
		PROJECT #: --	SIZE: SD079848
		DOCUMENT TYPE: Sales	SHEET 14 OF 17
		REL LEVEL: Released	D

REV: PEO200

REV	DATE	DESCRIPTION	ECO	BY	C.H.K.
P	2019-08-13 01:00:00 EDT	Y45L/100H ADDED TO SHEET 10	51969	YR	SS

CATALOG NUMBER	STRANDED COPPER CONDUCTOR ACCOMMODATED			BOLT SIZE	METRIC BOLT SIZE	DIMENSIONS							
	CODE (AWG)	NAVY	METRIC SIZE (CLASS 2)			B	C	K DIA	L	N	O.D.	T REF.	Z MIN.
YA39L YA39LUNPL	750 Kcmil	↑ ↓	375mm ² STR	5/8	M16	1.42 [36]	1.91 [49]	.69 [18]	3.57 [93]	.66 [17]	1.30 [33]	.27 [7]	.67 [17]
YA39L2				7/8	----	↑	↑	.94 [24]	4.10 [104]	.88 [22]	↑	↑	.89 [23]
YA39L9				1-1/4	----	↓	↓	1.31 [33]	4.85 [123]	1.25 [32]	↓	↓	1.27 [32]
YA39L6				1/2	M12	1.42 [36]	1.91 [49]	.53 [13]	3.41 [87]	.53 [13]	1.30 [33]	.27 [7]	.55 [14]
YA40L				800 Kcmil	400mm ² STR [26.1]	5/8	M16	1.42 [36]	1.98 [50]	.69 [18]	3.81 [97]	.66 [17]	1.35 [34]
YA41L	850 Kcmil	-----	-----	5/8	M16	1.88 [48]	2.01 [51]	.69 [18]	4.15 [105]	.66 [17]	1.38 [8]	.31 [8]	.67 [17]

CONNECTOR SIZE	TOLERANCES					
	B	C	K DIA.	L	N	O.D.
-8C THRU -25	±.06	±.04	±.02	±.09	±.03	±.01
-26 THRU -34	±.08	±.04	±.02	±.12	±.03	±.01
-35 AND UP	±.09	±.06	±.02	±.15	±.06	±.01

TOLERANCE BLOCK

CATALOG NO.	COLOR CODE	INSTALLATION TOOLING (# CRIMPS)														DIELESS (# CRIMPS)	WIRE STRIP LENGTH
		DIE INFORMATION		MECHANICAL RATCHET				HYDRAULIC									
		DIE INDEX	TYPE	YIMRTC	OUR840	MD6 MD7	MD6--R2 MD7-34R	Y500CT PATMD6 PAT600	Y34A Y34B Y34BH	Y35, Y39 Y750, PAT750	Y46 PAT46	Y45	Y48B	Y60BHU			
YA39L YA39LUNPL YA39L2 YA39L9 YA39L6	BLACK	24	BLACK DIE SET	----	----	----	----	----	----	U39RT(2)	U39RT(2) P39RT(2)	U39RT(2) S39RT(2)	C39R(1) C36AR(1)	L39RT(1) L36ART(1)	HYDRAULIC: Y644 (1) Y81KFT (3) Y4PC834 (3)	1-15/16"	
			NEST	----	----	----	----	----	----		P39D(1)		C39D(1)				
			INDENTOR								P44PR		Y48PR				
YA40L	ORANGE	25	ORANGE DIE SET	----	----	----	----	----	----		P40RT(3)	S40RT(3)	C40R(1)	L40RT(1)	HYDRAULIC: Y644 (1) Y81KFT (3) Y4PC834 (3)	1-15/16"	
			NEST	----	----	----	----	----	----		P40D(1)		C40D(1)				
			INDENTOR								P44PR		Y48PR				
YA41L	GOLD	26	GOLD DIE SET	----	----	----	----	----	----						HYDRAULIC: Y644 (1) Y81KFT (3) Y4PC834 (3)	1-15/16"	
			NEST	----	----	----	----	----	----		P41D(1)		C41D(1)				
			INDENTOR								P44PR		Y48PR				

- NOTES:
- MATERIAL: COPPER TUBING.
 - FINISH: TIN PLATED.
"FOR ALTERNATIVE FINISH ADD ONE OF THE FOLLOWING SUFFIXES:
NICKEL = NK, LEAD = LD, BARE = BR, SILVER = SV"
 - CATALOG # PT6515 ADAPTOR IS REQUIRED TO USE "U" DIES IN Y45 SERIES TOOLS.
 - CATALOG # PUADP-1 ADAPTOR IS REQUIRED TO USE "U" DIES IN Y46 SERIES TOOLS.
 - PERMANENT DIE IN TOOLING.
 - DIMENSIONS IN BRACKETS [] ARE IN MILLIMETERS ROUNDED OFF TO THE NEAREST MILLIMETER, UNLESS OTHERWISE NOTED, AND ARE FOR REFERENCE ONLY.
 - FOR USE BY CUSTOMERS THAT HAVE THIS HYPRESS™. NO NEW Y34A HYPRESS™ TOOLS ARE BEING PROCESSED. Y34A USES A--D NEST DIES ONLY.
 - CONNECTORS ARE UL LISTED; UNDRILLED VERSIONS ARE NOT UL LISTED.
 - CONNECTORS ARE CSA CERTIFIED. UNDRILLED VERSIONS ARE NOT CSA CERTIFIED.
 - FOR UNDRILLED VERSIONS ADD SUFFIX "-U" TO END OF CATALOG NUMBER.
FOR UNDRILLED VERSIONS, USE D MIN. = N MAX. + Z MIN.
 - "X", "W-RT", "W-VT", "U" & "L" DIE SETS ARE COLOR CODED. "A", "B" AND "C" DIES ARE NOT COLOR CODED. NESTS AND INDENTOR TYPE ARE NOT COLOR CODED.
 - ADD SUFFIX "UNPL" FOR UNPLATED CONNECTORS WITH NO BARREL MARKINGS.

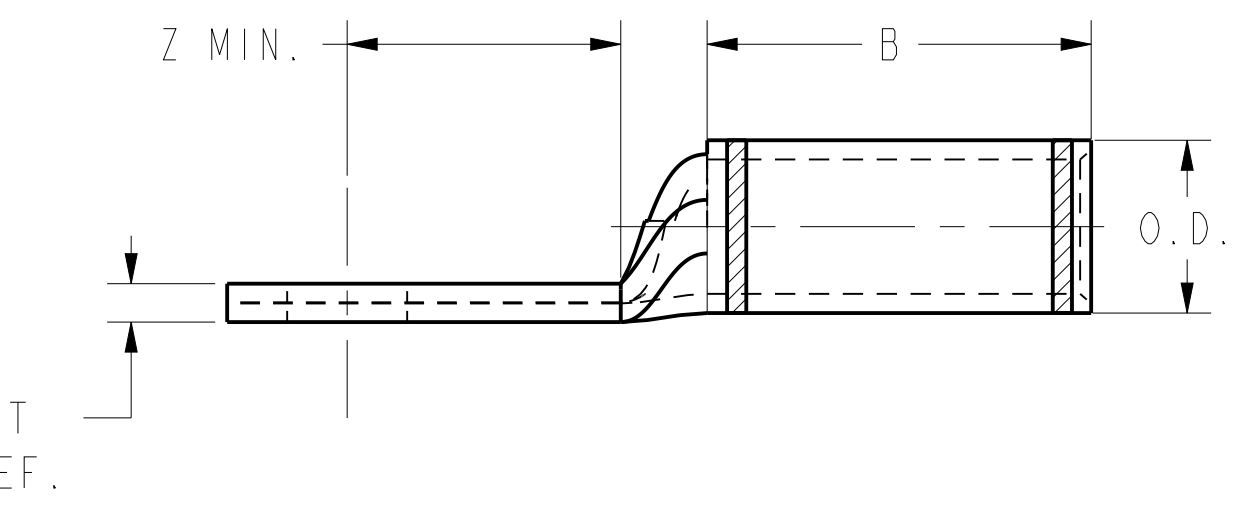
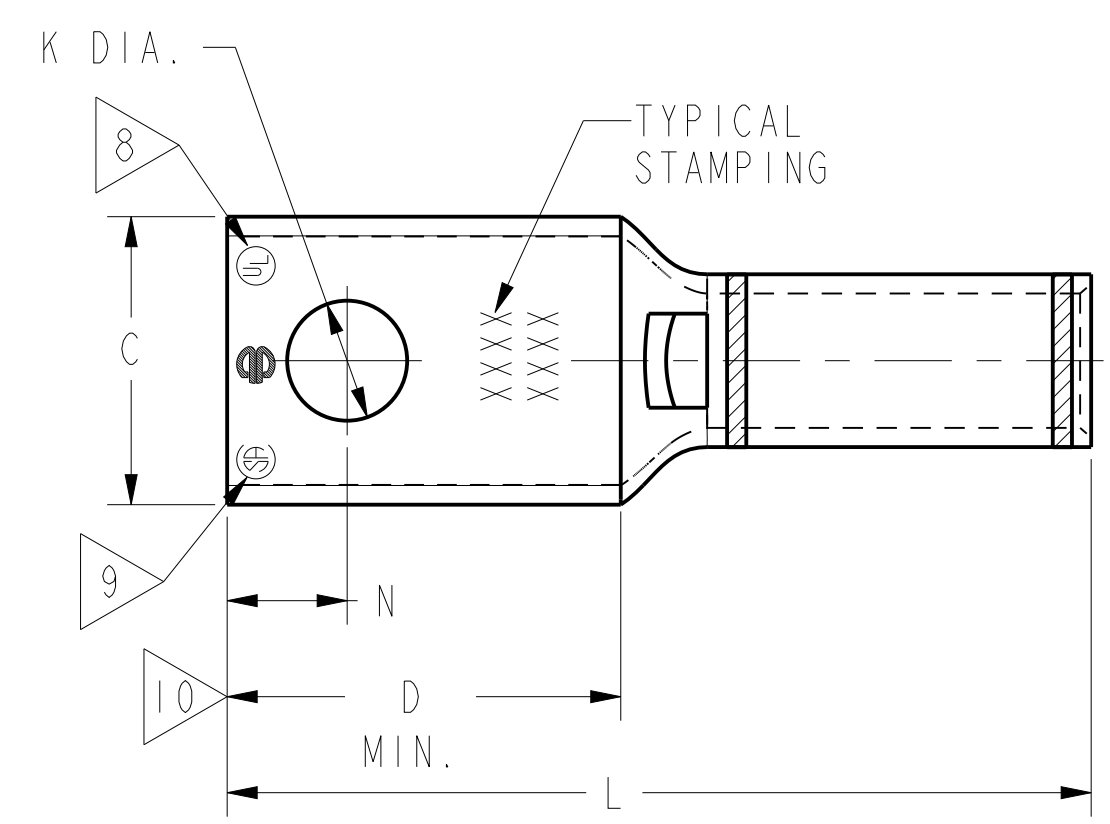

REFERENCE: SE209240

TO ORDER BURNDY® PRODUCTS CALL		COPPER HYLUG™	
UNITED STATES 1-800-346-4175 (LONDONDERRY, NH)		ITEM NO: N/A	CAT. NO: YA-L, YA-L-TC-, YAV-TC-
CANADA: 1-800-361-6975 (QUEBEC) 1-800-387-6487 (ALL OTHER PROVINCES)		DRAWN BY: J MICHAUD 8/17/94	CHECKER: D FILLION 10/3/94
FOR PRODUCT INFO: http://www.burndy.com		DSN APPVL: C PALAGI 8/19/94	MFG APPVL: N/A N/A
		QA APPVL: C ACKERMAN 9/30/94	MKT APPVL: T NELSON 9/7/94
		PROD FAM: CM&R COMPRESSION	DRAWING NO: SD079848
		PROJECT #: --	SCALE: 1:1
		DOCUMENT TYPE: Sales	REV: P
		REL LEVEL: Released	SHEET 15 OF 17

REV: PE0200

REV	DATE	DESCRIPTION	ECO	BY	C.H.K.
P	2019-08-13 01:00:00 EDT	Y45L10H ADDED TO SHEET 08	51969	YR	SS

CATALOG NUMBER	STRANDED COPPER CONDUCTOR ACCOMMODATED			BOLT SIZE	METRIC BOLT SIZE	DIMENSIONS							
	CODE (AWG)	NAVY	METRIC SIZE (CLASS 2)			B	C	K DIA.	L	N	O.D.	T REF.	Z MIN.
YA44L	1000 Kcmil	-----	-----	5/8	M16	1.65 [42]	2.19 [56]	.69 [18]	4.04 [103]	.66 [17]	1.50 [38]	.33 [8]	.67 [17]
YA44L2	1000 Kcmil	-----	-----	1/2	M12	1.65 [42]	2.19 [56]	.56 [14]	3.98 [101]	.63 [16]	1.50 [38]	.33 [8]	.64 [16]
YA44L23	1000 Kcmil	-----	-----	1	----	1.65 [42]	2.19 [56]	1.06 [27]	4.73 [120]	1.00 [25]	1.50 [38]	.33 [8]	1.02 [26]
YA45L	1250 Kcmil	-----	630mm ² STR [32.2]	3/4	----	2.00 [51]	2.46 [62]	.81 [21]	4.68 [119]	.75 [19]	1.69 [43]	.38 [10]	.77 [20]
YA45L12	1250 Kcmil	-----	630mm ² STR [32.2]	1/2	M12	2.00 [51]	2.46 [62]	.56 [14]	4.43 [113]	.63 [16]	1.69 [43]	.38 [10]	.64 [16]
YA453L	1300 Kcmil	-----	-----	3/4	----	2.00 [51]	2.53 [64]	.81 [21]	4.71 [120]	.75 [19]	1.74 [44]	.39 [10]	.77 [20]

CONNECTOR SIZE	TOLERANCES					
	B	C	K DIA.	L	N	O.D.
-8C THRU -25	±.06	±.04	±.02	±.09	±.03	±.01
-26 THRU -34	±.08	±.04	±.02	±.12	±.03	±.01
-35 AND UP	±.09	±.06	±.02	±.15	±.06	±.01

TOLERANCE BLOCK

CATALOG NO.	COLOR CODE	INSTALLATION TOOLING (# CRIMPS)														DIELESS (# CRIMPS)	WIRE STRIP LENGTH
		DIE INFORMATION				MECHANICAL				HYDRAULIC							
		DIE INDEX	TYPE	YIMRTC	OUR840	MD6 MD7	MD6--R2 MD7-34R	Y500CT PATMD6 PAT600	Y34A Y34B Y34BH	Y35, Y39 Y750, PAT750	Y46 PAT46	Y45	Y48B	Y60BHU			
YA44L YA44L2 YA44L23	WHITE	27	WHITE DIE SET NEST INDENTOR	----	----	----	----	----	----	----	P44RT(3) P44D(1) P44PR	S44RT(3)	C44R(1) C44D(1) Y48PR	L44RT(2)	HYDRAULIC: Y644 (1) Y81KFT (3) Y4PC834 (3)	1-15/16"	
YA45L YA45L12	YELLOW	29	YELLOW DIE SET NEST INDENTOR	----	----	----	----	----	----	----	P45RT(3) P45D(1) P44PR	S45RT(3)	C45R(2) C45D(1) Y48PR	L45RT(2)	----	2-1/16"	
YA53L	ORANGE	30	ORANGE DIE SET NEST INDENTOR	----	----	----	----	----	----	----	----	----	----	C453D(1) Y48PR	----	2-1/16"	

NOTES:

- MATERIAL: COPPER TUBING.
- FINISH: TIN PLATED.
"FOR ALTERNATIVE FINISH ADD ONE OF THE FOLLOWING SUFFIXES:
NICKEL = NK, LEAD = LD, BARE = BR, SILVER = SV"
- CATALOG # PT6515 ADAPTOR IS REQUIRED TO USE "U" DIES IN Y45 SERIES TOOLS.
- CATALOG # PUADP-1 ADAPTOR IS REQUIRED TO USE "U" DIES IN Y46 SERIES TOOLS.
- PERMANENT DIE IN TOOLING.
- DIMENSIONS IN BRACKETS [] ARE IN MILLIMETERS ROUNDED OFF TO THE NEAREST MILLIMETER, UNLESS OTHERWISE NOTED, AND ARE FOR REFERENCE ONLY.
- FOR USE BY CUSTOMERS THAT HAVE THIS HYPRESS™. NO NEW Y34A HYPRESS™ TOOLS ARE BEING PROCESSED. Y34A USES A--D NEST DIES ONLY.
- CONNECTORS ARE UL LISTED; UNDRILLED VERSIONS ARE NOT UL LISTED.
- CONNECTORS ARE CSA CERTIFIED; UNDRILLED VERSIONS ARE NOT CSA CERTIFIED.
- FOR UNDRILLED VERSIONS ADD SUFFIX "-U" TO END OF CATALOG NUMBER.
FOR UNDRILLED VERSIONS, USE D MIN. = N MAX. + Z MIN.
- "X", "W-RT", "W-VT", "U" & "L" DIE SETS ARE COLOR CODED. "A", "B" AND "C" DIES ARE NOT COLOR CODED. NESTS AND INDENTOR TYPE ARE NOT COLOR CODED.

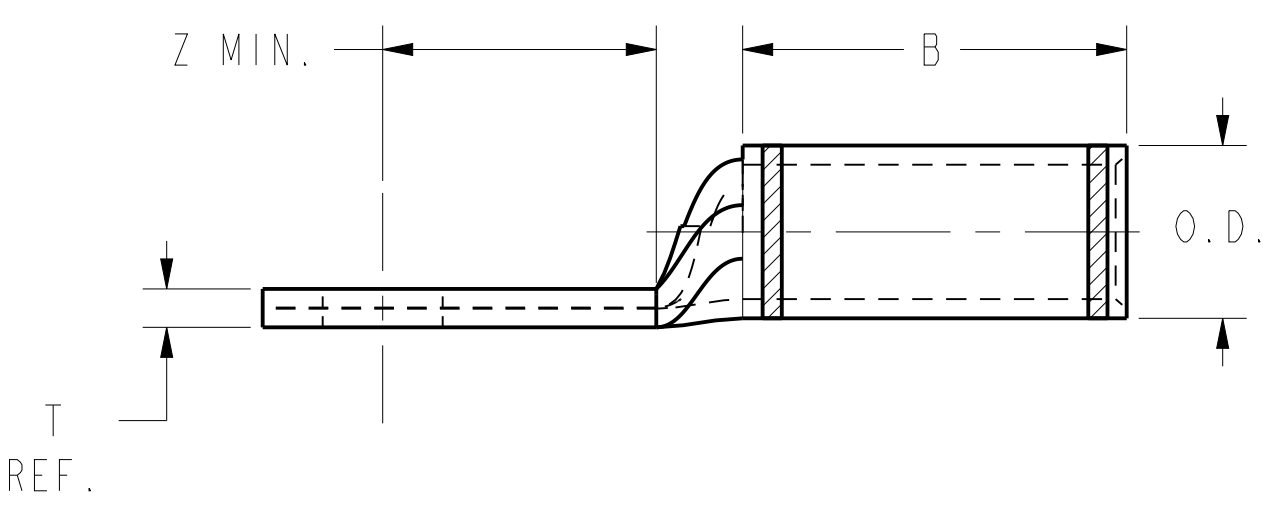
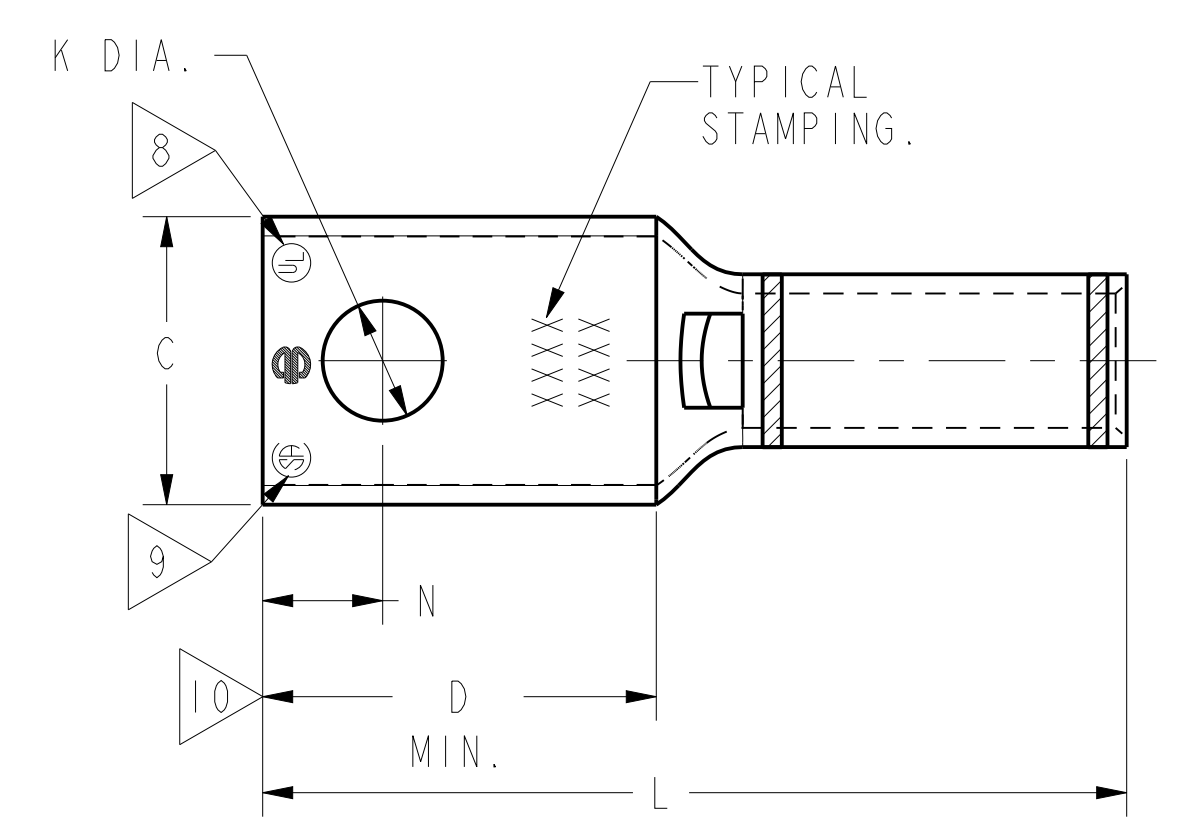

REFERENCE: SE209240

TO ORDER BURNDY® PRODUCTS CALL		HYLUG™ COPPER	
UNITED STATES 1-800-346-4175 (LONDONDERRY, NH)		ITEM NO: N/A	CAT. NO: YA-L, YA-L-TC & YAV-TC
CANADA: 1-800-361-6975 (QUEBEC) 1-800-387-6487 (ALL OTHER PROVINCES)		DRAWN BY: J MICHAUD 8/17/94	CHECKER: D FILLION 10/3/94
FOR PRODUCT INFO: http://www.burndy.com		DSN APPVL: C PALAGI 8/19/94	MFG APPVL: N/A N/A
		QA APPVL: C ACKERMAN 9/30/94	MKT APPVL: T NELSON 9/7/94
		PROD FAM: CM&R COMPRESSION	DRAWING NO: SD079848
		PROJECT #: --	SCALE: 1:1
		DOCUMENT TYPE: Sales	REV: P
		REL LEVEL: Released	SHEET 16 OF 17

REV: PEO200

REV	DATE	DESCRIPTION	ECO	BY	C.H.K.
P	2019-08-13 01:00:00 EDT	Y425L/808 ADDED TO SHEET 88	51969	YR	SS

CATALOG NUMBER	STRANDED COPPER CONDUCTOR ACCOMMODATED			BOLT SIZE	METRIC BOLT SIZE	DIMENSIONS							
	CODE (AWG)	NAVY	METRIC SIZE (CLASS 2)			B	C	K DIA.	L	N	O.D.	T REF.	Z MIN.
YA46L	1500 Kcmil	----	800mm ² STR [37.6]	3/4	----	2.00 [51]	2.69 [68]	.81 [21]	4.78 [121]	.75 [19]	1.84 [47]	.40 [10]	.77 [20]
YA47L	1750 Kcmil	----	----	3/4	----	2.19 [57]	2.90 [74]	.81 [21]	5.05 [128]	.75 [19]	1.98 [50]	.42 [11]	.77 [20]
YA48L	2000 Kcmil (1.632 DIA.)	----	1000mm ² STR [42.2]	3/4	----	2.25 [57]	3.10 [79]	.81 [21]	5.19 [132]	.75 [19]	2.13 [54]	.46 [12]	.77 [20]

CONNECTOR SIZE	TOLERANCES					
	B	C	K DIA.	L	N	O.D.
-8C THRU -25	±.06	±.04	±.02	±.09	±.03	±.01
-26 THRU -34	±.08	±.04	±.02	±.12	±.03	±.01
-35 AND UP	±.09	±.06	±.02	±.15	±.06	±.01

TOLERANCE BLOCK

CATALOG NO.	COLOR CODE	INSTALLATION TOOLING (# CRIMPS)																	
		DIE INFORMATION		MECHANICAL RATCHET				HYDRAULIC						DIELESS (# CRIMPS)	WIRE STRIP LENGTH				
DIE INDEX	TYPE	YIMRTC	OUR840	MD6 MD7	MD6--R2 MD7-34R	Y500CT PATMD6 PAT600	Y34A Y34B Y34BH	Y35, Y39 Y750, PAT750	Y46 PAT46	Y45	Y48B	Y60BHU							
YA46L	GREEN	31	GREEN DIE SET	----	----	----	----	----	----	----	P46RT(3)	S46RT(3)	C46R(2)	L46RT(2)	----	2-1/16"			
			NEST	----	----	----	----	----	----	----	----	----	----	----			C46D(1)	----	
			INDENTOR	----	----	----	----	----	----	----	----	----	----	----			----	Y48PR	----
YA47L	GRAY	33	GRAY DIE SET	----	----	----	----	----	----	----	----	----	----	C47R(2)	L47RT(2)	----	2-1/4"		
			NEST	----	----	----	----	----	----	----	----	----	----	----	C47D(1)			----	
			INDENTOR	----	----	----	----	----	----	----	----	----	----	----	----			Y48PR	----
YA48L	BROWN	34	BROWN DIE SET	----	----	----	----	----	----	----	----	----	----	----	L48RT(3)	----	2-3/8"		
			NEST	----	----	----	----	----	----	----	----	----	----	----	----			C48D(1)	----
			INDENTOR	----	----	----	----	----	----	----	----	----	----	----	----			Y48PR	----

- NOTES:**
- MATERIAL: COPPER TUBING.
 - FINISH: TIN PLATED.
"FOR ALTERNATIVE FINISH ADD ONE OF THE FOLLOWING SUFFIXES:
NICKEL = NK, LEAD = LD, BARE = BR, SILVER = SV"
 - CATALOG # PT6515 ADAPTOR IS REQUIRED TO USE "U" DIES IN Y45 SERIES TOOLS.
 - CATALOG # PUADP-1 ADAPTOR IS REQUIRED TO USE "U" DIES IN Y46 SERIES TOOLS.
 - PERMANENT DIE IN TOOLING.
 - DIMENSIONS IN BRACKETS [] ARE IN MILLIMETERS ROUNDED OFF TO THE NEAREST MILLIMETER, UNLESS OTHERWISE NOTED, AND ARE FOR REFERENCE ONLY.
 - FOR USE BY CUSTOMERS THAT HAVE THIS HYPRESS™. NO NEW Y34A HYPRESS™ TOOLS ARE BEING PROCESSED. Y34A USES A--D NEST DIES ONLY.
 - CONNECTORS ARE UL LISTED; UNDRILLED VERSIONS ARE NOT UL LISTED.
 - CONNECTORS ARE CSA CERTIFIED; UNDRILLED VERSIONS ARE NOT CSA CERTIFIED.
 - FOR UNDRILLED VERSIONS ADD SUFFIX "-U" TO END OF CATALOG NUMBER.
FOR UNDRILLED VERSIONS, USE D MIN. = N MAX. + Z MIN.
 - "X", "W-RT", "W-VT", "U" & "L" DIE SETS ARE COLOR CODED. "A", "B" AND "C" DIES ARE NOT COLOR CODED. NESTS AND INDENTOR TYPE ARE NOT COLOR CODED.
 - INDENTOR ONLY - NO NEST REQUIRED.

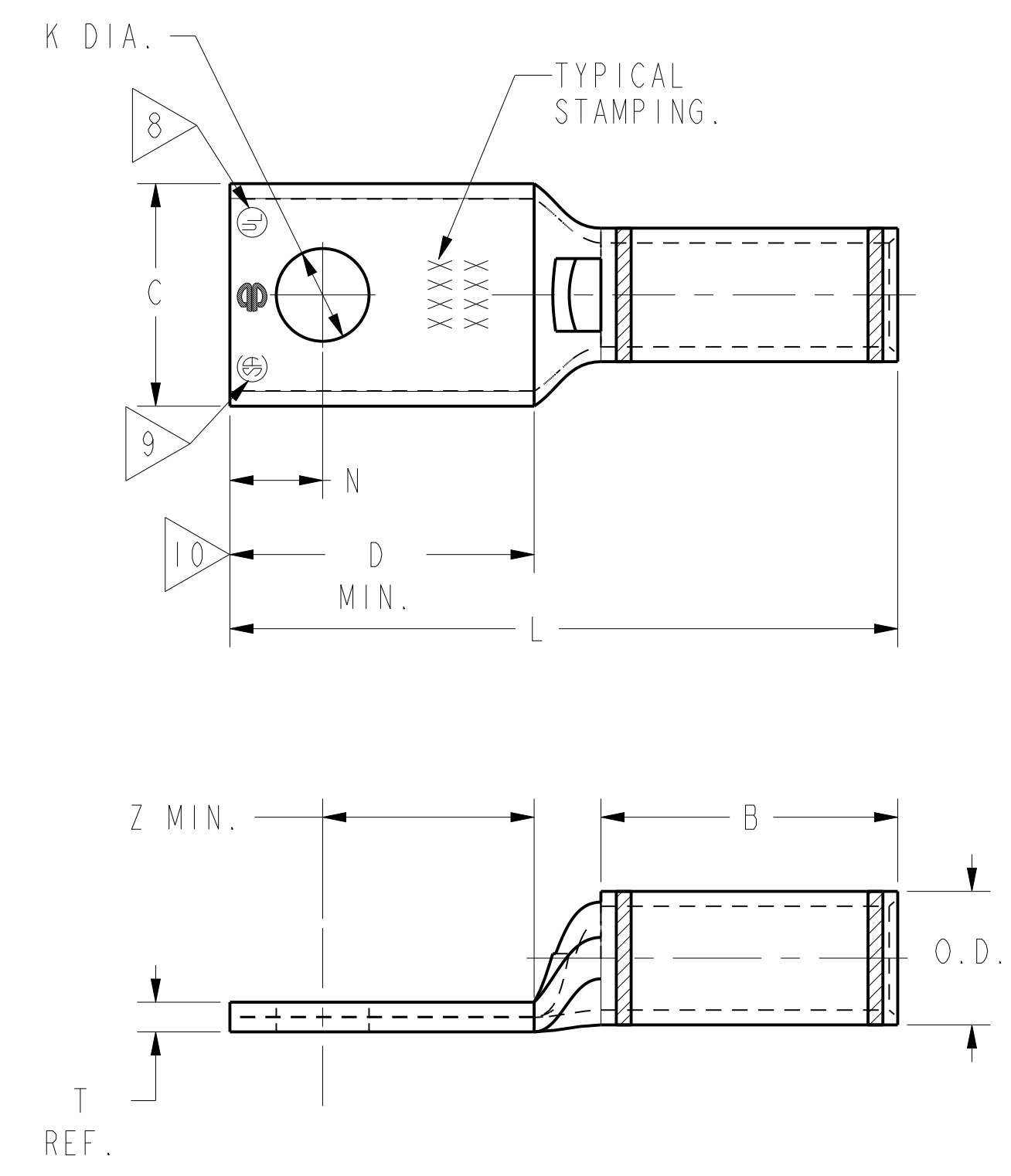

REFERENCE: SE209240

TO ORDER BURNDY® PRODUCTS CALL		COPPER HYLUG™	
UNITED STATES 1-800-346-4175 (LONDONDERRY, NH)		ITEM NO: N/A	CAT. NO: YA-L, YA-L-TC-, YAV-TC-
CANADA: 1-800-361-6975 (QUEBEC) 1-800-387-6487 (ALL OTHER PROVINCES)		DRAWN BY: J MICHAUD 8/17/94	CHECKER: D FILLION 10/3/94
FOR PRODUCT INFO: http://www.burndy.com		DSN APPVL: C PALAGI 8/19/94	MFG APPVL: N/A N/A
		QA APPVL: C ACKERMAN 9/30/94	MKT APPVL: T NELSON 9/7/94
		PROD FAM: CM&R COMPRESSION	DRAWING NO: SD079848
		PROJECT #: --	SCALE: 1:1
		DOCUMENT TYPE: Sales	REV: P
		REL LEVEL: Released	SHEET 17 OF 17

REV: PE0200