

# Section 23

## Relays and Timers



### General Purpose Relays 23-2

Zelio™ RSL Interface Relays	23-2
Zelio™ RSB Interface Relays	23-3
Zelio™ RXG Interface Relays	23-4
Zelio™ RXM Plug-In Relays	23-6
Zelio™ RPM Plug-In Relays	23-9
Zelio™ RUM Plug-In Relays	23-11
Zelio™ RPF Power Relays	23-13
792 Ice Cube Relays	23-14
781R / 782 / 783 / 784 Plug-in Relays	23-16
750R Series Universal Relays	23-24
788R Series Universal Relays	23-27
199 Power Relays	23-48
725 Power Relays	23-51
389F Power Relays	23-53
300 Power Relays	23-56
92 Power Relays	23-58
Square D™ Universal Relays	23-60
Square D™ Plug-in Relays	23-62
Square D™ Miniature Control Relays	23-63
Square D™ Power Relays	23-65
750H Hazardous Location Series	23-66

### Solid State Relays 23-68

861H Solid-State Relays	23-68
Zelio™ SSL Relays	23-70
Zelio™ SSM Relays	23-71
Zelio™ SSL, SSM and SSP	23-73
6000 Solid-State Relays	23-79
SSRDIN Solid-State Relays	23-81
861 Solid-State Relays	23-83
70S2 Solid-State Relays	23-85

### Industrial Relays 23-87

TeSys™ D IEC Style Instantaneous Control Relays	23-87
TeSys™ K IEC Style Control Relays	23-90
TeSys™ SK IEC Style Control Relays	23-93
Square D™ NEMA Style AC Relays	23-94
Square D™ NEMA Style DC Relays	23-96

### Timers 23-100

Zelio™ RE17, E22 and RENF22 Modular Timers	23-100
Zelio™ RE48 Panel Mount Timers	23-102
Zelio™ REXL Miniature Plug-In Timers	23-103
820 Series Time Delay and Sensor Relays	23-104
TDR782 Series Time Delay and Sensor Relays	23-105
TDRPRO Series Time Delay and Sensor Relays	23-107
Square D™ JCK General Purpose Plug-In Timers	23-109

### Control and Measurement Relays 23-111

Zelio™ Current Measurement Relays	23-111
Zelio™ Phase Measurement Relays	23-112
Zelio™ Voltage Measurement Relays	23-113

### Power Supplies 23-117

### Interface Modules 23-118



RSL 1PV\*\*



RSL 1PR\*\*



RSL 1AB\*\*



RSL ZVA\*



RSL ZRA\*



RSL Z2



RSL Z3

### Zelio™ RSL Interface Relays

Zelio RSL slim interface relays save valuable panel space with a 6 mm width and have a 6 A general purpose load rating. Features include:

- Pre-assembled option: relay and socket are combined into one catalog number.
- Universal AC/DC sockets have built-in protection from transients and reverse polarity voltages (see catalog DIA3ED2090304EN-US for more detailed information).
- Accessories, which include isolators, ID tags, and bus jumper save valuable installation time.
- SPDT (1 C/O) design

Refer to [Online EZ Selector](#).

**Table 23.1: Pre-assembled Relay and Socket Combination (sold in lots of 10)**

Socket Supply Voltage	Pre-Assembled Catalog Number <sup>[1]</sup>		Replacement Relays Catalog Number
	Screw Connector	Spring Terminal	
12 Vac/Vdc	<a href="#">RSL1PVJU</a>	<a href="#">RSL1PRJU</a>	RSL1AB4JD
24 Vac/Vdc	<a href="#">RSL1PVBU</a>	<a href="#">RSL1PRBU</a>	RSL1AB4BD
48 Vac/Vdc	<a href="#">RSL1PVEU</a>	<a href="#">RSL1PREU</a>	RSL1AB4ED
110 Vac/Vdc	<a href="#">RSL1PVFU</a>	<a href="#">RSL1PRFU</a>	RSL1AB4ND
230 Vdc	<a href="#">RSL1PVPU</a>	<a href="#">RSL1PRPU</a>	RSL1AB4ND

**Table 23.2: Relays (sold in lots of 10)**

Relay Coil Voltage <sup>[2]</sup>	Catalog Number
12 Vdc	<a href="#">RSL1AB4JD</a>
24 Vdc	<a href="#">RSL1AB4BD</a>
48 Vdc	<a href="#">RSL1AB4ED</a>
60 Vdc	<a href="#">RSL1AB4ND</a>

**Table 23.3: Sockets (sold in lots of 10)**

Control Voltage	Socket Type		For Use with Relays:
	Screw Connector	Spring Terminal	
	Catalog Number	Catalog Number	
12 Vac/Vdc	<a href="#">RSLZVA1</a>	<a href="#">RSLZRA1</a>	RSL1AB4JD
24 Vac/Vdc		<a href="#">RSLZRA1</a>	RSL1AB4BD
48 Vac/Vdc	<a href="#">RSLZVA2</a>	<a href="#">RSLZRA2</a>	RSL1AB4ED
60 Vac/Vdc			RSL1AB4ND
110 Vac/Vdc	<a href="#">RSLZVA3</a>	<a href="#">RSLZRA3</a>	RSL1AB4ND
230 Vac/Vdc	<a href="#">RSLZVA4</a>	<a href="#">RSLZRA4</a>	RSL1AB4ND

**Table 23.4: Accessories**

Description	Compatibility	Catalog Number
ID tags (2 sheets of 64 tags)	With all RSL and SSL series sockets	<a href="#">RSLZ5</a>
Bus jumper (10 x 20-pole jumpers)		<a href="#">RSLZ2</a>
Butterfly isolator (10 isolators)		<a href="#">RSLZ3</a>

### Approvals for RSL Relays



File: E173076  
CCN: NRNT2, NRNT8



File: 240278  
Class: 3211 04



IEC 61810-1

RoHS Compliant

### Approvals for RSLZ Sockets



File: E172326  
CCN: SWIV2, SWIV8



File: 254977  
Class: 3211 07



IEC 61984

RoHS Compliant

[1] Relays are mounted on sockets equipped with LED and protection circuit.

[2] The RSL sockets will accept an AC or DC input voltage; however, the relay always receives a filtered DC voltage.

### Zelio™ RSB Interface Relays

Zelio RSB interface relays and sockets provide the optimum combination of robust performance and space saving for the most demanding applications. Relays are rated at 8 A, 12 A, and 16 A (250 Vac / 28 Vdc). Features include:

- Optional protection modules for protection against electrical transients
- Optional plastic hold-down ejector clips
- Socket or printed circuit board installation options

Refer to [Online EZ Selector](#).



RSB1A160F7



RSB2A080BD



RSZE1S48M



RSB1A120JD Relay  
+ RZM031FPD Socket  
+ RSZE1S35M Module



RSB1A160BD Relay  
+ RSZE1S48M Socket

Table 23.5: Relays (sold in lots of 10)

Coil Voltage	Number and type of contacts - Thermal current (Ith)		
	SPDT (1 C/O) -12 A Res.	SPDT (1 C/O) -16 A Res.	DPDT (2 C/O) -8 A Res.
	Catalog Number <sup>[3]</sup>	Catalog Number <sup>[3]</sup>	Catalog Number <sup>[3]</sup>
6 Vdc	RSB1A120RD	RSB1A160RD	RSB2A080RD
12 Vdc	RSB1A120JD	RSB1A160JD	RSB2A080JD
24 Vdc	RSB1A120BD	RSB1A160BD	RSB2A080BD
48 Vdc	RSB1A120ED	RSB1A160ED	RSB2A080ED
60 Vdc	RSB1A120ND	RSB1A160ND	RSB2A080ND
110 Vdc	RSB1A120FD	RSB1A160FD	RSB2A080FD
24 Vac	RSB1A120B7	RSB1A160B7	RSB2A080B7
48 Vac	RSB1A120E7	RSB1A160E7	RSB2A080E7
120 Vac	RSB1A120F7	RSB1A160F7	RSB2A080F7
220 Vac	RSB1A120M7	RSB1A160M7	RSB2A080M7
230 Vac	RSB1A120P7	RSB1A160P7	RSB2A080P7
240 Vac	RSB1A120U7	RSB1A160U7	RSB2A080U7

Table 23.6: Sockets – 12 A, 300 Vac (sold in lots of 10)

Contact Terminal Arrangement	Connection	For Use with Relays	Catalog Number
Separate <sup>[4]</sup>	Box lug connector	RSB1A120**	RSZE1S35M
		RSB1A160** <sup>[5]</sup>	RSZE1S48M
		RSB2A080**	

Table 23.7: Protection Modules (sold in lots of 10)

Description	Compatibility	Voltage	Catalog Number
Diode	RSZ***** sockets (RSB series), RGZ***** sockets (RXG series)	6–230 Vdc	RZM040W
RC circuit		24–60 Vac	RZM041BN7
		110–240 Vac	RZM041FU7
Diode + green LED	6–24 Vdc	RZM031RB	
	24–60 Vdc	RZM031BN	
Varistor + green LED	110–230 Vdc	RZM031FPD	
	6–24 Vac/Vdc	RZM021RB	
	24–60 Vac/Vdc	RZM021BN	
		110–230 Vac/Vdc	RZM021FP

Table 23.8: Accessories (sold in lots of 10)

Description	Compatibility	Catalog Number
Plastic hold-down ejector clip	RSZ***** sockets (RSB series)	RSZR215
ID tags		RSZL300

#### Approvals for RSB Relays

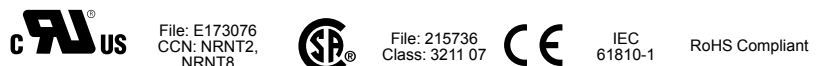

#### Approvals for RSZ Sockets

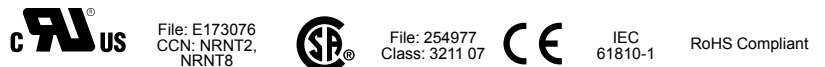

- RZM modules are RoHS compliant.
- For mounting track, see [Mounting Track, End Clamps, Jumpers, Fanning Strips, page](#)

<sup>[3]</sup> To order a relay complete with socket (sold in lots of 20): add suffix S to the catalog numbers selected above.  
Example: RSB 2A080RD + RSZ E1S48M becomes RSB 2A080RDS.  
<sup>[4]</sup> The inputs and outputs are on separate sides.  
<sup>[5]</sup> When using the RSB1A160\*\* relay with socket RSZ E1S48M, terminals 11 and 21, 14 and 24, 12 and 22 must be linked.

New!

**Zelio™ RXG Interface Relays**

The Zelio RXG interface relay range is comprised of 10 A relays with 1 C/O contact and 5 A relays with 2 C/O contacts all in the same optimal foot print. The mating sockets feature separate contact terminals with reliable screw connections that attach either to a convenient 35 mm DIN rail or flexible panel mounting. The entire offer is a complete system solution with protection modules (diode, diode + LED, RC circuit, or varistor + LED), plastic ejector/maintaining clip and ID Tags to identify relays.

- Standard hold-down ejector clip integrated with socket
- Optional protection modules for protection against electrical transients
- Industry standard footprint for seamless compatibility with competitive sockets
- UL Listed combination (Relay + Socket) for expedited system certification

Refer to [Online EZ Selector](#).



RGZE1S35M Socket + RXG12BD Relay



RXG11RD



RXG22B7



RXG13RD



RXG15RD

**Table 23.9: Relays: Standard Cover, without LED, with Test Button and Lock-Down Door (sold in lots of 10)**

Coil Voltage	Number and type of contacts - Thermal current (Ith)	
	SPDT (1 C/O) - 10 A	DPDT (2 C/O) - 5 A
	Catalog Number	Catalog Number
6 Vdc	RXG11RD	RXG21RD
12 Vdc	RXG11JD	RXG21JD
24 Vdc	RXG11BD	RXG21BD
48 Vdc	RXG11ED	RXG21ED
60 Vdc	RXG11ND	RXG21ND
110 Vdc	RXG11FD	RXG21FD
24 Vac	RXG11B7	RXG21B7
48 Vac	RXG11E7	RXG21E7
120 Vac	RXG11F7	RXG21F7
220 Vac	RXG11M7	RXG21M7
230 Vac	RXG11P7	RXG21P7

**Table 23.10: Relays: Standard Cover, with LED, with Test Button and Lock-Down Door (sold in lots of 10)**

Coil Voltage	Number and type of contacts - Thermal current (Ith)	
	SPDT (1 C/O) - 10 A	DPDT (2 C/O) - 5 A
	Catalog Number	Catalog Number
6 Vdc	RXG12RD	RXG22RD
12 Vdc	RXG12JD	RXG22JD
24 Vdc	RXG12BD	RXG22BD
48 Vdc	RXG12ED	RXG22ED
60 Vdc	RXG12ND	RXG22ND
110 Vdc	RXG12FD	RXG22FD
24 Vac	RXG12B7	RXG22B7
48 Vac	RXG12E7	RXG22E7
120 Vac	RXG12F7	RXG22F7
220 Vac	RXG12M7	RXG22M7
230 Vac	RXG12P7	RXG22P7

**Table 23.11: Relays: Standard Cover, with LED, without Test Button and Lock-Down Door (sold in lots of 10)**

Coil Voltage	Number and type of contacts - Thermal current (Ith)	
	SPDT (1 C/O) - 10 A	DPDT (2 C/O) - 5 A
	Catalog Number	Catalog Number
6 Vdc	RXG13RD	RXG23RD
12 Vdc	RXG13JD	RXG23JD
24 Vdc	RXG13BD	RXG23BD
48 Vdc	RXG13ED	RXG23ED
60 Vdc	RXG13ND	RXG23ND
110 Vdc	RXG13FD	RXG23FD
24 Vac	RXG13B7	RXG23B7
48 Vac	RXG13E7	RXG23E7
120 Vac	RXG13F7	RXG23F7
220 Vac	RXG13M7	RXG23M7
230 Vac	RXG13P7	RXG23P7

**Table 23.12: Relays: Clear Cover, without LED, without Test Button and Lock-Down Door (sold in lots of 10)**

Coil Voltage	Number and type of contacts - Thermal current (Ith)	
	SPDT (1 C/O) - 10 A	DPDT (2 C/O) - 5 A
	Catalog Number	Catalog Number
6 Vdc	RXG15RD	RXG25RD
12 Vdc	RXG15JD	RXG25JD
24 Vdc	RXG15BD	RXG25BD
48 Vdc	RXG15ED	RXG25ED
60 Vdc	RXG15ND	RXG25ND
110 Vdc	RXG15FD	RXG25FD
24 Vac	RXG15B7	RXG25B7
48 Vac	RXG15E7	RXG25E7
120 Vac	RXG15F7	RXG25F7
220 Vac	RXG15M7	RXG25M7
230 Vac	RXG15P7	RXG25P7



RGZE1S48M



RZM031RB



RSZL300

**Table 23.13: Sockets (sold in lots of 10)**

Contact Terminal Arrangement	Connection	For Use with Relays	Catalog Number
Separate <sup>[6]</sup>	Box lug connector	RXG1***	<a href="#">RGZE1S35M<sup>[7]</sup></a>
		RXG2***	<a href="#">RGZE1S48M<sup>[7]</sup></a>

**Table 23.14: Protection Modules (sold in lots of 10)**

Description	Voltage	Compatibility	Catalog Number	
Diode	6 to 230 Vdc 24 to 60 Vac	RSZ***** sockets (RSB series), RGZ***** sockets (RXG series)	<a href="#">RZM040W</a>	
RC circuit	110 to 240 Vac		<a href="#">RZM041BN7</a>	
	6 to 24 Vdc		<a href="#">RZM041FU7</a>	
Diode + green LED	24 to 60 Vdc		<a href="#">RZM031RB</a>	
	110 to 230 Vdc		<a href="#">RZM031BN</a>	
Varistor + green LED	6 to 24 Vdc/Vac		<a href="#">RZM031FPD</a>	
	24 to 60 Vdc/Vac		<a href="#">RZM021RB</a>	
	110 to 230 Vdc/Vac		<a href="#">RZM021BN</a>	
				<a href="#">RZM021FP</a>

**Table 23.15: Accessories (sold in lots of 10)**

Description	For Use With	Catalog Number
Plastic ejector clip	RXG series (RSZ***** sockets)	<a href="#">RGZR215</a>
Socket ID tags		<a href="#">RSZL300</a>
Relay ID tags		<a href="#">RGZL520</a>

**Approvals for RXG Relays**



**Approvals for RGZ Sockets**



[6] The inputs and outputs are on separate sides.  
 [7] Please note that RGZE1S35M and RGZE1S48M sockets come standard with the RGZR215 ejector clip  
 [8] When used with the appropriate RGZ socket.



RXM4AB2BD + RXZE2S114M +  
RXZR335 + RXZL520



RXM2AB1B7



RXM2AB2BD



RXM2AB3F7

### Zelio™ RXM Plug-In Relays

Zelio RXM miniature plug-in relays and sockets provide a complete system solution in response to the most demanding applications ranging from 3 to 12 A. Some of the features include:

- Test button with removable lock-down door for testing the contacts (depending on model)
- Green LED indication of relay status (depending on model)
- Mechanical indication of relay status (standard)
- Optional protection modules to protect against electrical spikes
- Bus jumpers for connecting multiple terminals reduce installation time

[Online EZ Selector](#)

**Table 23.16: Relays: without LED, with Test button and Lock-Down Door (sold in lots of 10)**

Coil Voltage	Number and type of contacts - Thermal current (Ith)		
	DPDT (2 C/O) -12 A Res.	3PDT (3 C/O) - 10 A Res.	4PDT (4 C/O) - 8 A Res.
	Catalog Number	Catalog Number	Catalog Number
12 Vdc	RXM2AB1JD	RXM3AB1JD	RXM4AB1JD
24 Vdc	RXM2AB1BD	RXM3AB1BD	RXM4AB1BD
48 Vdc	RXM2AB1ED	RXM3AB1ED	RXM4AB1ED
110 Vdc	RXM2AB1FD	RXM3AB1FD	RXM4AB1FD
220 Vdc	—	—	RXM4AB1MD
24 Vac	RXM2AB1B7	RXM3AB1B7	RXM4AB1B7
48 Vac	RXM2AB1E7	RXM3AB1E7	RXM4AB1E7
120 Vac	RXM2AB1F7	RXM3AB1F7	RXM4AB1F7
230 Vac	RXM2AB1P7	RXM3AB1P7	—
240 Vac	—	—	RXM4AB1U7

**Table 23.17: Relays: with LED, with Test Button and Lock-Down Door (sold in lots of 10)**

Coil Voltage	Number and type of contacts - Thermal current (Ith)		
	DPDT (2 C/O) -12 A Res.	3PDT (3 C/O) - 10 A Res.	4PDT (4 C/O) - 8 A Res.
	Catalog Number	Catalog Number	Catalog Number
12 Vdc	RXM2AB2JD	RXM3AB2JD	RXM4AB2JD
24 Vdc	RXM2AB2BD	RXM3AB2BD	RXM4AB2BD
48 Vdc	RXM2AB2ED	RXM3AB2ED	RXM4AB2ED
110 Vdc	RXM2AB2FD	RXM3AB2FD	RXM4AB2FD
125 Vdc	—	—	RXM4AB2GD
24 Vac	RXM2AB2B7	RXM3AB2B7	RXM4AB2B7
48 Vac	RXM2AB2E7	RXM3AB2E7	RXM4AB2E7
120 Vac	RXM2AB2F7	RXM3AB2F7	RXM4AB2F7
230 Vac	RXM2AB2P7	RXM3AB2P7	RXM4AB2P7

**Table 23.18: Relays: with LED, without Test Button and Lock-Down Door (sold in lots of 10)**

Coil Voltage	Number and type of contacts - Thermal current (Ith)		
	DPDT (2 C/O) -12 A Res.	3PDT (3 C/O) - 10 A Res.	4PDT (4 C/O) - 8 A Res.
	Catalog Number	Catalog Number	Catalog Number
12 Vdc	RXM2AB3JD	—	RXM4AB3JD
24 Vdc	RXM2AB3BD	—	RXM4AB3BD
48 Vdc	RXM2AB3ED	—	RXM4AB3ED
110 Vdc	RXM2AB3FD	—	RXM4AB3FD
125 Vdc	—	—	RXM4AB3GD
24 Vac	RXM2AB3B7	—	RXM4AB3B7
48 Vac	RXM2AB3E7	—	RXM4AB3E7
120 Vac	RXM2AB3F7	—	RXM4AB3F7
230 Vac	RXM2AB3P7	—	RXM4AB3P7

**Table 23.19: Relays: Low level Contacts, without LED, with Test Button and Lock-Down Door (sold in lots of 10)**

Coil Voltage	Number and type of contacts - Thermal current (Ith)
	4PDT (4 C/O) -3 A Res.
	Catalog Number
12 Vdc	RXM4GB1JD
24 Vdc	RXM4GB1BD
48 Vdc	RXM4GB1ED
110 Vdc	RXM4GB1FD
24 Vac	RXM4GB1B7
48 Vac	RXM4GB1E7
120 Vac	RXM4GB1F7
230 Vac	RXM4GB1P7



RXM4GB2F7

**Table 23.20: Relays: Low Level Contacts, with LED, with Test button and Lock-Down Door (sold in lots of 10)**

Coil Voltage	Number and type of contacts - Thermal current (Ith)	
	4PDT (4 C/O) - 3 A Res.	
	Catalog Number	
12 Vdc		RXM4GB2JD
24 Vdc		RXM4GB2BD
48 Vdc		RXM4GB2ED
110 Vdc		RXM4GB2FD
24 Vac		RXM4GB2B7
48 Vac		RXM4GB2E7
120 Vac		RXM4GB2F7
230 Vac		RXM4GB2P7
240 Vac		RXM4GB2U7

**Table 23.21: Relays: Low Level Contacts, with LED, without Test Button and Lock-Down Door (sold in lots of 10)**

Coil Voltage	Number and type of contacts - Thermal current (Ith)	
	4PDT (4 C/O) - 3 A Res.	
	Catalog Number	
12 Vdc		RXM4GB3JD
24 Vdc		RXM4GB3BD
48 Vdc		RXM4GB3ED
110 Vdc		RXM4GB3FD
125 Vdc		—
24 Vac		RXM4GB3B7
48 Vac		RXM4GB3E7
120 Vac		RXM4GB3F7
230 Vac		RXM4GB3P7

- For sockets and accessories, see [page 23-8](#).



RXZE2S108M



RXM040W



RXZ400

Sockets and Accessories for Zelio™ RXM Relays

Refer to Online EZ Selector.

Table 23.22: Sockets (sold in lots of 10)

Contact Terminal Arrangement	Connection	For Use with Relays	Catalog Number
Mixed <sup>[9]</sup>	Screw clamp terminals	RXM2**** <sup>[10]</sup> RXM4**** <sup>[10]</sup>	RXZE2M114 <sup>[11]</sup>
	Box lug connector	RXM2**** RXM4****	RXZE2M114M <sup>[11]</sup>
Separate <sup>[12]</sup>	Box lug connector	RXM2****	RXZE2S108M <sup>[13]</sup>
		RXM3****	RXZE2S111M <sup>[11]</sup>
	Spring Terminal	RXM4**** RXM2****	RXZE2S114M RXZE2S114S

Table 23.23: Protection Modules (sold in lots of 10)

Description	Voltage	Compatibility	Catalog Number
Diode	6–250 Vdc	RXZ**** sockets (RXM series), RPZF1 and RPZF2 sockets (RPM series)	RXM040W
RC circuit	24–60 Vac		RXM041BN7
	110–240 Vac		RXM041FU7
Varistor	6–24 Vac/Vdc	RXM021RB	
	24–60 Vac/Vdc	RXM021BN	
	110–240 Vac/Vdc	RXM021FP	

Table 23.24: Accessories (sold in lots of 10)

Description	Compatibility	Catalog Number
Metal hold-down clip	RXZ sockets (RXM series)	RXZ400
Plastic hold-down ejector clip	RXZ sockets (RXM series)	RXZR335
Bus jumper, 2-pole (Ith: 5 A max. )	RXZE2S sockets (RXM series)	RXZS2
DIN rail mounting adapter <sup>[14]</sup>	RXM series relays, RPM1 and RPM2 series relays	RXZE2DA RXZE2FA
Relay ID tags (sheet of 108 tags)	RXM series relays, RPM series relays, RUM series relays	RXZL520
Socket ID tags	RXZ sockets (RXM series, except RXZE2M114), RUZS sockets (RUM series)	RXZL420

Approvals for RXM Relays



File: E164862  
CCN: NLDX,  
NLDX7<sup>[15]</sup>



File:  
E164862  
CCN:  
NLDX2,  
NLDX8



File:  
230765  
Class:  
3211 07



RoHS  
Compliant

Approvals for RXZ Sockets



File: E172326  
CCN: SWIV2,  
SWIV8



File: 230765  
Class: 3211 07



RoHS  
Compliant

[9] The inputs and outputs are mixed on both sides.  
 [10] When mounting relay RXM2\*\*\*\* on socket RXZE2M\*\*\*\*, the thermal current must not exceed 10 A.  
 [11] Thermal current Ith: 10 A  
 [12] The inputs and outputs are on separate sides.  
 [13] Thermal current Ith: 12 A  
 [14] Test button and lock-down door become inaccessible.  
 [15] When used with the appropriate RXZ socket.

### Zelio™ RPM Plug-In Relays

Zelio RPM plug-in relays and sockets provide a complete system solution for the most demanding applications up to 15 A. Some of the features include:

- Test button with removable lock-down door for testing the contacts (depending on model)
- Green LED indication of relay status (depending on model)
- Mechanical indication of relay status (standard)
- Optional modules to protect against electrical spikes

Refer to [Online EZ Selector](#).



RPZF4 Socket  
+RPM42P7 Relay



RPM13BD



RPM23P7



RPM33BD



RPM43BD

**Table 23.25: Relays: without LED, with Test Button and Lock-Down Door (sold in lots of 10)**

Coil Voltage	Number and type of contacts - Thermal current (Ith)			
	SPDT (1 C/O) - 15 A Res.	DPDT (2 C/O) - 15 A Res.	3PDT (3 C/O) - 15 A Res.	4PDT (4 C/O) - 15 A Res.
	Catalog Number	Catalog Number	Catalog Number	Catalog Number
12 Vdc	RPM11JD	RPM21JD	RPM31JD	RPM41JD
24 Vdc	RPM11BD	RPM21BD	RPM31BD	RPM41BD
48 Vdc	RPM11ED	RPM21ED	RPM31ED	RPM41ED
110 Vdc	RPM11FD	RPM21FD	RPM31FD	RPM41FD
24 Vac	RPM11B7	RPM21B7	RPM31B7	RPM41B7
48 Vac	RPM11E7	RPM21E7	RPM31E7	RPM41E7
120 Vac	RPM11F7	RPM21F7	RPM31F7	RPM41F7
230 Vac	RPM11P7	RPM21P7	RPM31P7	RPM41P7

**Table 23.26: Relays: with LED, with Test Button and Lock-Down Door (sold in lots of 10)**

Coil Voltage	Number and type of contacts - Thermal current (Ith)			
	SPDT (1 C/O) - 15 A Res.	DPDT (2 C/O) - 15 A Res.	3PDT (3 C/O) - 15 A Res.	4PDT (4 C/O) - 15 A Res.
	Catalog Number	Catalog Number	Catalog Number	Catalog Number
12 Vdc	RPM12JD	RPM22JD	RPM32JD	RPM42JD
24 Vdc	RPM12BD	RPM22BD	RPM32BD	RPM42BD
48 Vdc	RPM12ED	RPM22ED	RPM32ED	RPM42ED
110 Vdc	RPM12FD	RPM22FD	RPM32FD	RPM42FD
24 Vac	RPM12B7	RPM22B7	RPM32B7	RPM42B7
48 Vac	RPM12E7	RPM22E7	RPM32E7	RPM42E7
120 Vac	RPM12F7	RPM22F7	RPM32F7	RPM42F7
230 Vac	RPM12P7	RPM22P7	RPM32P7	RPM42P7

**Table 23.27: Relays: with LED, without Test Button and Lock-Down Door (sold in lots of 10)**

Coil Voltage	Number and type of contacts - Thermal current (Ith)			
	SPDT (1 C/O) - 15 A Res.	DPDT (2 C/O) - 15 A Res.	3PDT (3 C/O) - 15 A Res.	4PDT (4 C/O) - 15 A Res.
	Catalog Number	Catalog Number	Catalog Number	Catalog Number
12 Vdc	RPM13JD	RPM23JD	RPM33JD	RPM43JD
24 Vdc	RPM13BD	RPM23BD	RPM33BD	RPM43BD
48 Vdc	RPM13ED	RPM23ED	RPM33ED	RPM43ED
110 Vdc	RPM13FD	RPM23FD	RPM33FD	RPM43FD
125 Vdc	—	—	—	—
24 Vac	RPM13B7	RPM23B7	RPM33B7	RPM43B7
48 Vac	RPM13E7	RPM23E7	RPM33E7	RPM43E7
120 Vac	RPM13F7	RPM23F7	RPM33F7	RPM43F7
230 Vac	RPM13P7	RPM23P7	RPM33P7	RPM43P7



RPZF2



RXM041BN7



RUW241P7



RUW101MW



RPZ1DA



RPZ3FA

Sockets and Accessories for Zelio™ RPM Relays

Table 23.28: Sockets (sold in lots of 10)

Contact Terminal Arrangement	Connection	For Use with Relays	Catalog Number
Mixed <sup>[16]</sup>	Screw terminals	RPM1***	RPZF1
		RPM2***	RPZF2
		RPM3***	RPZF3
		RPM4***	RPZF4

Table 23.29: Protection Modules (sold in lots of 10)

Description	Voltage	Compatibility	Catalog Number
Diode	6–250 Vdc	RXZ sockets (RXM series), RPZF1, RPZF2	RXM040W
		RPZF3, RPZF4	RUW240BD
RC circuit	24–60 Vac	RXZ sockets (RXM series), RPZF1, RPZF2	RXM041BN7
	110–240 Vac		RXM041FU7
	110–240 Vac		RUW241P7
Varistor	6–24 Vac/Vdc	RXZ sockets (RXM series), RPZF1, RPZF2	RXM021RB
	24–60 Vac/Vdc		RXM021BN
	110–240 Vac/Vdc		RXM021FP
	24 Vac/Vdc		RUW242B7
	240 Vac/Vdc		RUW242P7

Table 23.30: Timer Module<sup>[17]</sup> (sold in lots of 1)

Description	Voltage	Compatibility	Catalog Number
On-delay timer, interval timer, repeat cycle timer/starting on-delay, repeat cycle timer/starting off-delay, off-delay timer, one-shot timer, timing on de-energization, on-delay timer	24–240 Vac/Vdc	RPZF3, RPZF4	RUW101MW

Table 23.31: Accessories (sold in lots of 10)

Description	Compatibility	Catalog Number
Metal hold-down clip (for single-pole relays)	RPZF1	RPZR235
DIN rail mounting adapter <sup>[18]</sup>	RPM1***	RPZ1DA
	RPM2***	RXZE2DA
	RPM3***	RPZ3DA
	RPM4***	RPZ4DA
Panel mounting adapter <sup>[18]</sup>	RPM1***	RPZ1FA
	RPM2***	RXZE2FA
	RPM3***	RPZ3FA
	RPM4***	RPZ4FA
ID tags (sheet of 108 tags)	RXM series relays, RPM series relays, RUM series relays	RXZL520

Approvals for RPM Relays



Approvals for RPZ Sockets

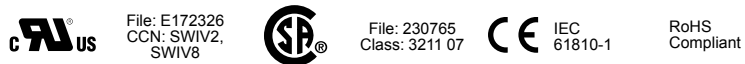

[16] The inputs and outputs are mixed on both sides.  
 [17] See timer module description (selection of functions and time delays) in catalog DIA3ED2090304EN-US.  
 [18] Test button and lock-down door become inaccessible  
 [19] When used with the appropriate RPZ socket.

New!

### Zelio™ RUM Plug-In Relays

Zelio RUM plug-in relays and sockets provide a complete system solution for the most demanding applications up to 10 A. Some of the features include:

- Test button with lock-down door for testing the contacts (depending on model)
- Green LED indication of relay status (depending on model)
- Mechanical indication of relay status (standard)
- Optional protection modules to protect against electrical spikes
- Bus jumpers for connecting multiple terminals reduce installation time.

Refer to [Online EZ Selector](#).



RUZSF3M Socket  
+ RUMF32BD Relay



RUMC31F7



RUMF22BD



RUMC23F7

**Table 23.32: Relays: without LED, with Test Button, and Lock-Down Door (sold in lots of 10)**

Pins	Coil Voltage	Number and type of contacts - Thermal current (Ith)	
		DPDT (2 C/O) -10 A Res.	3PDT (3 C/O) -10 A Res.
		Catalog Number	Catalog Number
Octal	12 Vdc	RUMC21JD	RUMC31JD
	24 Vdc	RUMC21BD	RUMC31BD
	48 Vdc	RUMC21ED	RUMC31ED
	60 Vdc	—	RUMC31ND
	110 Vdc	RUMC21FD	RUMC31FD
	125 Vdc	—	RUMC31GD
	220 Vdc	—	RUMC31MD
	24 Vac	RUMC21B7	RUMC31B7
	48 Vac	RUMC21E7	RUMC31E7
	120 Vac	RUMC21F7	RUMC31F7
Blade	230 Vac	RUMC21P7	RUMC31P7
	12 Vdc	RUMF21JD	RUMF31JD
	24 Vdc	RUMF21BD	RUMF31BD
	48 Vdc	RUMF21ED	RUMF31ED
	110 Vdc	RUMF21FD	RUMF31FD
	24 Vac	RUMF21B7	RUMF31B7
	48 Vac	RUMF21E7	RUMF31E7
	120 Vac	RUMF21F7	RUMF31F7
230 Vac	RUMF21P7	RUMF31P7	

**Table 23.33: Relays: with LED, Test Button, and Lock-Down Door (sold in lots of 10)**

Pins	Coil Voltage	Number and type of contacts - Thermal current (Ith)	
		DPDT (2 C/O) -10 A Res.	3PDT (3 C/O) -10 A Res.
		Catalog Number	Catalog Number
Octal	12 Vdc	RUMC22JD	RUMC32JD
	24 Vdc	RUMC22BD	RUMC32BD
	48 Vdc	RUMC22ED	RUMC32ED
	60 Vdc	—	RUMC32ND
	110 Vdc	RUMC22FD	RUMC32FD
	125 Vdc	—	RUMC32GD
	24 Vac	RUMC22B7	RUMC32B7
	48 Vac	RUMC22E7	RUMC32E7
	120 Vac	RUMC22F7	RUMC32F7
	230 Vac	RUMC22P7	RUMC32P7
Blade	12 Vdc	RUMF22JD	RUMF32JD
	24 Vdc	RUMF22BD	RUMF32BD
	48 Vdc	RUMF22ED	RUMF32ED
	110 Vdc	RUMF22FD	RUMF32FD
	24 Vac	RUMF22B7	RUMF32B7
	48 Vac	RUMF22E7	RUMF32E7
	120 Vac	RUMF22F7	RUMF32F7
	230 Vac	RUMF22P7	RUMF32P7

**Table 23.34: Relays: with LED, without Push Button, and Lock-Down Door (sold in lots of 10)**

Pins	Coil Voltage	Number and type of contacts - Thermal current (Ith)	
		DPDT (2 C/O) -10 A Res.	3PDT (3 C/O) -10 A Res.
		Catalog Number	Catalog Number
Octal	12 Vdc	RUMC23JD	RUMC33JD
	24 Vdc	RUMC23BD	RUMC33BD
	48 Vdc	RUMC23ED	RUMC33ED
	60 Vdc	—	RUMC33ND
	110 Vdc	RUMC23FD	RUMC33FD
	125 Vdc	—	RUMC33GD
	24 Vac	RUMC23B7	RUMC33B7
	48 Vac	RUMC23E7	RUMC33E7
	120 Vac	RUMC23F7	RUMC33F7
	230 Vac	RUMC23P7	RUMC33P7
Blade	12 Vdc	RUMF23JD	RUMF33JD
	24 Vdc	RUMF23BD	RUMF33BD
	48 Vdc	RUMF23ED	RUMF33ED
	110 Vdc	RUMF23FD	RUMF33FD
	125 Vdc	—	—
	24 Vac	RUMF23B7	RUMF33B7
	48 Vac	RUMF23E7	RUMF33E7
	120 Vac	RUMF23F7	RUMF33F7
230 Vac	RUMF23P7	RUMF33P7	



RUZC2M



RUW241P7



RUW101MW



RUZS2



RUZC200

### Sockets and Accessories for Zelio™ RUM Relays

Refer to [Online EZ Selector](#).

**Table 23.35: Sockets (sold in lots of 10)**

Contact Terminal Arrangement	Connection	For Use with Relays	Catalog Number
Mixed [20]	Box lug connector (screw terminals)	RUMC2****	RUZC2M
		RUMC3****	RUZC3M
		RUMC2****	RUZSC2M
RUMC3****		RUZSC3M	
Separate[21]		RUMF2****	RUZSF3M
		RUMF3****	

**Table 23.36: Protection Modules (sold in lots of 10)**

Description	Compatibility	Voltage	Catalog Number
Diode	RUZ... sockets (RUM series)	6–250 Vdc	RUW240BD
RC circuit		110–240 Vac	RUW241P7
Varistor		24 Vac/Vdc	RUW242B7
		240 Vac/Vdc	RUW242P7

**Table 23.37: Timer Module [22] (sold in lots of 1)**

Description	Compatibility	Voltage	Catalog Number
On-delay timer, interval timer, repeat cycle timer/starting on-delay, repeat cycle timer/starting off-delay, off-delay timer, one-shot timer, timing on de-energization, on-delay timer.	RUZ... sockets (RUM series)	24–240 Vac/Vdc	RUW101MW

**Table 23.38: Accessories (sold in lots of 10)**

Description	Compatibility	Catalog Number
Metal hold-down clip	RUZ sockets (RUM series)	RUZC200
Bus jumper, 2-pole (lth: 5 A)	RUZS sockets (RUM series)	RUZS2
Relay ID tags (sheet of 108 tags)	RXM series relays, RPM series relays, RUM series relays	RXZL520
Socket ID tags	RXZ sockets (RXM series, except RXZE2M114), RUZS sockets (RUM series),	RUZL420

#### Approvals for RUM Relays



File: E164862  
CCN: NLDX, NLDX7 [23]



File: E164862  
CCN: NLDX2, NLDX8



File: 230765  
Class: 3211 07



RoHS Compliant

#### Approvals for RUZ Sockets



File: E172326  
CCN: SWIV2, SWIV8



File: 230765  
Class: 3211 07



RoHS Compliant

[20] The inputs and outputs are mixed on both sides.

[21] The inputs and outputs are on separate sides.

[22] See timer module description (selection of functions and time delays) in catalog DIA3ED2090304EN-RUM-US.

[23] When used with the appropriate RUZ socket.



RPF2AP7



RPF2BBD

**Zelio™ RPF Power Relays**

Zelio RPF power relays respond to the most demanding applications up to 30 A. Features include:

- UL Listed
- Sealed construction
- Motor load ratings: 1 hp @ 120 Vac / 3 hp @ 240 Vac (N/O contacts only)
- DIN rail and panel mounting capability
- Short circuit rating of 5,000 A rms @ 3 hp, 240 Vac (N/O contacts only)

Refer to [Online EZ Selector](#).

**Table 23.39: Relays (sold in lots of 10)**

Coil Voltage	Number and type of contacts - Thermal current (Ith)	
	DPST (2 N/O) - 30 A at 277 Vac, 20 A at 28 Vdc	DPDT (2 C/O) - 30 A at 277 Vac, 20 A at 28 Vdc, 3A (NC)
	Catalog Number	Catalog Number
12 Vdc	<a href="#">RPF2AJD</a>	<a href="#">RPF2BJD</a>
24 Vdc	<a href="#">RPF2ABD</a>	<a href="#">RPF2BBD</a>
24 Vac	<a href="#">RPF2AB7</a>	<a href="#">RPF2BB7</a>
120 Vac	<a href="#">RPF2AF7</a>	<a href="#">RPF2BF7</a>
230 Vac	<a href="#">RPF2AP7</a>	<a href="#">RPF2BP7</a>

**Approvals for RPF Relays**



File: E43641  
CCN: NLDX, NLDX7



File: 040787  
Class: 3211-07



IEC 61810-1  
RoHS Compliant

- For mounting track (DIN rail), see [Mounting Track, End Clamps, Jumpers, Fanning Strips, page](#) .



**792 Ice Cube Relays**  
**DPDT 12 A; 4PDT 6 A and 3 A**

**Description**

The 792 plug-in control relays offer clear or full-feature covers with multiple mounting options and accessories. The 4PDT models save valuable space while adding increased functionality.



792 Clear Cover

792 Full-Feature Cover

Feature	Benefit
12 A / 6 A / 3 A switching current	Ideal choice for various automation panels and controls
Clear or full-feature cover options	Full-feature covers include an LED indicator and a locking test button to facilitate maintenance and speed up commissioning
DPDT and 4PDT contact options	Simultaneous control of 2 or 4 separate circuits
Socket-mounting option	Simplified installation and maintenance; use of protection modules, hold-down clips, and other accessories
Gold-flashed contacts	Reduced contact oxidation and increased shelf life
Mechanical flag indicator (standard)	Display of the status of an unpowered relay during testing or operation

Contact Rating	Contact Configuration	Nominal Coil Voltage	Coil Resistance (Ω)	Contacts	Part Number		
					Clear Cover	Clear Cover with LED	Full-Feature Cover
3 A	4PDT	12 Vac	44	Low-Level Bifurcated	792XDX3C12A	792XD3C12A	792XDX3M4L12A
		24 Vac	177		792XDX3C24A	792XD3C24A	792XDX3M4L24A
		48 Vac	708		792XD3C48A	792XD3C48A	792XDX3M4L48A
		120 Vac	3630		792XD3C120A	792XD3C120A	792XDX3M4L120A
		240 Vac	17720		792XD3C240A	792XD3C240A	792XDX3M4L240A
		12 Vdc	160		792XD3C12D	792XD3C12D	792XDX3M4L12D
		24 Vdc	640		792XD3C24D	792XD3C24D	792XDX3M4L24D
		48 Vdc	2560		792XD3C48D	792XD3C48D	792XDX3M4L48D
		110 Vdc	13440		792XD3C110D	792XD3C110D	792XDX3M4L110D
		12 A	DPDT		12 Vac	44	Standard
24 Vac	177			792XDX3C24A	—	792XDX3M4L24A	
48 Vac	708			792XDX3C48A	—	792XDX3M4L48A	
120 Vac	3630			792XDX3C120A	—	792XDX3M4L120A	
240 Vac	17720			792XDX3C240A	—	792XDX3M4L240A	
12 Vdc	160			792XDX3C12D	—	792XDX3M4L12D	
24 Vdc	640			792XDX3C24D	—	792XDX3M4L24D	
48 Vdc	2560			792XDX3C48D	—	792XDX3M4L48D	
110 Vdc	13440			792XDX3C110D	—	792XDX3M4L110D	
6 A	4PDT			12 Vac	44	Standard	
		24 Vac	177	792XDXC24A	792XD3C24A		792XDXM4L24A
		48 Vac	708	792XD3C48A	792XD3C48A		792XDXM4L48A
		120 Vac	3630	792XD3C120A	792XD3C120A		792XDXM4L120A
		240 Vac	17720	792XD3C240A	792XD3C240A		792XDXM4L240A
		12 Vdc	160	792XD3C12D	792XD3C12D		792XDXM4L12D
		24 Vdc	640	792XD3C24D	792XD3C24D		792XDXM4L24D
		48 Vdc	2560	792XD3C48D	792XD3C48D		792XDXM4L48D
		110 Vdc	13440	792XD3C110D	792XD3C110D		792XDXM4L110D

**Specifications**

Part Number	792XB3	792DX3	792DX3D	
<b>Contact Characteristics</b>				
Terminal Style	Blade	Blade	Blade	
Contact Material	Silver Alloy	Silver Alloy	Bifurcated	
Contact Configuration	DPDT	4PDT	4PDT	
Carrying Current	12 A	6 A	3 A	
Load Type	—	Standard	Low Level	
Maximum Switching Voltage	IEC: 250 Vac / 28 Vdc UL/CSA: 300 Vac / 30 Vdc	300 V	300 V	
Rated Switching Current (Conforming to IEC AC-1 and DC-1)	N.O.: 12 A at 250 Vac, N.C.: 6 A at 250 Vac	N.O.: 6 A; N.C.: 3 A	N.O.: 2 A; N.C.: 1 A	
	N.O.: 12 A at 28 Vdc, N.C.: 6 A at 28 Vdc	N.O.: 6 A; N.C.: 3 A	N.O.: 2 A; N.C.: 1 A	
Rated Switching Current (Conforming to UL)	General Purpose	—	3 A at 240–277 Vac	
	Resistive	12 A at 277 Vac, 100 k cycles	6 A at 277 Vac, 200 k cycles	3 A at 30 Vdc
		12 A at 120 Vac, 200 k cycles	8 A at 120 Vac, 200 k cycles	—
		12 A at 30 Vdc, 100 k cycles	8 A at 30 Vdc, 200 k cycles	—
	Motor	1/2 hp at 120 Vac, 6 k cycles	1/3 hp at 120 Vac, 6 k cycles	1/16 hp (2.8 A FLA) at 120 Vac
		1 hp at 277 Vac, 6 k cycles	1/2 hp at 277 Vac, 6 k cycles	—
B300 Pilot Duty	6 k cycles	—	—	
Pilot Duty	—	B300, 6 k cycles	5 A make, 0.5 A break, 3 A continuous at 120 Vac	
Minimum Switching Requirement	10 mA at 17 Vdc	10 mA at 17 Vdc	3 mA at 5 Vdc	
<b>Coil Characteristics</b>				
Maximum Operating Voltage	110% (AC/DC)	—	—	
Maximum Pickup Voltage	80% (AC/DC)	—	—	
Drop-out Voltage Threshold	15% (AC); 10% (DC)	—	—	
Average Consumption	0.9–1.2 VA (AC); 0.8–1.1 W (DC)	—	—	

**Dimensions, in. (mm)**

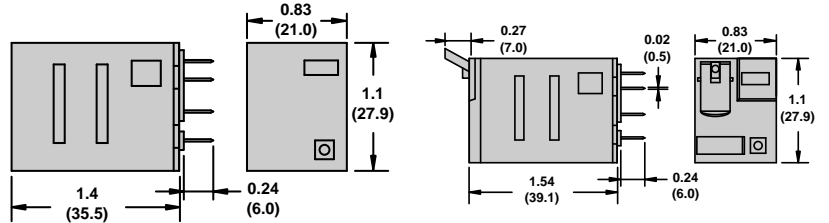

Clear Cover Dimension

Full-Feature Cover Dimension

**Wiring Diagrams**

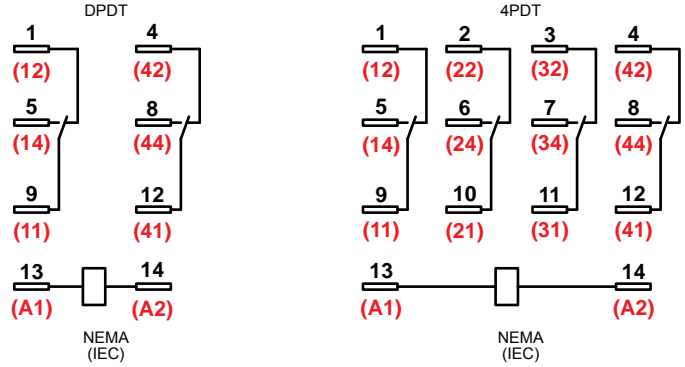

**Relay Accessories**

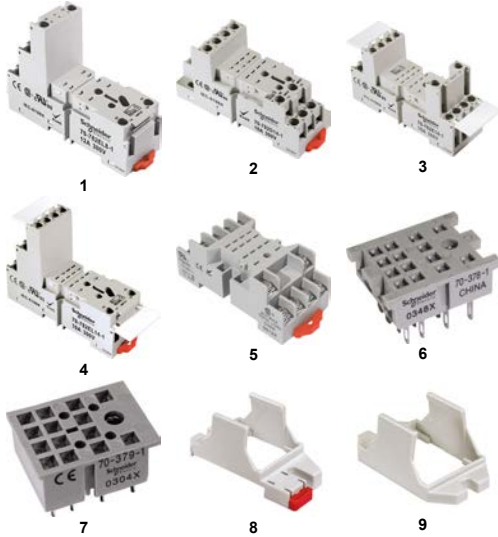

Description	Function	For Use with Relays	Pkg. Min.	Standard Part Number	
1	Socket	DIN or panel mounting with elevator terminals	792XB	10	70782EL81
2	Socket	DIN or panel mounting with screw terminals and clamping plates	792XB / 792XDX	10	70782D141
3	Socket	DIN or panel mounting with rising elevator box terminals		10	70782E141
4	Socket	DIN or panel mounting with elevator terminals		10	70782EL141
5	Socket	DIN or panel mounting with screw terminals and clamping plates		10	704611
6	Socket	Solder terminals for chassis mounting	792XDX	10	703781
7	Socket	Printed circuit terminals for PCB mounting	792XB / 792XDX	10	703791
8	Adapter	Direct DIN rail mounting		10	16782C
9	Adapter	Direct panel mounting		10	16782C1



Socket Accessories

Description	Function	For Use with Sockets	Coil Voltage	Pkg. Min.	Standard Part Number
1 Metal Spring Clip	Securing the relay in the socket	70-782D14-1, 70-782E14-1, 70-782EL14-1, 70-782EL8-1	—	10	16782SC
2 Plastic Hold-Down Clip	Securing the relay in the socket or ejecting the relay from the socket		—	10	16782PC1
3 Write-on Tag	Small write-on tag		—	10	16782FT1
4 Write-on Tag	Write-on tag for the 16-782PC-1 hold-down clip	—	—	10	16700ST1
5 Extruded Aluminum DIN Rail, 1 m (39.37 in.)	Quick installation and removal of sockets	70-782D14-1, 70-782E14-1, 70-782EL8-1, 70-782EL14-1	—	10	16700DIN
5 DIN Rail End Clip	Holding the sockets firmly in place on a DIN rail	—	—	10	16DCLIP1
6 Insulated Coil Bus Jumper System	Wireless socket connection	70-782EL8-1, 70-782EL14-1	—	10	16782CBJ1
<b>Small Socket Modules</b>					
Protection Diode	Protecting the external drive circuitry from inductive voltages	70-782D14-1, 70-782E14-1, 70-782EL14-1, 70-782EL8-1	6–250 Vdc	10	70BSMD250
7 LED Indicator	Providing coil status at a glance		24 Vac/Vdc	10	70BSMLG24
MOV Suppressor	Protection from damaging electrical spikes		120 Vac/Vdc	10	70BSMM120
			24 Vac/Vdc	10	70BSMM24
			240 Vac/Vdc	10	70BSMM240

NOTE: Using an LED socket module can increase the coil power draw by up to 10%.

781R / 782 / 783 / 784 Plug-in Relays

781R Series—SPDT 15A

Description

The 781R Series plug-in relays offer clear or full-feature covers with multiple mounting options and accessories.



UL Listed when used with corresponding sockets



781R Clear Cover

781R Full-Feature Cover

Feature	Benefit
15 A max . switching current	Ideal choice for automation control panels
14 mm width	Slim design to save valuable space
Clear or full-feature cover options	Full-feature covers include an LED indicator and a locking test button
Socket-mounting option	Simplified installation and maintenance; use of protection modules, hold-down clips, and other accessories
Gold-flashed contacts	Reduced contact oxidation and increased shelf life
Mechanical flag indicator (standard)	Display of the relay status during testing or operation

Contact Rating	Contact Configuration	Nominal Voltage	Coil Resistance (Ω)	Standard Part Number		
				Clear Cover	Clear Cover with LED	Full-Feature
15 A	SPDT	12 Vac, 50/60 Hz	44	781XAXRC12A	781XAXRCL12A	781XAXRM4L12A
		24 Vac, 50/60 Hz	177	781XAXRC24A	781XAXRCL24A	781XAXRM4L24A
		48 Vac, 50/60 Hz	708	781XAXRC48A	781XAXRCL48A	781XAXRM4L48A
		120 Vac, 50/60 Hz	4430	781XAXRC120A	781XAXRCL120A	781XAXRM4L120A
		240 Vac, 50/60 Hz	17720	781XAXRC240A	781XAXRCL240A	781XAXRM4L240A
		12 Vdc	115	781XAXRC12D	781XAXRCL12D	781XAXRM4L12D
		24 Vdc	450	781XAXRC24D	781XAXRCL24D	781XAXRM4L24D
		48 Vdc	1800	781XAXRC48D	781XAXRCL48D	781XAXRM4L48D
		110 Vdc	9460	781XAXRC110D	781XAXRCL110D	781XAXRM4L110D

**Specifications**

Part Number		781 / 782 / 783 / 784
<b>Contact Characteristics</b>		
Terminal Style	Blade	
Contact Material	Silver Alloy	
Contact Configuration	1CO / 2CO / 3CO / 4CO	
Carrying Current	15 A	
Maximum Switching Voltage	IEC: 250 Vac / 28 Vdc UL/CSA: 300 Vac / 28 Vdc	
Rated Switching Current at Voltage (Conforming to IEC AC-1 and DC-1)	at 250 Vac	N.O. : 15 A; N.C. : 7.5 A
	at 28 Vdc	N.O. : 15 A; N.C. : 7.5 A
Rated Switching Current (Conforming to UL)	Resistive	15 A at 277 Vac, 50/60 Hz, 100 k cycles 15 A at 28 Vdc, 100 k cycles
	Motor	1/2 hp at 120 Vac, 1 k cycles 1 hp at 277 Vac, 1 k cycles
	Pilot Duty	B3000
Minimum Switching Requirement	10 mA at 17 Vdc	
<b>Coil Characteristics</b>		
Maximum Operating Voltage	110% (AC/DC)	
Maximum Pickup Voltage	85% (AC/DC)	
Drop-out Voltage Threshold	15% (AC); 10% (DC)	
Average Consumption	Standard: 1.6 VA (AC); 1.1 W (DC) With LED: 1.9 VA (AC); 1.4 W (DC)	

**Dimensions, in. (mm)**

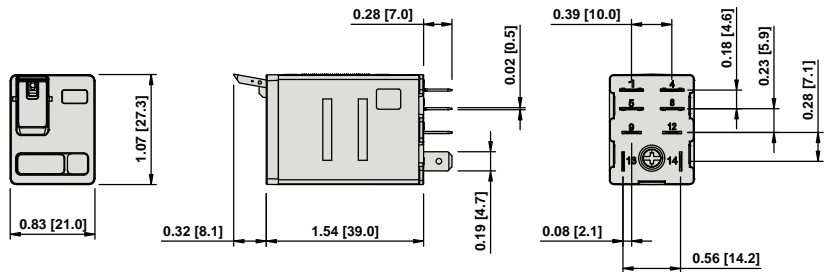
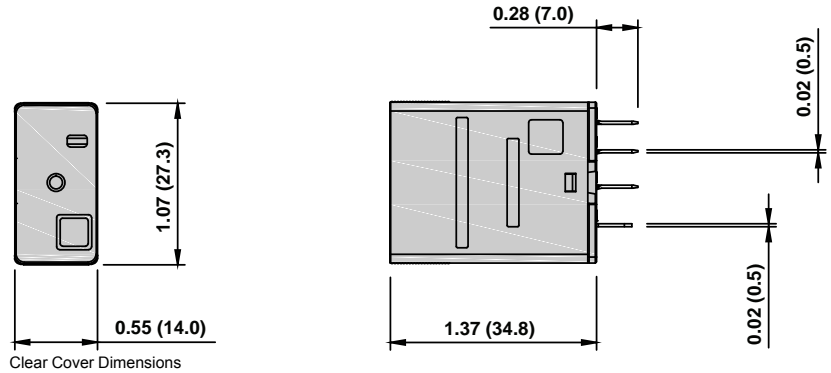

**Wiring Diagram**

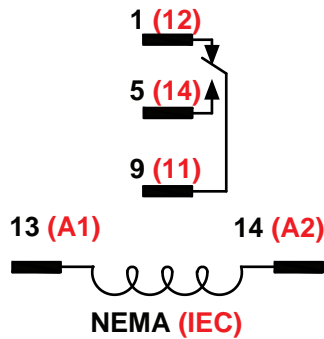

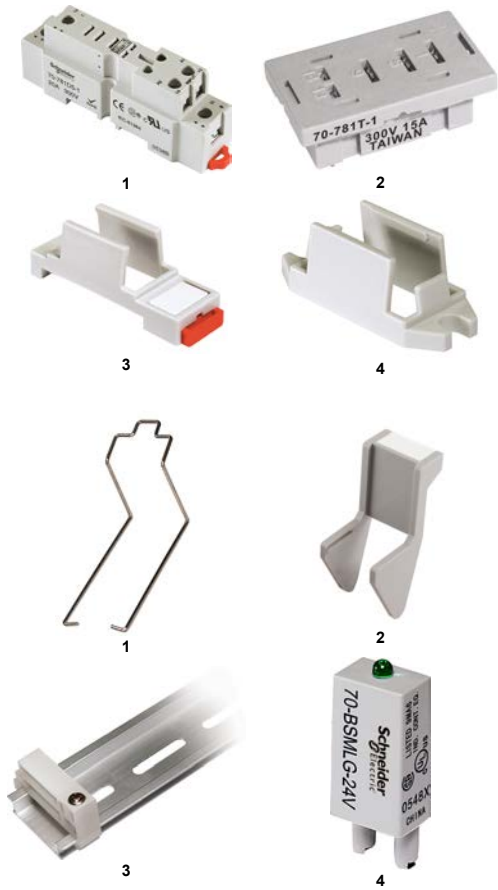

Relay Accessories

Description	Function	For Use with Relays	Pkg. Min.	Standard Part Number
1 Socket	DIN or panel mounting with screw terminals and clamping plates	781XAXR	10	70781D5R1A
2 Socket	PCB mounting		10	70781T1
3 Adapter	Direct DIN rail mounting		10	16781C
4 Adapter	Direct panel mounting		10	16781C1

Socket Accessories

Description	Function	For Use with Sockets	Coil Voltage	Pkg. Min.	Standard Part Number
1 Metal Spring Clip	Securing the relay in the socket	70781D5R1A, 70781T1	—	10	16781SC
2 Plastic ID Hold-Down Clip	Securing the relay in the socket and providing labeling	70781D5R1A	—	10	16781IDC
3 Extruded Aluminum DIN Rail, 1 m (39.37 in.)	Quick installation and removal of sockets		—	10	16700DIN
<b>Small Socket Modules</b>					
Protection Diode	Protecting the external drive circuitry from inductive voltages	70781D5R1A	6–250 Vdc	10	70BSMD250
4 LED Indicator	Providing coil status at a glance		24 Vac/Vdc	10	70BSMLG24
MOV Suppressor	Protection from damaging electrical spikes		120 Vac/Vdc	10	70BSMM120
			24 Vac/Vdc	10	70BSMM24
			240 Vac/Vdc	10	70BSMM240

NOTE: Using an LED socket module can increase the coil power draw by up to 10%.



**782 Power Series—DPDT 15 A**

Contact Rating	Contact Configuration	Nominal Voltage	Coil Resistance (Ω)	Standard Part Number			
				Clear Cover	Clear Cover with LED	PC Mount	Full-Feature
15 A	DPDT	6 Vac, 50/60 Hz	11	—	—	782XBXC6A	—
		12 Vac, 50/60 Hz	44	782XBXC12A	782XBXC12A	782XBXC12A	782BXM4L12A
		24 Vac, 50/60 Hz	177	782XBXC24A	782XBXC24A	782XBXC24A	782BXM4L24A
		48 Vac, 50/60 Hz	708	782XBXC48A	782XBXC48A	782XBXC48A	782BXM4L48A
		120 Vac, 50/60 Hz	4430	782XBXC120A	782XBXC120A	782XBXC120A	782BXM4L120A
		240 Vac, 50/60 Hz	17720	782XBXC240A	782XBXC240A	782XBXC240A	782BXM4L240A
		6 Vdc	40	—	—	782XBXC6D	—
		12 Vdc	160	782XBXC12D	782XBXC12D	782XBXC12D	782BXM4L12D
		24 Vdc	640	782XBXC24D	782XBXC24D	782XBXC24D	782BXM4L24D
		48 Vdc	2560	782XBXC48D	782XBXC48D	782XBXC48D	782BXM4L48D
110 Vdc	13440	782XBXC110D	782XBXC110D	782XBXC110D	782BXM4L110D		

**Dimensions, in. (mm)**

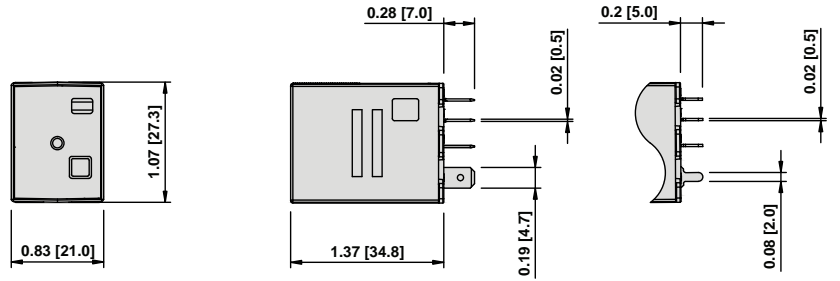

Clear Cover Dimensions

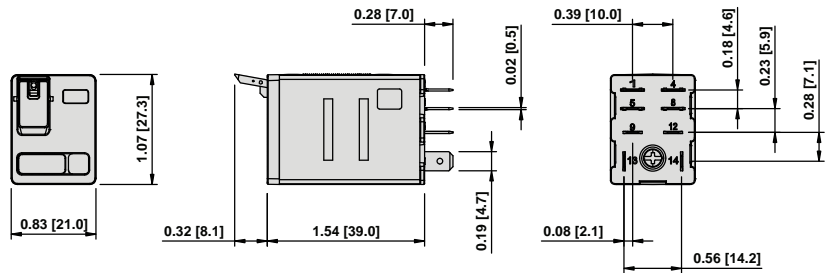

Full-Feature Cover Dimensions

**Wiring Diagram**

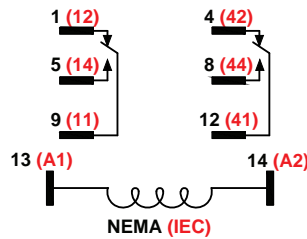

**Relay Accessories**

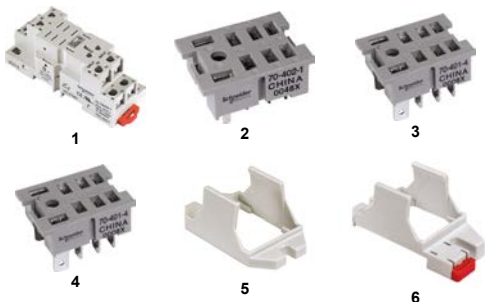

Description	Function	For Use with Relays	Pkg. Min.	Standard Part Number
1	Socket	DIN or panel mounting with screw terminals and clamping plates	10	70782D81A
2	Socket	DIN or panel mounting with screw terminals and clamping plates	10	704591
3	Socket	Quick Connect terminals for chassis mounting	10	704011
4	Socket	Printed circuit terminals for PCB mounting	10	704021
5	Adapter	Direct panel mounting	10	16782C1
6	Adapter	Direct DIN rail mounting	10	16782C



Socket Accessories

Description	Function	For Use with Sockets	Coil Voltage	Pkg. Min.	Standard Part Number
1, 2 Metal Spring Clip	Securing the relay in the socket	70782D81A, 704591, 704011, 704021	—	10	161342
3 Plastic Hold-Down Clip	Securing the relay in the socket, or ejecting the relay from the socket	70782D81A	—	10	16782PC1
4 Write-on Tag	Write-on tag for the 16782PC1 hold-down clip	—	—	10	16700ST1
5 Plastic ID Hold-Down Clip	Securing the relay in the socket and providing labeling	70782D81A, 704591, 704011, 704021	—	10	16782IDC
6 Extruded Aluminum DIN Rail, 1 m (39.37 in.)	Quick installation and removal of sockets	70782D81A, 704591	—	10	16700DIN
6 DIN Rail End Clip	Holding the sockets firmly in place on a DIN rail		—	10	16DCLIP1
<b>Small Socket Modules</b>					
Protection Diode	Protecting the external drive circuitry from inductive voltages	70782D81A	6–250 Vdc	10	70BSMD250
7 LED Indicator	Providing coil status at a glance		24 Vac/Vdc	10	70BSMLG24
MOV Suppressor	Protection from damaging electrical spikes		120 Vac/Vdc	10	70BSMM120
			24 Vac/Vdc	10	70BSMM24
			240 Vac/Vdc	10	70BSMM240

NOTE: Using an LED socket module can increase the coil power draw by up to 10%.

Refer to Catalog 8501CT1105



783 Clear Cover



783 Full-Feature Cover

**783 Series—3PDT 15 A**

Contact Rating	Contact Configuration	Nominal Voltage	Coil Resistance (Ω)	Standard Part Number		
				Clear Cover	Clear Cover with LED	Full-Feature
15 A	3PDT	12 Vac, 50/60 Hz	30	783XCXC12A	783XCXCL12A	783CXM4L12A
		24 Vac, 50/60 Hz	110	783XCXC24A	783XCXCL24A	783CXM4L24A
		48 Vac, 50/60 Hz	460	783XCXC48A	783XCXCL48A	783CXM4L48A
		120 Vac, 50/60 Hz	2880	783XCXC120A	783XCXCL120A	783CXM4L120A
		240 Vac, 50/60 Hz	11300	783XCXC240A	783XCXCL240A	783CXM4L240A
		12 Vdc	80	783XCXC12D	783XCXCL12D	783CXM4L12D
		24 Vdc	320	783XCXC24D	783XCXCL24D	783CXM4L24D
		48 Vdc	1280	783XCXC48D	783XCXCL48D	783CXM4L48D
		110 Vdc	6720	783XCXC110D	783XCXCL110D	783CXM4L110D

**Dimensions, in. (mm)**

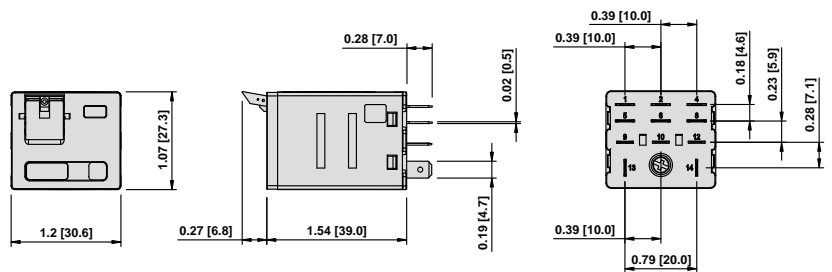
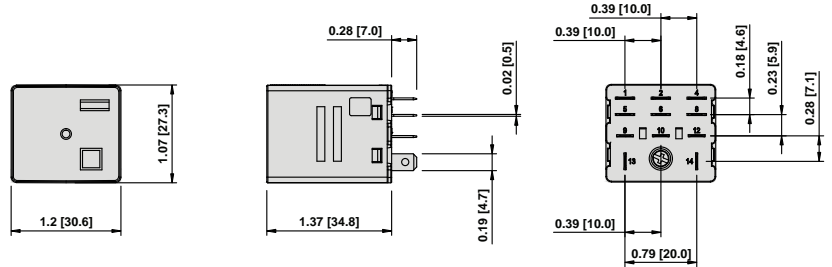

**Wiring Diagram**

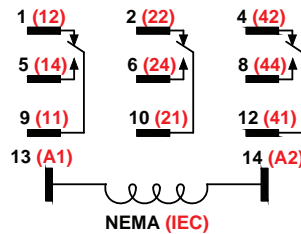

**Relay Accessories**

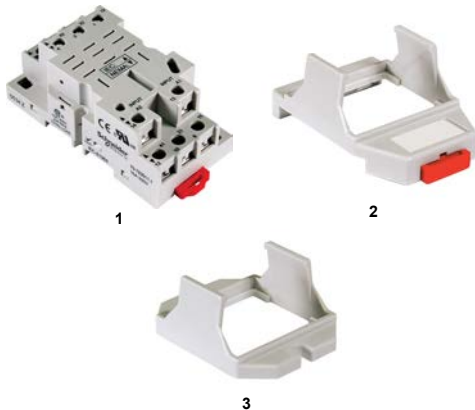

Description	Function	For Use with Relays	Pkg. Min.	Standard Part Number
1	Socket	DIN or panel mounting (finger-safe according to IP20), with screw terminals and clamping plates	10	70783D111A
2	Adapter	Direct DIN rail mounting	10	16783C
3	Adapter	Direct panel mounting	10	16783C1

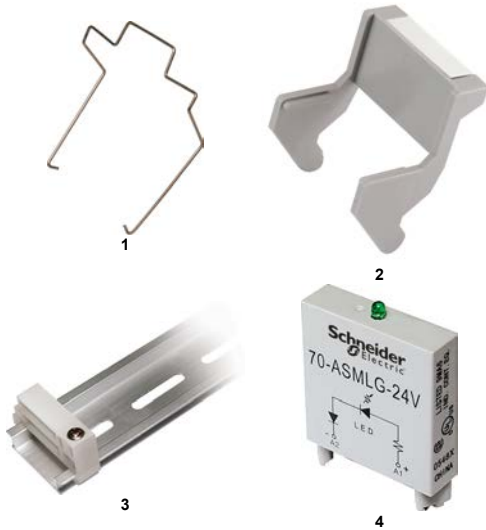

Socket Accessories

Description	Function	For Use with Sockets	Coil Voltage	Pkg. Min.	Standard Part Number
1 Metal Spring Clip	Securing the relay in the socket	70783D111A	—	10	16783SC
2 Plastic ID Hold-Down Clip	Securing the relay in the socket and providing labeling		—	10	16783IDC
3 Extruded Aluminum DIN Rail, 1 m (39.37 in.)	Quick installation and removal of sockets		—	10	16700DIN
3 DIN Rail End Clip	Holding the sockets firmly in place on a DIN rail	—	—	10	16DCLIP1
Large Socket Module					
MOV Suppressor	Protection from damaging electrical spikes	70783D111A	24 Vac/Vdc	10	70ASMM24
Protection Diode	Protecting the external drive circuitry from inductive voltages		250 Vdc	10	70ASMD250
4 LED Indicator	Providing coil status at a glance		110/240 Vac/Vdc	10	70ASMLG110/240
RC Suppressor	Snubbing back the EMF of the relay coil		110/240 Vac/Vdc	10	70ASMR110/240

NOTE: Using an LED or RC socket module can increase the coil power draw by up to 10%.

784 Series—4PDT 15 A



784 Clear Cover

784 Full-Feature Cover

Contact Rating	Contact Configuration	Nominal Voltage	Coil Resistance (Ω)	Standard Part Number		
				Clear Cover	Clear Cover with LED	Full-Feature
15 A	3PDT	12 Vac, 50/60 Hz	20	784DXC12A	784DXCL12A	784DXM4L12A
		24 Vac, 50/60 Hz	80	784DXC24A	784DXCL24A	784DXM4L24A
		48 Vac, 50/60 Hz	310	784DXC48A	784DXCL48A	784DXM4L48A
		120 Vac, 50/60 Hz	2100	784DXC120A	784DXCL120A	784DXM4L120A
		240 Vac, 50/60 Hz	8000	784DXC240A	784DXCL240A	784DXM4L240A
		12 Vdc	76	784DXC12D	784DXCL12D	784DXM4L12D
		24 Vdc	303	784DXC24D	784DXCL24D	784DXM4L24D
		48 Vdc	1210	784DXC48D	784DXCL48D	784DXM4L48D
		110 Vdc	6370	784DXC110D	784DXCL110D	784DXM4L110D

Dimensions, in. (mm)

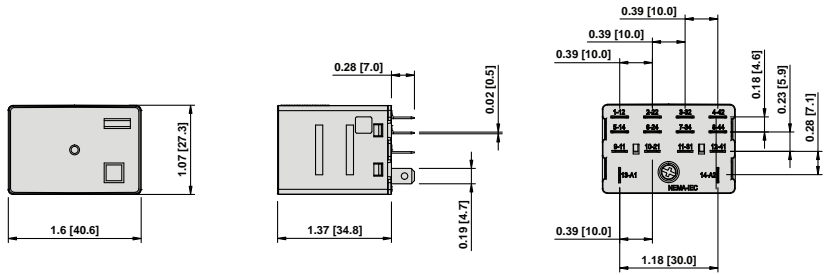

Clear Cover Dimensions

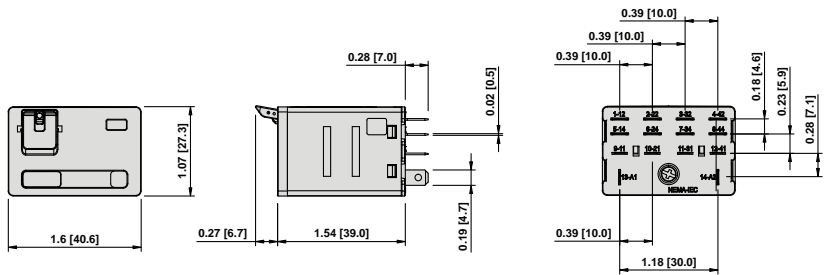

Full-Feature Cover Dimensions

**Wiring Diagram**

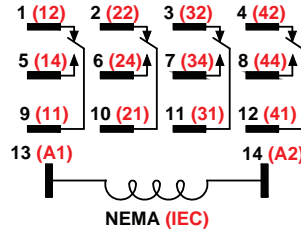

**Relay Accessories**

Description	Function	For Use with Relays	Pkg. Min.	Standard Part Number
1 Socket	DIN or panel mounting (finger-safe according to IP20), with screw terminals and clamping plates	784DXD	10	70784D141
2 Adapter	Direct DIN rail mounting		10	16784C
3 Adapter	Flange mount adapter		10	16783C1

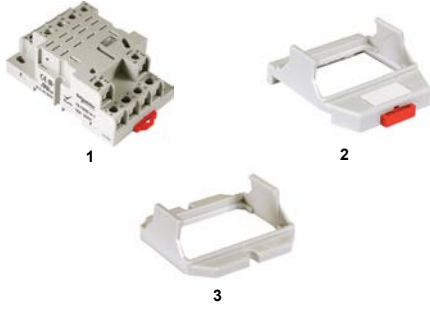

**Socket Accessories**

Description	Function	For Use with Sockets	Coil Voltage	Pkg. Min.	Standard Part Number
1 Metal Spring Clip	Securing the relay in the socket	70784D141	—	10	16784SC
2 Plastic ID Hold-Down Clip	Securing the relay in the socket and providing labeling		—	10	16784IDC
3 Extruded Aluminum DIN Rail, 1 m (39.37 in.)	Quick installation and removal of sockets		—	10	16700DIN
3 DIN Rail End Clip	Holding the sockets firmly in place on a DIN rail	—	—	10	16DCLIP1

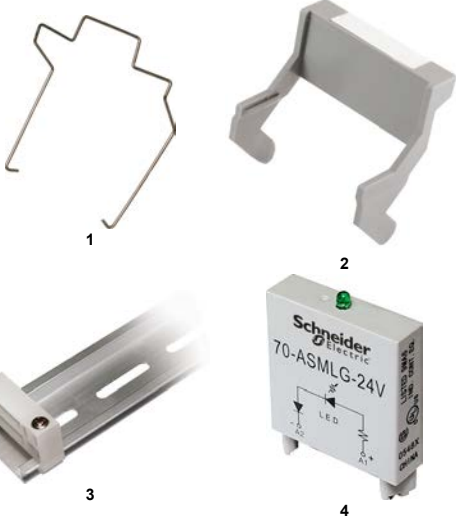

Large Socket Module					
MOV Suppressor	Protection from damaging electrical spikes	70784D141	24 Vac/Vdc	10	70ASMM24
Protection Diode	Protecting the external drive circuitry from inductive voltages		250 Vdc	10	70ASMD250
LED Indicator	Providing coil status at a glance		110/240 Vac/Vdc	10	70ASMLG110/240
RC Suppressor	Snubbing back the EMF of the relay coil		110/240 Vac	10	70ASMR110/240

**NOTE:** Using an LED or RC socket module can increase the coil power draw by up to 10%.



UL Listed when used with corresponding sockets



750R Clear Cover



750R Full-Feature Cover

**750R Series Universal Relays**  
DPDT and 3PDT, 10 A

**Description**

The 750R series octal base, plug-in relays offer clear or full-feature covers with multiple mounting options and accessories.

Feature	Benefit
Octal style mounting	Robust and historically proven mounting platform that provides excellent structural support
10 A max. switching current	Ideal choice for automation panels and controls
Clear or full-feature cover options	Full-feature covers include an LED indicator and a locking test button
DPDT and 3PDT contact configurations	Simultaneous control of separate circuits
Socket-mounting option	Simplified installation and maintenance; use of protection modules, hold-down clips, and other accessories
Gold-flashed contacts	Reduced contact oxidation and increased shelf life
Mechanical flag indicator (standard)	Display of the relay status during testing or operation

Contact Rating	Contact Configuration	Nominal Voltage	Coil Resistance (Ω)	Standard Part Number			
				Clear Cover	Clear Cover with LED	Full-Feature	
10 A	DPDT	6 Vac, 50/60 Hz	3.9	750XBXR6A	—	—	
		12 Vac, 50/60 Hz	16.9	750XBXR12A	750XBXRCL12A	750XBXR4L12A	
		24 Vac, 50/60 Hz	72	750XBXR24A	750XBXRCL24A	750XBXR4L24A	
		48 Vac, 50/60 Hz	290	—	—	750XBXR4L48A	
		120 Vac, 50/60 Hz	1700	750XBXR120A	750XBXRCL120A	750XBXR4L120A	
		240 Vac, 50/60 Hz	6800	750XBXR240A	750XBXRCL240A	750XBXR4L240A	
	3PDT	6 Vdc	6 Vdc	3.9	750XBXR6D	—	750XBXR4L6D
			12 Vdc	120	750XBXR12D	750XBXRCL12D	750XBXR4L12D
			24 Vdc	470	750XBXR24D	750XBXRCL24D	750XBXR4L24D
			48 Vdc	1800	750XBXR48D	750XBXRCL48D	750XBXR4L48D
			110 Vdc	7300	750XBXR110D	750XBXRCL110D	750XBXR4L110D
			240 Vac, 50/60 Hz	72	750XCXR24A	750XCXRCL24A	750XCXR4L24A
		120 Vac, 50/60 Hz	48 Vac, 50/60 Hz	290	—	—	750XCXR4L48A
			120 Vac, 50/60 Hz	1700	750XCXR120A	750XCXRCL120A	750XCXR4L120A
			240 Vac, 50/60 Hz	6800	750XCXR240A	750XCXRCL240A	750XCXR4L240A
			12 Vdc	120	750XCXR12D	750XCXRCL12D	750XCXR4L12D
			24 Vdc	470	750XCXR24D	750XCXRCL24D	750XCXR4L24D
			48 Vdc	1800	750XCXR48D	750XCXRCL48D	750XCXR4L48D
110 Vdc	7300	750XCXR110D	750XCXRCL110D	750XCXR4L110D			

**Specifications**

Part Number	750XBXR		750CXR
<b>Contact Characteristics</b>			
Terminal Style	Octal		Octal
Contact Material	Silver Alloy		Silver Alloy
Contact Configuration	DPDT		3PDT
Carrying Current	10 A		10 A
Maximum Switching Voltage	IEC: 250 Vac / 28 Vdc UL/CSA: 300 Vac / 30 Vdc		IEC: 250 Vac / 28 Vdc UL/CSA: 300 Vac / 30 Vdc
Rated Switching Current (Conforming to IEC AC-1 and DC-1)	N.O.: 10 A at 250 Vac / 28 Vdc N.C.: 5 A at 250 Vac / 28 Vdc		N.O.: 10 A at 250 Vac / 28 Vdc N.C.: 5 A at 250 Vac / 28 Vdc
Rated Switching Current (Conforming to UL)	Resistive	10 A at 277 Vac, 50/60 Hz, 200 k cycles	
		10 A at 30 Vdc, 200 k cycles	
		10 A at 277 Vac, 50/60 Hz, 200 k cycles	
Rated Switching Current (Conforming to UL)	Motor	1/3 hp at 120 Vac, 6 k cycles	
		1 hp at 277 Vac, 6 k cycles	
Rated Switching Current (Conforming to UL)	Pilot Duty	B300, 6 k cycles	
		B300, 6 k cycles	
Minimum Switching Requirement	10 mA at 17 Vdc		10 mA at 17 Vdc
<b>Coil Characteristics</b>			
Maximum Operating Voltage	110% (AC/DC)		
Maximum Pickup Voltage	85% (AC); 80% (DC)		
Drop-out Voltage Threshold	15% (AC); 10% (DC)		
Average Consumption	3 VA (AC); 1.4 W (DC)		

**Dimensions, in. (mm)**

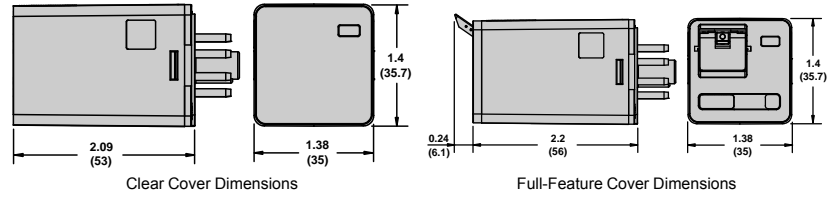

**Wiring Diagrams**

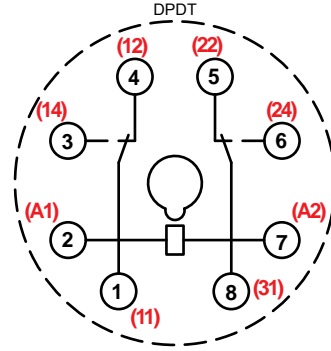

**NEMA (IEC)**

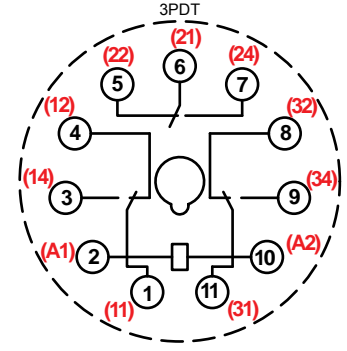

**NEMA (IEC)**

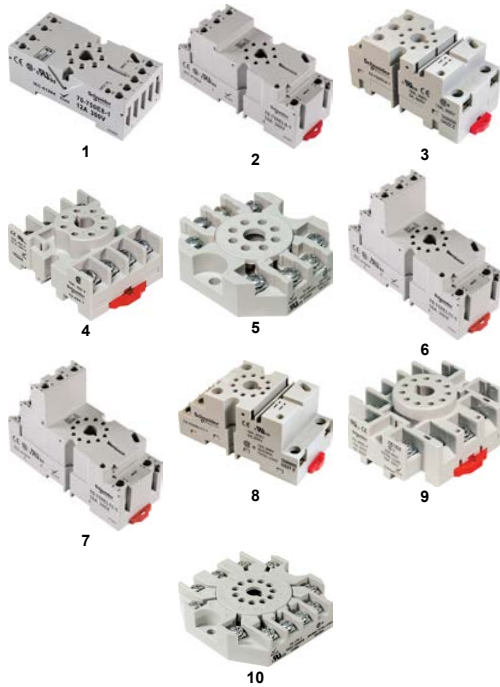

**Relay Accessories**

Description	Function	For Use with Relays	Pkg. Min.	Standard Part Number
1	Socket	DIN or panel mounting, module compatible	10	70750E81
2	Socket	DIN or panel mounting with elevator terminals, module compatible	10	70750EL81
3	Socket	DIN or panel mounting, module compatible	10	70750DL81
4	Socket	DIN or panel mounting with screw terminals and clamping plates	10	704641
5	Socket	Panel mounting with screw terminals and clamping plates	10	701691
6	Socket	DIN or panel mounting with elevator terminals, module compatible	10	70750E111
7	Socket	DIN or panel mounting with elevator terminals	10	70750EL111
8	Socket	DIN or panel mounting, module compatible	10	70750DL111
9	Socket	DIN or panel mounting with screw terminals and clamping plates	10	704651
10	Socket	Panel mounting with screw terminals and clamping plates	10	701701

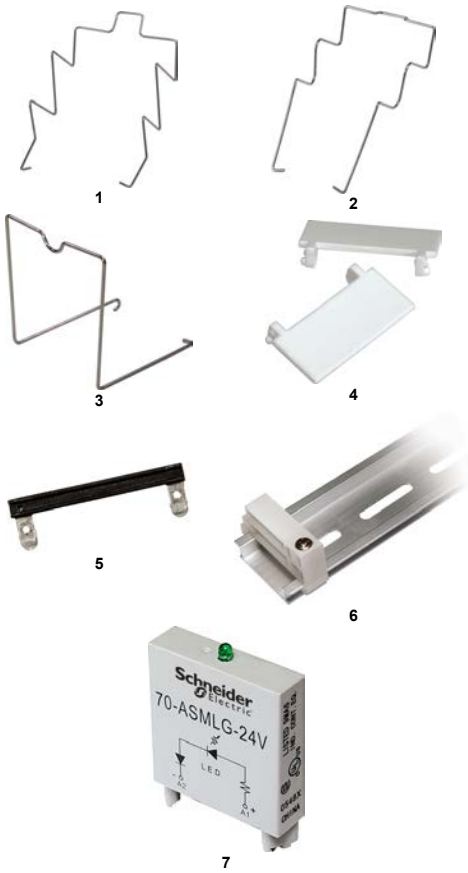

Socket Accessories

Description	Function	For Use with Sockets	Coil Voltage	Pkg. Min.	Standard Part Number	
1	Metal Spring Clip	Securing the relay in the socket	70750EL81, 70750E81, 70750E111, 704641	—	10	161351
2	Metal Spring Clip	Securing the relay in the socket	70750E81, 70750DL81, 70750E111, 704641	—	10	161344
3	Metal Spring Clip	Securing the relay in the socket	70750DL81	—	10	161332
4	Plastic ID Tag	Write-on plastic labels	70750E81, 70750EL81, 70750DL81, 70750E111, 70750EL11, 70750DL111	—	10	16750/788FT1
5	Insulated Coil Bus Jumper System	Wireless socket connection	70750E111, 70750EL11, 70750DL111	—	10	16750/788CBJ1
6	Extruded Aluminum DIN Rail, 1 m (39.37 in.)	Quick installation and removal of sockets	70750EL81, 70750E81, 70750DL81, 70750E111, 704641, 704651	—	10	16700DIN
6	DIN Rail End Clip	Plastic end clip with locking screw	—	—	10	16DCLIP1
<b>Large Socket Modules</b>						
	MOV Suppressor	Protection from damaging electrical spikes		24 Vac/Vdc	10	70ASMM24
	Protection Diode	Protecting the external drive circuitry from inductive voltages	70750E81, 70750EL81, 70750DL81, 70750E111, 70750EL111, 70750DL111	250 Vdc	10	70ASMD250
7	LED Indicator	Providing coil status at a glance		110/240 Vac/Vdc	10	70ASMLG110/240
	RC Suppressor	Snubbing back the EMF of the relay coil		110/240 Vac	10	70ASMR110/240

**NOTE:** Using an LED or RC socket module can increase the coil power draw by up to 10%.



7885 Clear Cover

7885 Full-Feature Cover

**788R Series Universal Relays**  
**DPDT and 3PDT 10 A**

**Description**

The 788R Series square base, plug-in relays offer clear, full-feature, top flange, and side flange covers as well as optional sockets and accessories.

Feature	Benefit
10 A max. switching current	Ideal choice for automation panels and controls
Clear or full-feature cover options	Full-feature covers include an LED indicator and a locking test button
DPDT and 3PDT contact configurations	Simultaneous control of separate circuits
Socket-mounting option	Simplified installation and maintenance; use of protection modules, hold-down clips, and other accessories
Gold-flashed contacts	Reduced contact oxidation and increased shelf life
Mechanical flag indicator (standard)	Display of the relay status during testing or operation

Contact Rating	Contact Configuration	Nominal Voltage	Coil Resistance (Ω)	Standard Part Number				
				Clear Cover	Clear Cover with LED	Flange Mount	Full-Feature	
10 A	DPDT	24 Vac, 50/60 Hz	72	788XBXRCL24A	788XBXRCL24A	788XBXRCL24A	788XBXRCL24A	
		48 Vac, 50/60 Hz	290	—	—	—	788XBXRCL48A	
		120 Vac, 50/60 Hz	1700	788XBXRCL120A	788XBXRCL120A	788XBXRCL120A	788XBXRCL120A	
		240 Vac, 50/60 Hz	6800	788XBXRCL240A	788XBXRCL240A	788XBXRCL240A	788XBXRCL240A	
		12 Vdc	120	788XBXRCL12D	788XBXRCL12D	788XBXRCL12D	788XBXRCL12D	
		24 Vdc	470	788XBXRCL24D	788XBXRCL24D	788XBXRCL24D	788XBXRCL24D	
	3PDT	48 Vdc	1800	788XBXRCL48D	788XBXRCL48D	788XBXRCL48D	788XBXRCL48D	
			7300	788XBXRCL110D	788XBXRCL110D	788XBXRCL110D	788XBXRCL110D	
		110 Vdc	12 Vac, 50/60 Hz	16.9	788XCXRCL12A	—	—	—
			24 Vac, 50/60 Hz	72	788XCXRCL24A	788XCXRCL24A	788XCXRCL24A	788XCXRCL24A
			48 Vac, 50/60 Hz	290	—	—	—	788XCXRCL48A
			120 Vac, 50/60 Hz	1700	788XCXRCL120A	788XCXRCL120A	788XCXRCL120A	788XCXRCL120A
			240 Vac, 50/60 Hz	6800	788XCXRCL240A	788XCXRCL240A	788XCXRCL240A	788XCXRCL240A
			12 Vdc	120	788XCXRCL12D	788XCXRCL12D	788XCXRCL12D	788XCXRCL12D
24 Vdc	470	788XCXRCL24D	788XCXRCL24D	788XCXRCL24D	788XCXRCL24D			
48 Vdc	1800	788XCXRCL48D	788XCXRCL48D	788XCXRCL48D	788XCXRCL48D			
110 Vdc	7300	788XCXRCL110D	788XCXRCL110D	788XCXRCL110D	788XCXRCL110D			

**NOTE:** Magnetic blowout versions are also available with an added contact rating of 3 A at 150 Vdc. Refer to the Part Number Explanation shown below.

**Specifications**

Part Number	788XBXR	788XCXR
<b>Contact Characteristics</b>		
Terminal Style	Blade	Blade
Contact Material	Silver Alloy	Silver Alloy
Contact Configuration	DPDT	3PDT
Carrying Current	10:00 AM	10:00 AM
Maximum Switching Voltage	IEC: 250 Vac / 28 Vdc UL/CSA: 300 Vac / 30 Vdc	IEC: 250 Vac / 28 Vdc UL/CSA: 300 Vac / 30 Vdc
Rated Switching Current (Conforming to IEC AC-1 and DC-1)	N.O.: 10 A at 250 Vac / 28 Vdc N.C.: 5 A at 250 Vac / 28 Vdc	N.O.: 10 A at 250 Vac / 28 Vdc N.C.: 5 A at 250 Vac / 28 Vdc
Rated Switching Current (Conforming to UL)	Resistive	10 A at 277 Vac, 50/60 Hz, 200 k cycles 10 A at 30 Vdc, 200 k cycles
	Motor	1/3 hp at 120 Vac, 6 k cycles 1 hp at 277 Vac, 6 k cycles
	Pilot Duty	B300, 6 k cycles
Rated Current with Magnetic Blowout (Code 69)	UL: 3 A at 150 Vdc (DPDT only), 6 k cycles	UL: 3 A at 150 Vdc (DPDT only), 6 k cycles
Minimum Switching Requirement	10 mA at 17 Vdc	10 mA at 17 Vdc
<b>Coil Characteristics</b>		
Maximum Operating Voltage	110% (AC/DC)	110% (AC/DC)
Maximum Pickup Voltage	85% (AC); 80% (DC)	85% (AC); 80% (DC)
Drop-out Voltage Threshold	15% (AC); 10% (DC)	15% (AC); 10% (DC)
Average Consumption	3 VA (AC); 1.4 W (DC)	3 VA (AC); 1.4 W (DC)

Dimensions, in. (mm)

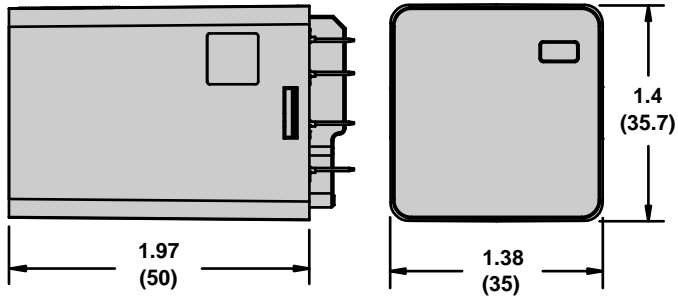

Clear Cover Dimensions

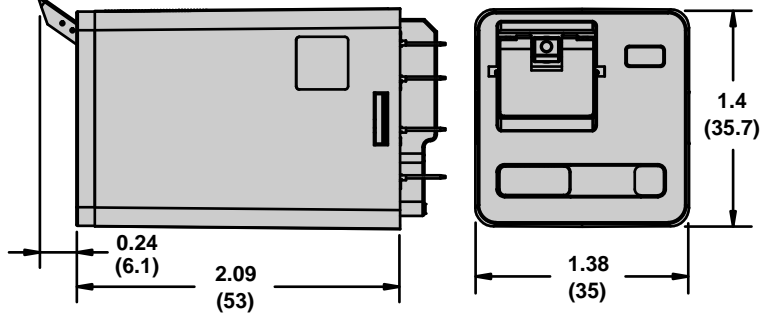

Full-Feature Cover Dimensions

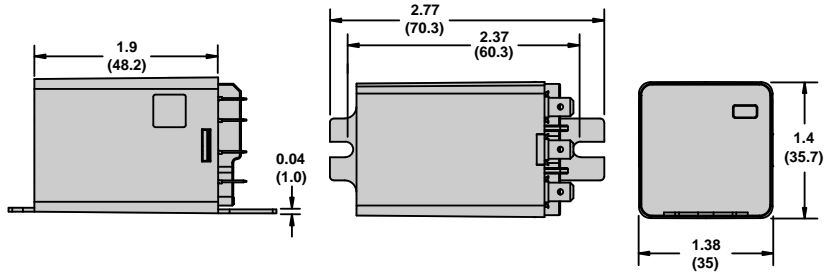

Side Flange Cover Dimensions

Wiring Diagrams

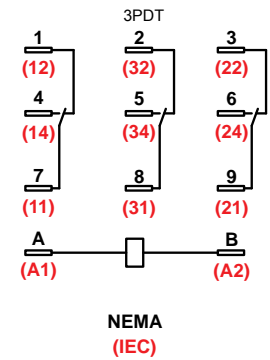
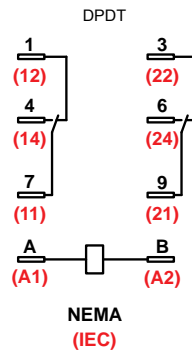
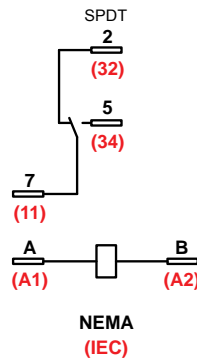

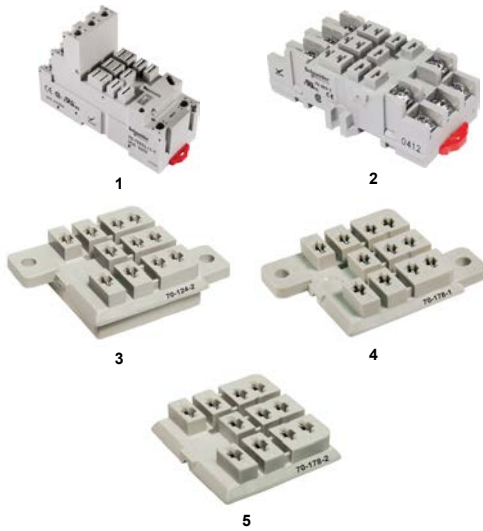

**Relay Accessories**

Description	Function	For Use with Relays	Pkg. Min.	Standard Part Number
1 Socket	DIN mounting with elevator terminals	788XBR/ XCXR	10	70788EL111
2 Socket	DIN or panel mounting with screw terminals and clamping plates		10	704631
3 Socket	0.187 in. Quick Connect terminals with mounting tabs		10	701242
4 Socket	Printed circuit terminals—with mounting tabs		10	701781
5 Socket	Printed circuit terminals—without mounting tabs		10	701782

**Socket Accessories**



Description	Function	For Use with Sockets	Coil Voltage	Pkg. Min.	Standard Part Number
1 Metal Spring Clip	Securing the relay in the socket	70788EL111, 704631, 701241, 701781, 701782	—	10	161351
2 Metal Spring Clip	Securing the relay in the socket	704631	—	10	161344
3 Insulated Coil Bus Jumper System	Wireless socket connection	70788EL111	—	10	16750/788CBJ1
4 Plastic ID Tag	Write-on plastic labels		—	10	16750/788FT1
5 Extruded Aluminum DIN Rail, 1 m (39.37 in.)	Quick installation and removal of sockets	70788EL111, 704631	—	10	16700DIN
5 DIN Rail End Clip	Holding the sockets firmly in place on a DIN rail	—	—	10	16DCLIP1
Large Socket Modules					
MOV Suppressor	Protection from damaging electrical spikes	70788EL111	24 Vac/Vdc	10	70ASMM24
Protection Diode	Protecting the external drive circuitry from inductive voltages		250 Vdc	10	70ASMD250
6 LED Indicator	Providing coil status at a glance		110/240 Vac/Vdc	10	70ASMLG110/240
RC Suppressor	Snubbing back the EMF of the relay coil		110/240 Vac	10	70ASMR110/240

**Socket Specifications**  
701242 Socket Specifications

<b>Part Number</b>		<b>701242</b>
Contact Configuration		3PDT
Number of Terminals		11
Mounting Style		Panel / Chassis
Current Rating		15 A
Nominal Voltage Rating		300 V
Temperature Range	Storage	-40 to +105°C (-40 to +221°F)
	Operating	-40 to +55°C (-40 to +131°F)
Protection Category		IP20
Internal Metal Tracks		Copper Alloy, Zinc Plated
Screw Terminals		Copper Alloy, Zinc Plated
Screw Style		—
Screw Size		—
Maximum Screw Torque		—
Terminal Connection		Solder
Terminal Layout		Mix
Maximum Wire Size	Solid Copper (Output)	16 AWG, 1.0 mm <sup>2</sup>
	Stranded Copper (Output)	16 AWG, 1.0 mm <sup>2</sup>
DIN Rail Mounting, EN 60715		—
Chassis Mount Screw Torque		—
Flammability Rating		94V-0
Weight		12.1 g (0.43 oz)
Agency Approvals		UL (E70550), CE, CSA (LR40787), RoHS

**Dimensions, in. (mm)**

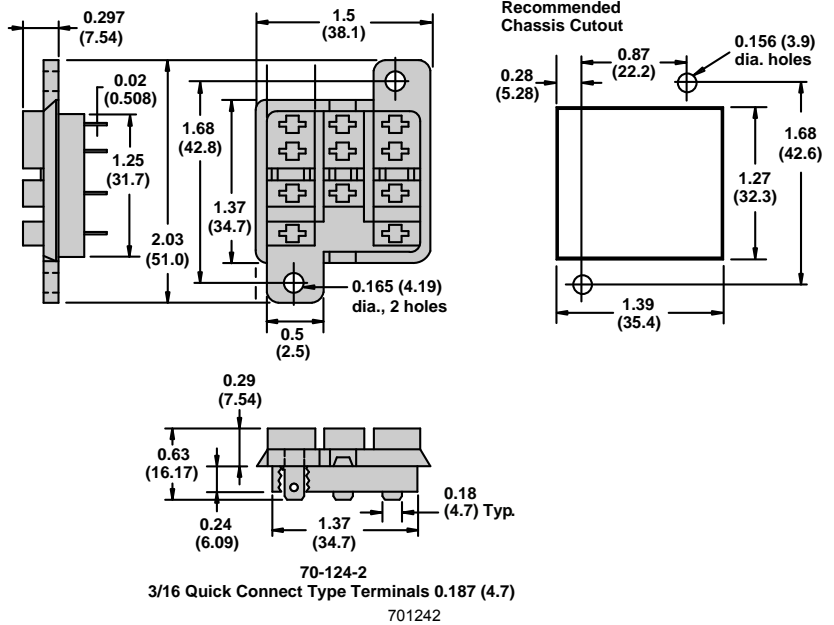

**Wiring Diagram**

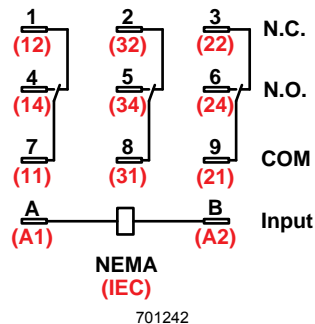

**701691 and 701701 Socket Specifications**

Part Number		701691	701701
Contact Configuration		DPDT	3PDT
Number of Terminals		8	11
Mounting Style		Panel	Panel
Current Rating		15 A	15 A
Nominal Voltage Rating		300 V	300 V
Temperature Range	Storage	-40 to +105°C (-40 to +221°F)	-40 to +105°C (-40 to +221°F)
	Operating	-40 to +55°C (-40 to +131°F)	-40 to +55°C (-40 to +131°F)
Protection Category		—	—
Internal Metal Tracks		Copper Alloy, Zinc Plated	Copper Alloy, Zinc Plated
Screw Terminals		Steel, Zinc Plated	Steel, Zinc Plated
Screw Style		Combination Head	Combination Head
Screw Size		M3.5 mm	M3.5 mm
Maximum Screw Torque		9 lb-in (1.0 N•m)	9 lb-in (1.0 N•m)
Terminal Connection		Screw Clamping	Screw Clamping
Terminal Layout		Mix	Mix
Maximum Wire Size	Solid Copper	Two 14–12 AWG (two 2.5–4 mm <sup>2</sup> )	Two 14–12 AWG (two 2.5–4 mm <sup>2</sup> )
	Stranded Copper	Two 14–12 AWG (two 2.5–4 mm <sup>2</sup> )	Two 14–12 AWG (two 2.5–4 mm <sup>2</sup> )
DIN Rail Mounting, EN 60715		35 mm	35 mm
Chassis Mount Screw Torque		7 lb-in (0.8 N•m)	7 lb-in (0.8 N•m)
Flammability Rating		94V-0	94V-0
Weight		57 g (2.01 oz)	57 g (2.01 oz)
Agency Approvals		UL (E70550), CE, CSA (LR97899), RoHS	UL (E70550), CE, CSA (LR97899), RoHS

**Dimensions, in, (mm)**

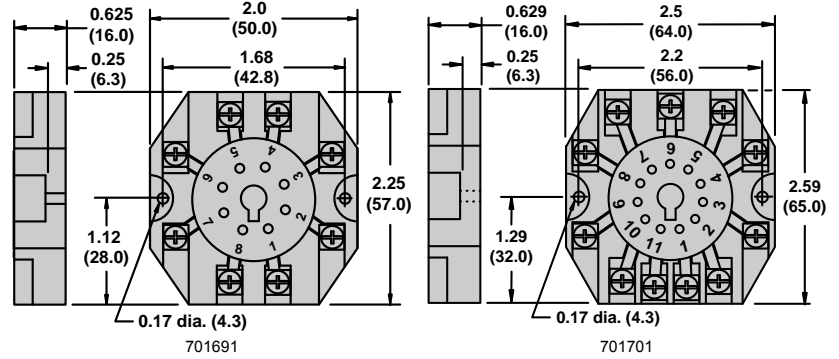

**Wiring Diagrams**

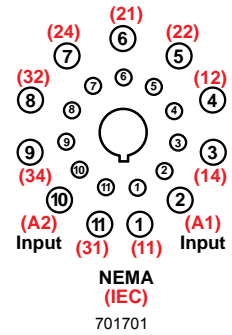
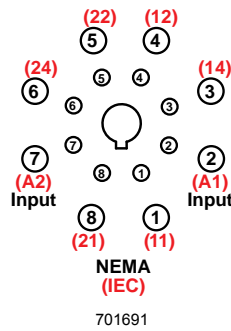

701781 and 701782 Socket Specifications

Part Number	701781	701782
Contact Configuration	3PDT	3PDT
Number of Terminals	11	11
Mounting Style	Panel / PCB	PCB
Current Rating	15 A	15 A
Nominal Voltage Rating	300 V	300 V
Temperature Range	Storage	-40 to +105°C (-40 to +221°F)
	Operating	-40 to +55°C (-40 to +131°F)
Protection Category	IP20	IP20
Internal Metal Tracks	Copper Alloy, Zinc Plated	Copper Alloy, Zinc Plated
Screw Terminals	Copper Alloy, Zinc Plated	Copper Alloy, Zinc Plated
Screw Style	—	—
Screw Size	—	—
Maximum Screw Torque	—	—
Terminal Connection	PCB	PCB
Terminal Layout	Mix	Mix
Maximum Wire Size	Solid Copper (Output)	16 AWG, 1.0 mm <sup>2</sup>
	Stranded Copper (Output)	16 AWG, 1.0 mm <sup>2</sup>
DIN Rail Mounting, EN 60715	—	—
Chassis Mount Screw Torque	—	—
Flammability Rating	94V-0	94V-0
Weight	12.1 g (0.43 oz)	12.1 g (0.43 oz)
Agency Approvals	UL (E70550), CE, CSA (LR40787), RoHS	UL (E70550), CE, CSA (LR40787), RoHS

Dimensions, in. (mm)

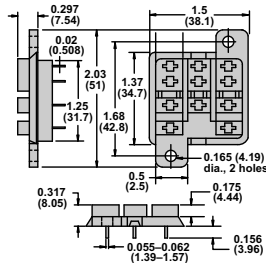

70178

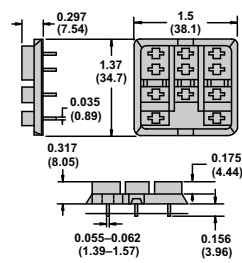

701782

Recommended Circuit Board Layout For 70-178-1 & 70-178-2 Bottom View

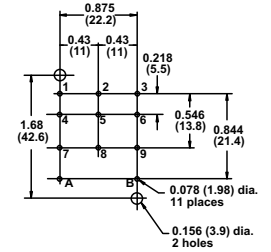

Wiring Diagram

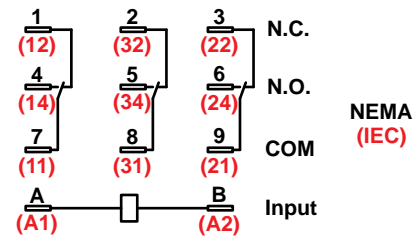

**703781 and 703791 Socket Specifications**

Part Number	703781	703791
Contact Configuration	4PDT	4PDT
Number of Terminals	14	14
Mounting Style	Chassis	PCB
Current Rating	5 A	5 A
Nominal Voltage Rating	120 V	120 V
Temperature Range	Storage	-40 to +105°C (-40 to +221°F)
	Operating	-40 to +55°C (-40 to +131°F)
Protection Category	—	—
Internal Metal Tracks	Copper Alloy, Zinc Plated	Copper Alloy, Zinc Plated
Screw Terminals	Copper Alloy, Zinc Plated	Copper Alloy, Zinc Plated
Screw Style	—	—
Screw Size	—	—
Maximum Screw Torque	—	—
Terminal Connection	Solder	PCB
Terminal Layout	Mix	Mix
Maximum Wire Size	Solid Copper (Output)	18 AWG, 0.8 mm <sup>2</sup>
	Stranded Copper (Output)	18 AWG, 0.8 mm <sup>2</sup>
DIN Rail Mounting, EN 60715	35 mm	—
Chassis Mount Screw Torque	7 lb-in (0.8 N·m)	—
Flammability Rating	94V-0	94V-0
Weight	6.2 g (0.22 oz)	5.8 g (0.20 oz)
Agency Approvals	UL (E70550), CE, CSA (LR40787), RoHS	UL (E70550), CE, CSA (LR40787), RoHS

**Dimensions, in, (mm)**

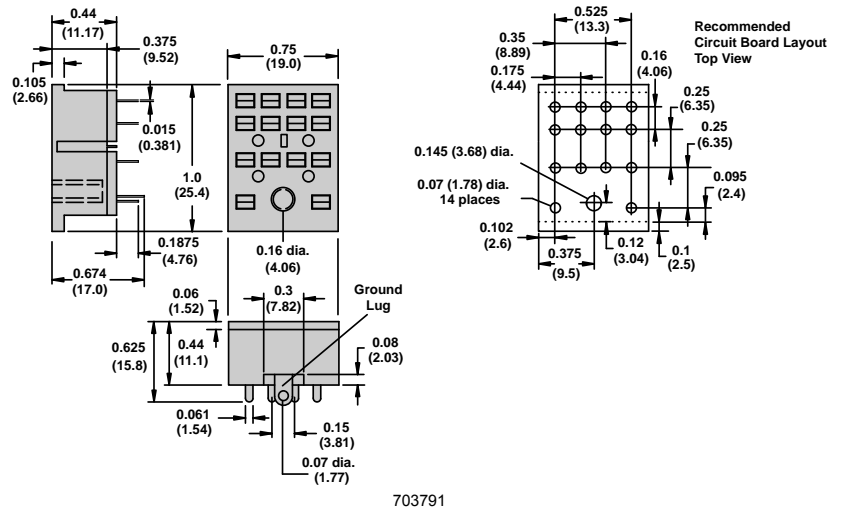
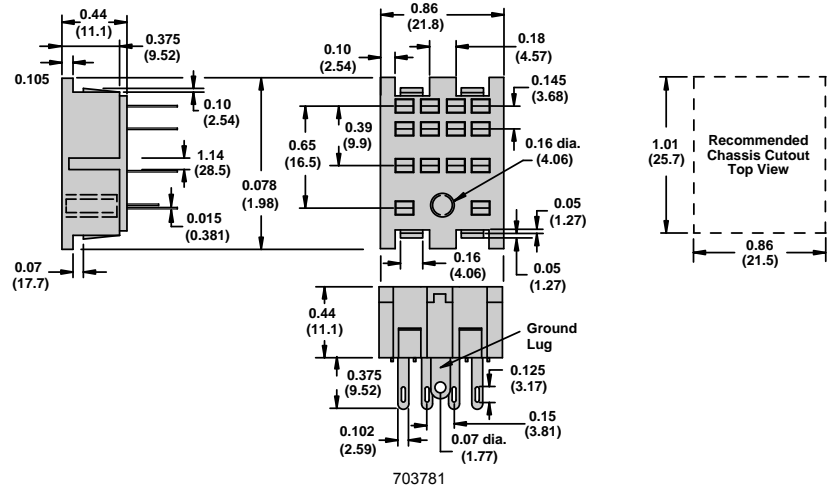

Wiring Diagrams

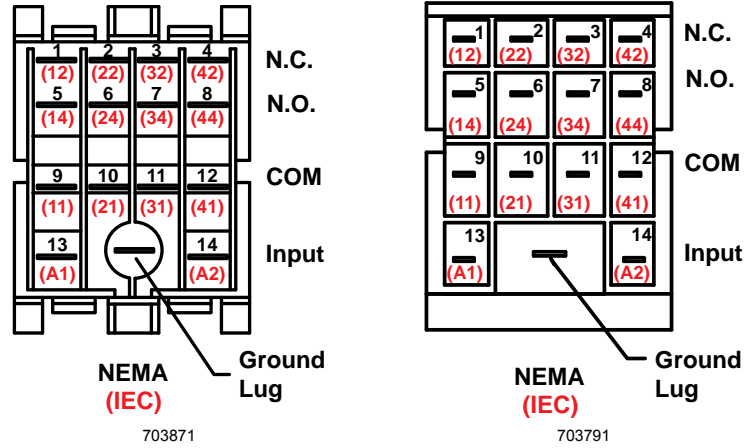

704011 and 704021 Socket Specifications

Part Number	704011	704021
Contact Configuration	DPDT	DPDT
Number of Terminals	8	8
Mounting Style	Chassis	PCB
Current Rating	10 A	10 A
Nominal Voltage Rating	300 V	300 V
Temperature Range	Storage	-40 to +105°C (-40 to +221°F)
	Operating	-40 to +55°C (-40 to +131°F)
Protection Category	—	—
Internal Metal Tracks	Copper Alloy, Zinc Plated	Copper Alloy, Zinc Plated
Screw Terminals	Copper Alloy, Zinc Plated	Copper Alloy, Zinc Plated
Screw Style	Combination Head	—
Screw Size	M3.5 mm	—
Maximum Screw Torque	9 lb-in (1.0 N•m)	—
Terminal Connection	Solder	PCB
Terminal Layout	Mix	Mix
Maximum Wire Size	Solid Copper (Output)	18 AWG, 0.8 mm <sup>2</sup>
	Stranded Copper (Output)	18 AWG, 0.8 mm <sup>2</sup>
DIN Rail Mounting, EN 60715	—	—
Chassis Mount Screw Torque	7 lb-in (0.8 N•m)	—
Flammability Rating	94V-0	94V-0
Weight	6.2 g (0.22 oz)	6.5 g (0.23 oz)
Agency Approvals	UL (E70550), CE, RoHS	UL (E70550), CE, RoHS

Dimensions, in, (mm)

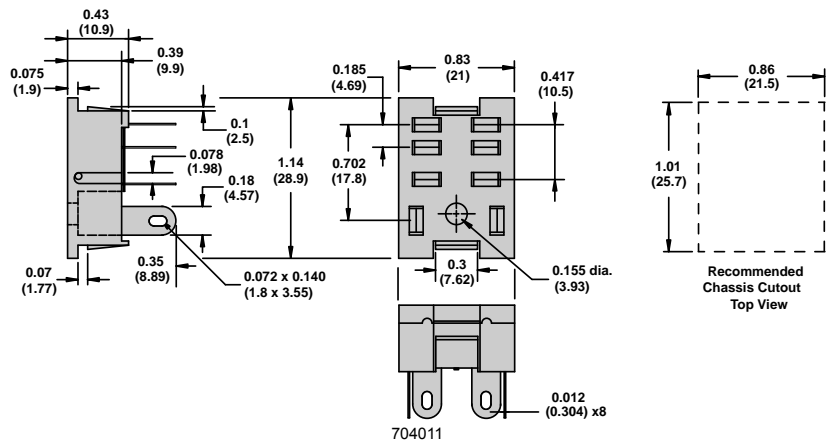

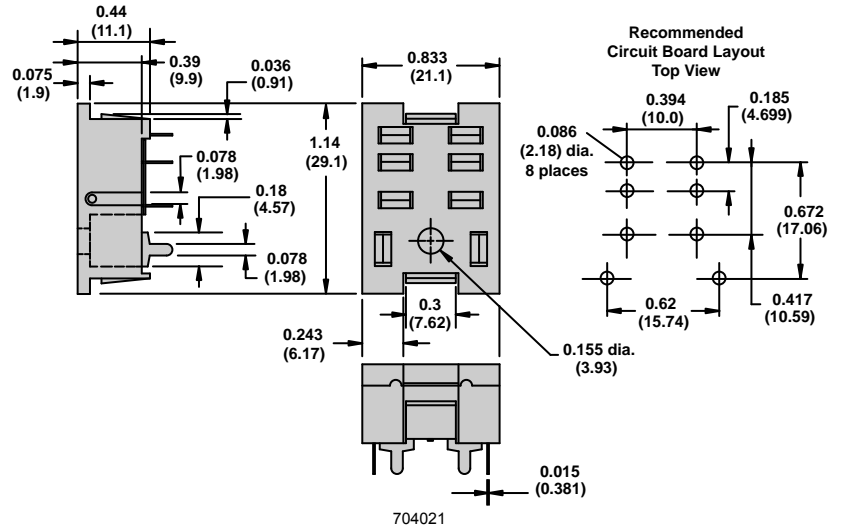

**Wiring Diagrams**

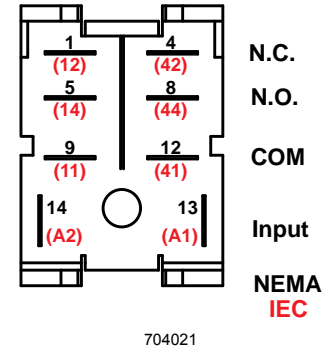
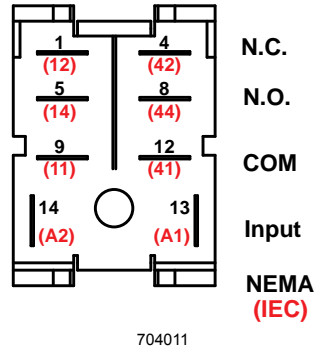

704591, 704611, and 704631 Socket Specifications

Part Number	704591	704611	704631
Contact Configuration	DPDT	4PDT	3PDT
Number of Terminals	8	14	11
Mounting Style	Panel or DIN rail	Panel or DIN rail	Panel or DIN rail
Current Rating	10 A	10 A	15 A
Nominal Voltage Rating	300 V	300 V	300 V
Temperature Range	Storage	-40 to +105°C (-40 to +221°F)	-40 to +105°C (-40 to +221°F)
	Operating	-40 to +55°C (-40 to +131°F)	-40 to +70°C (-40 to +158°F)
Protection Category	—	—	—
Internal Metal Tracks	Copper Alloy, Zinc Plated	Copper Alloy, Zinc Plated	Copper Alloy, Zinc Plated
Screw Terminals	Steel, Zinc Plated	Steel, Zinc Plated	Steel, Zinc Plated
Screw Style	Combination Head	Combination Head	Combination Head
Screw Size	M3.5 mm	M3 mm	M3.5 mm
Maximum Screw Torque	9 lb-in (1.0 N·m)	7 lb-in (0.8 N·m)	9 lb-in (1.0 N·m)
Terminal Connection	Screw Clamping	Screw Clamping	Screw Clamping
Terminal Layout	Mix	Mix	Mix
Maximum Wire Size	Solid Copper	Two 14–12 AWG (two 2.5–4 mm <sup>2</sup> )	Two 16–14 AWG (two 1.5–2.5 mm <sup>2</sup> )
	Stranded Copper	Two 14–12 AWG (two 2.5–4 mm <sup>2</sup> )	Two 16–14 AWG (two 1.5–2.5 mm <sup>2</sup> )
DIN Rail Mounting, EN 60715	35 mm	35 mm	35 mm
Chassis Mount Screw Torque	7 lb-in (0.8 N·m)	7 lb-in (0.8 N·m)	7 lb-in (0.8 N·m)
Flammability Rating	94V-0	94V-0	94V-0
Weight	50 g (1.76 oz)	50 g (1.76 oz)	51 g (1.79 oz)
Agency Approvals	UL (E70550), CE, CSA (LR97899), RoHS	UL (E70550), CE, CSA (LR97899), RoHS	UL (E70550), CE, CSA (LR97899), RoHS

Dimensions, in, (mm)

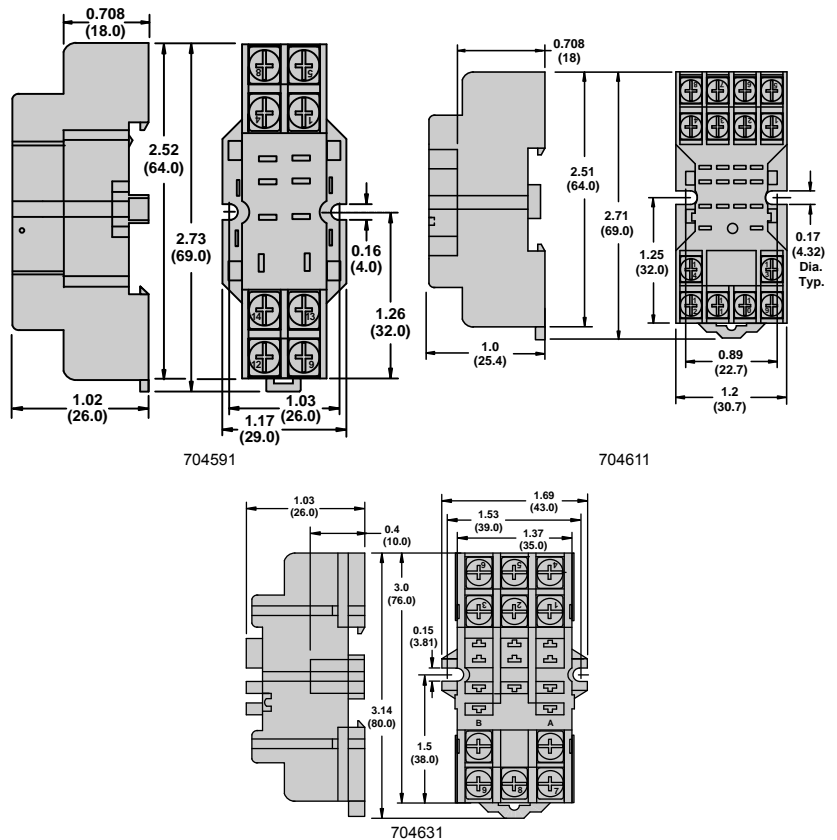

**Wiring Diagrams**

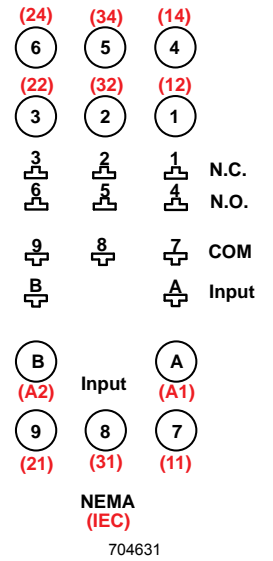
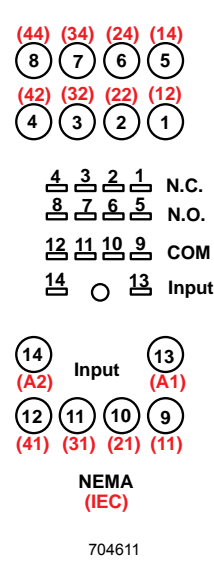
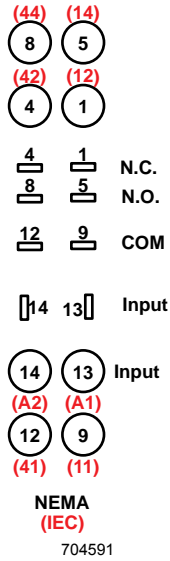

704641 and 704651 Socket Specifications

Contact Configuration		DPDT	SPDT
Number of Terminals		8	11
Mounting Style		Panel or DIN rail	Panel or DIN rail
Current Rating		15 / 10 A	15 / 5 A
Nominal Voltage Rating		300 / 600 V	300 / 600 V
Temperature Range	Storage	-40 to +105°C (-40 to +221°F)	-40 to +105°C (-40 to +221°F)
	Operating	-40 to +55°C (-40 to +131°F)	-40 to +55°C (-40 to +131°F)
Protection Category		—	—
Internal Metal Tracks		Copper Alloy, Zinc Plated	Copper Alloy, Zinc Plated
Screw Terminals		Steel, Zinc Plated	Steel, Zinc Plated
Screw Style		Combination Head	Combination Head
Screw Size		M3.5 mm	M3.5 mm
Maximum Screw Torque		9 lb-in (1.0 N•m)	9 lb-in (1.0 N•m)
Terminal Connection		Screw Clamping	Screw Clamping
Terminal Layout		Mix	Mix
Maximum Wire Size	Solid Copper	Two 14–12 AWG (two 2.5–4 mm <sup>2</sup> )	Two 14–12 AWG (two 2.5–4 mm <sup>2</sup> )
	Stranded Copper	Two 14–12 AWG (two 2.5–4 mm <sup>2</sup> )	Two 14–12 AWG (two 2.5–4 mm <sup>2</sup> )
DIN Rail Mounting, EN 60715		35 mm	35 mm
Chassis Mount Screw Torque		7 lb-in (0.8 N•m)	7 lb-in (0.8 N•m)
Flammability Rating		94V-0	94V-0
Weight		40 g (1.41 oz)	57 g (2.01 oz)
Agency Approvals		UL (E70550), CE, CSA (LR97899), RoHS	UL (E70550), CE, CSA (LR97899), RoHS

Dimensions, in. (mm)

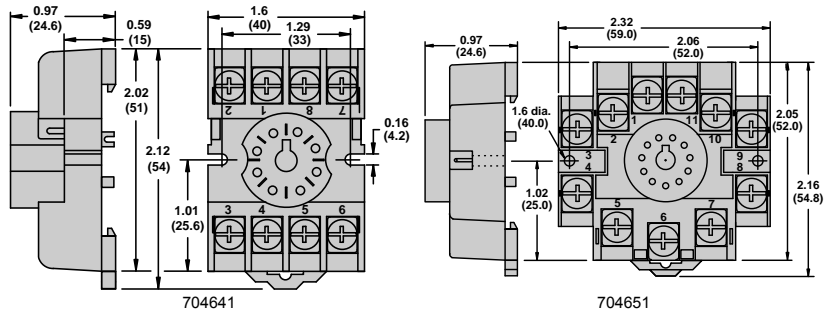

Wiring Diagrams

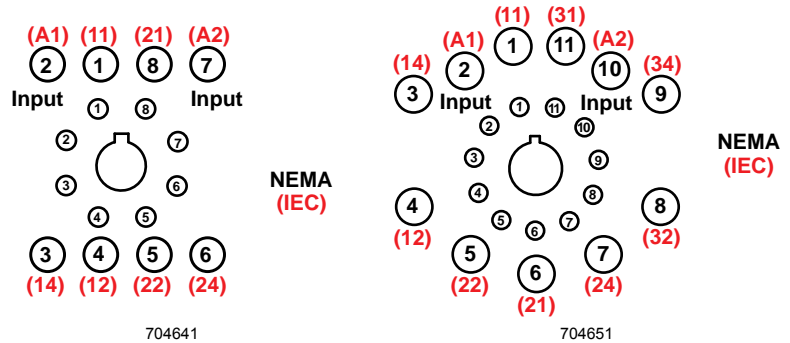

**70750DL81 and 70750DL111 Socket Specifications**

Part Number		70750DL81	70750DL111
Contact Configuration		DPDT	3PDT
Number of Terminals		8	11
Mounting Style		Panel or DIN rail	Panel or DIN rail
Current Rating		16 A	16 A
Nominal Voltage Rating		300 V	600 V
Temperature Range	Storage	-40 to +105°C (-40 to +221°F)	-40 to +105°C (-40 to +221°F)
	Operating	-40 to +55°C (-40 to +131°F)	-40 to +55°C (-40 to +131°F)
Protection Category		IP20	IP20
Internal Metal Tracks		Copper Alloy, Zinc Plated	Copper Alloy, Zinc Plated
Screw Terminals		Steel, Zinc Plated	Steel, Zinc Plated
Screw Style		Combination Head	Combination Head
Screw Size		M3.5 mm	M3.5 mm
Maximum Screw Torque		9 lb-in (1.0 N•m)	9 lb-in (1.0 N•m)
Terminal Connection		Screw Clamping	Screw Clamping
Terminal Layout		Mix	Mix
Maximum Wire Size	Solid Copper	Two 14–12 AWG (two 2.5–4 mm <sup>2</sup> )	Two 14–12 AWG (two 2.5–4 mm <sup>2</sup> )
	Stranded Copper	Two 14–12 AWG (two 2.5–4 mm <sup>2</sup> )	Two 14–12 AWG (two 2.5–4 mm <sup>2</sup> )
DIN Rail Mounting, EN 60715		35 mm	35 mm
Chassis Mount Screw Torque		7 lb-in (0.8 N•m)	7 lb-in (0.8 N•m)
Flammability Rating		94V-0	94V-0
Weight		60 g (2.12 oz)	78 g (2.75 oz)
Agency Approvals		UL (E70550), CE, CSA (LR40787), RoHS	UL (E70550), CE, CSA (LR40787), RoHS

**Dimensions, in, (mm)**

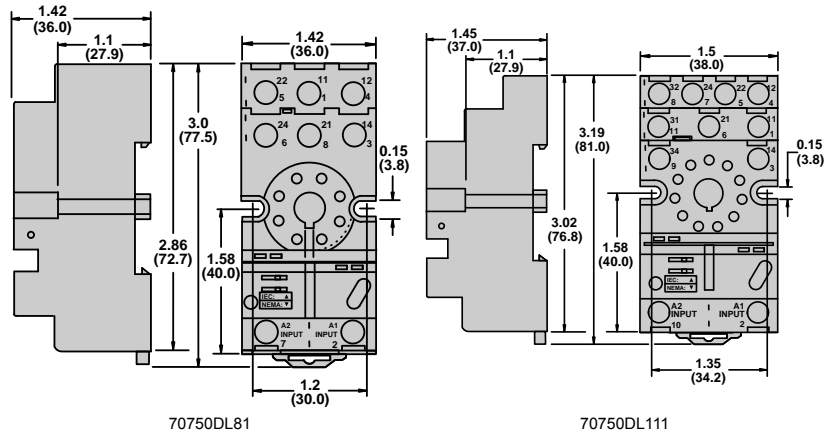

**Wiring Diagrams**

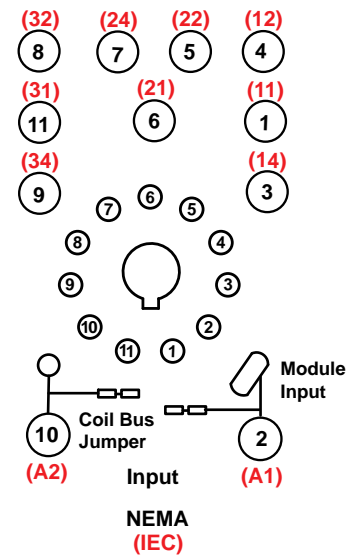
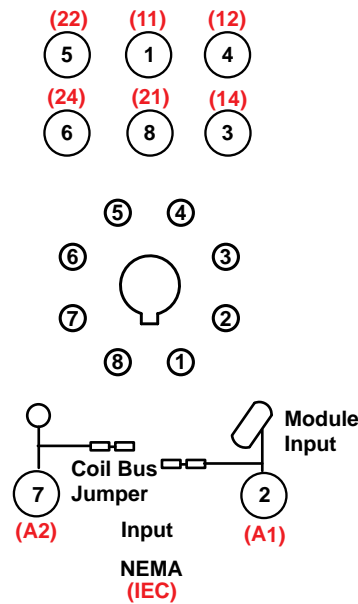

70750E81 and 70750E111 Socket Specifications

Part Number		70750E81	70750E111
Contact Configuration		DPDT	3PDT
Number of Terminals		8	11
Mounting Style		Panel or DIN rail	Panel or DIN rail
Current Rating		12 A	12 A
Nominal Voltage Rating		300 V	300 V
Temperature Range	Storage	-40 to +105°C (-40 to +221°F)	-40 to +105°C (-40 to +221°F)
	Operating	-40 to +55°C (-40 to +131°F)	-40 to +55°C (-40 to +131°F)
Protection Category		IP20	IP20
Internal Metal Tracks		Copper Alloy, Zinc Plated	Copper Alloy, Zinc Plated
Screw Terminals		Steel, Zinc Plated	Steel, Zinc Plated
Screw Style		Combination Head	Combination Head
Screw Size		M3.5 mm	M3.5 mm
Maximum Screw Torque		9 lb-in (1.0 N•m)	9 lb-in (1.0 N•m)
Terminal Connection		Elevator	Elevator
Terminal Layout		Separate	Separate
Maximum Wire Size	Solid Copper	Two 14–12 AWG (two 2.5–4 mm <sup>2</sup> )	Two 14–12 AWG (two 2.5–4 mm <sup>2</sup> )
	Stranded Copper	Two 14–12 AWG (two 2.5–4 mm <sup>2</sup> )	Two 14–12 AWG (two 2.5–4 mm <sup>2</sup> )
DIN Rail Mounting, EN 60715		35 mm	35 mm
Chassis Mount Screw Torque		7 lb-in (0.8 N•m)	7 lb-in (0.8 N•m)
Flammability Rating		94V-0	94V-0
Weight		85 g (3.0 oz)	85 g (3.0 oz)
Agency Approvals		UL (E70550), CE, CSA (LR40787), RoHS	UL (E70550), CE, CSA (LR40787), RoHS

Dimensions, in. (mm)

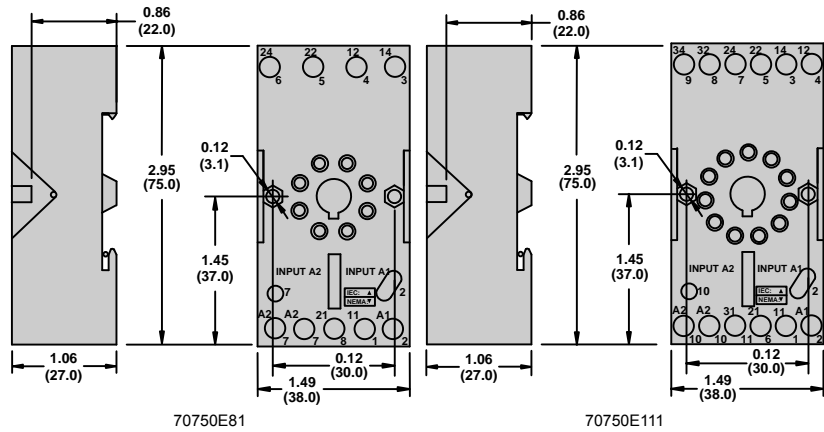

Wiring Diagrams

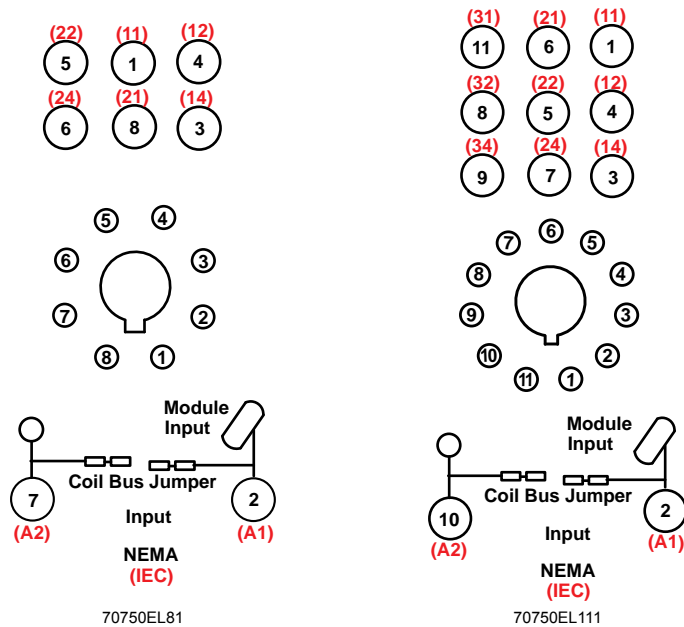

**70750EL81 and 70750EL111 Socket Specifications**

Part Number	70750EL81	70750EL111
Contact Configuration	DPDT	3PDT
Number of Terminals	8	11
Mounting Style	Panel or DIN rail	Panel or DIN rail
Current Rating	16 A	16 A
Nominal Voltage Rating	300 V	300 V
Temperature Range	Storage	-40 to +105°C (-40 to +221°F)
	Operating	-40 to +55°C (-40 to +131°F)
Protection Category	Storage	-40 to +105°C (-40 to +221°F)
	Operating	-40 to +55°C (-40 to +131°F)
Protection Category	IP20	IP20
Internal Metal Tracks	Copper Alloy, Zinc Plated	Copper Alloy, Zinc Plated
Screw Terminals	Steel, Zinc Plated	Steel, Zinc Plated
Screw Style	Combination Head	Combination Head
Screw Size	M3.5 mm	M3.5 mm
Maximum Screw Torque	9 lb-in (1.0 N·m)	9 lb-in (1.0 N·m)
Terminal Connection	Elevator	Elevator
Terminal Layout	Separate	Separate
Maximum Wire Size	Solid Copper	Two 14–12 AWG (two 2.5–4 mm <sup>2</sup> )
	Stranded Copper	Two 14–12 AWG (two 2.5–4 mm <sup>2</sup> )
DIN Rail Mounting, EN 60715	35 mm	35 mm
Chassis Mount Screw Torque	7 lb-in (0.8 N·m)	7 lb-in (0.8 N·m)
Flammability Rating	94V-0	94V-0
Weight	79 g (2.79 oz)	79 g (2.79 oz)
Agency Approvals	UL (E70550), CE, CSA (LR40787), RoHS	UL (E70550), CE, CSA (LR40787), RoHS

**Dimensions, in., (mm)**

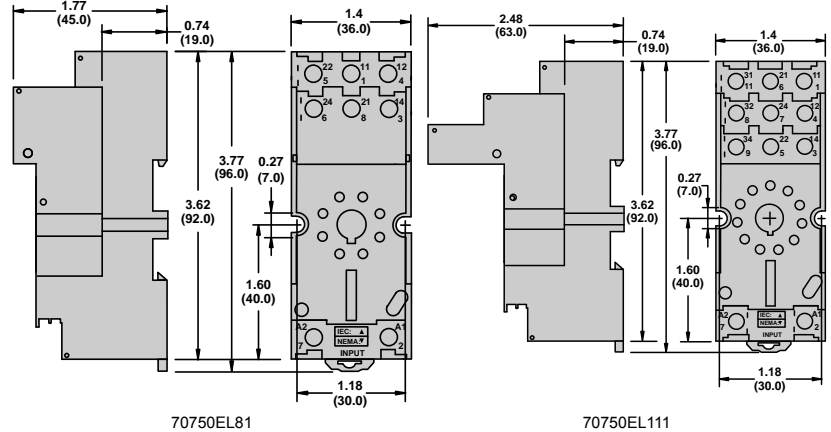

**Wiring Diagrams**

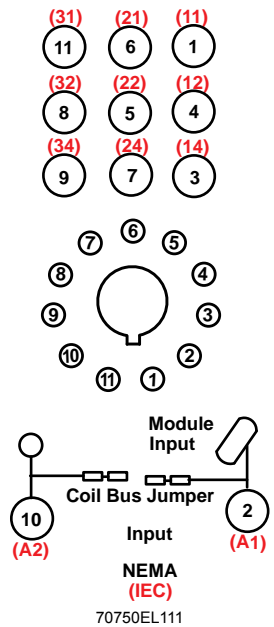
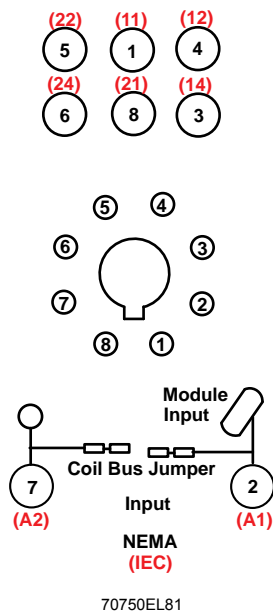

70781D5R1A and 70781T1 Socket Specifications

Part Number		70781D5R1A	70781T1
Contact Configuration		SPDT	SPDT
Number of Terminals		5	5
Mounting Style		Panel or DIN rail	PCB
Current Rating		16 A	10 A
Nominal Voltage Rating		300 V	300 V
Temperature Range	Storage	-40 to +85°C (-40 to +185°F)	-40 to +105°C (-40 to +221°F)
	Operating	-40 to +55°C (-40 to +131°F)	-40 to +55°C (-40 to +131°F)
Protection Category		IP20	—
Internal Metal Tracks		Copper Alloy, Zinc Plated	Copper Alloy, Zinc Plated
Screw Terminals		Steel, Zinc Plated	Copper Alloy, Zinc Plated
Screw Style		Combination Head	—
Screw Size		M3 mm / M3.5 mm	—
Maximum Screw Torque	M3	7 lb-in (0.8 N•m)	—
	M3.5	9 lb-in (1.0 N•m)	—
Terminal Connection		Screw Clamping	PCB
Terminal Layout		Mix	Mix
Maximum Wire Size	Solid Copper	Two 12 AWG (two 4 mm <sup>2</sup> ) without cable end	—
	Stranded Copper	Two 14 AWG (two 2.5 mm <sup>2</sup> ) with cable end	—
DIN Rail Mounting, EN 60715		35 mm	—
Chassis Mount Screw Torque		7 lb-in (0.8 N•m)	—
Flammability Rating		94V-0	94V-0
Weight		31 g (1.09 oz)	18 g (0.63 oz)
Agency Approvals		UL (E70550), CE, CSA (168986), RoHS	UL (E70550), CE, RoHS

Dimensions, in. (mm)

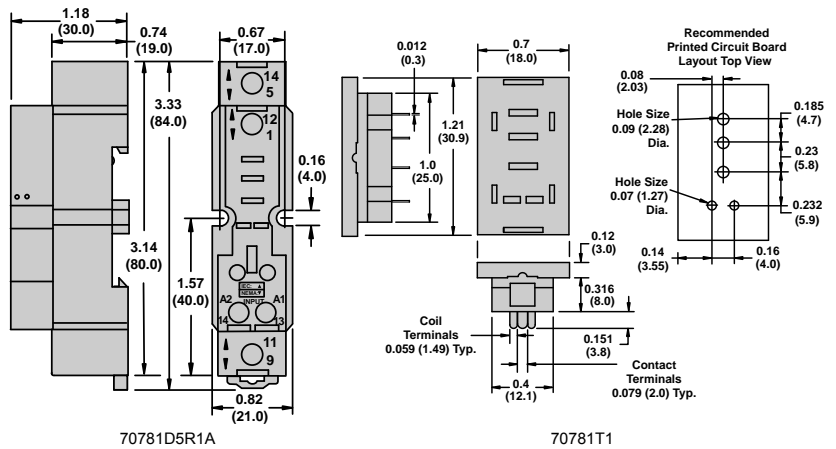

Wiring Diagrams

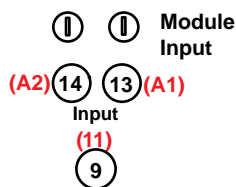
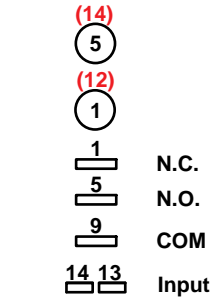

NEMA (IEC)  
70781D5R1A

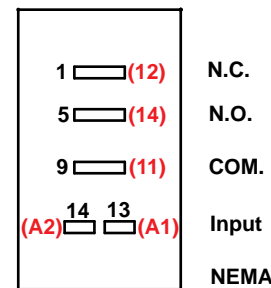

70781T1

**70782D81A and 70782D141 Socket Specifications**

Part Number	70782D81A	70782D141	
Contact Configuration	DPDT	4PDT	
Number of Terminals	8	14	
Mounting Style	Panel or DIN rail	Panel or DIN rail	
Current Rating	16 A	10 A	
Nominal Voltage Rating	300 V	300 V	
Temperature Range	Storage	-40 to +105°C (-40 to +221°F)	-40 to +105°C (-40 to +221°F)
	Operating	-40 to +55°C (-40 to +131°F)	-40 to +70°C (-40 to +158°F)
Protection Category	IP20	IP20	
Internal Metal Tracks	Copper Alloy, Zinc Plated	Copper Alloy, Zinc Plated	
Screw Terminals	Steel, Zinc Plated	Steel, Zinc Plated	
Screw Style	Combination Head	Combination Head	
Screw Size	M3.5 mm	M3 mm	
Maximum Screw Torque	9 lb-in (1.0 N•m)	7 lb-in (0.8 N•m)	
Terminal Connection	Screw Clamping	Screw Clamping	
Terminal Layout	Mix	Mix	
Maximum Wire Size	Solid Copper	Two 14–12 AWG (two 2.5–4 mm <sup>2</sup> )	Two 14–12 AWG (two 2.5–4 mm <sup>2</sup> )
	Stranded Copper	Two 14–12 AWG (two 2.5–4 mm <sup>2</sup> )	Two 14–12 AWG (two 2.5–4 mm <sup>2</sup> )
DIN Rail Mounting, EN 60715	35 mm	35 mm	
Chassis Mount Screw Torque	7 lb-in (0.8 N•m)	7 lb-in (0.8 N•m)	
Flammability Rating	94V-0	94V-0	
Weight	55 g (1.94 oz)	62 g (2.19 oz)	
Agency Approvals	UL (E70550), CE, CSA (LR40787), RoHS	UL (E70550), CE, CSA (LR40787), RoHS	

**Dimensions, in, (mm)**

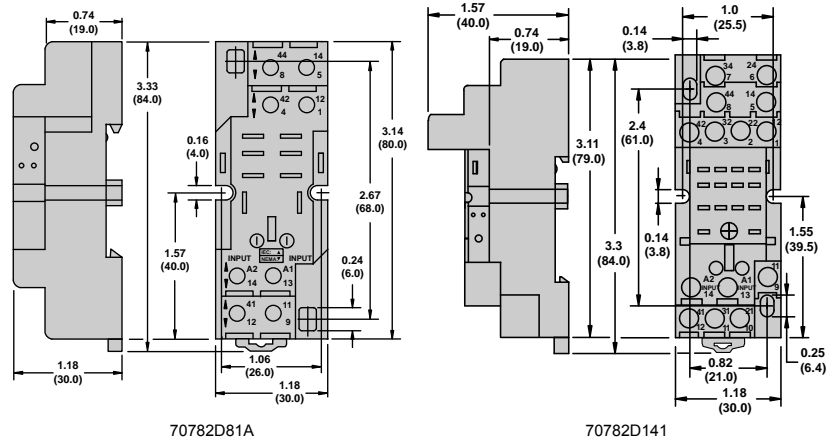

**Wiring Diagrams**

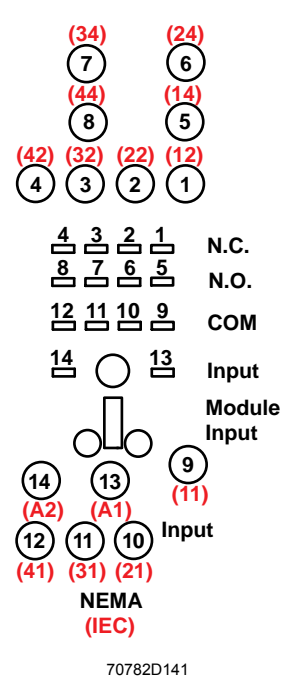
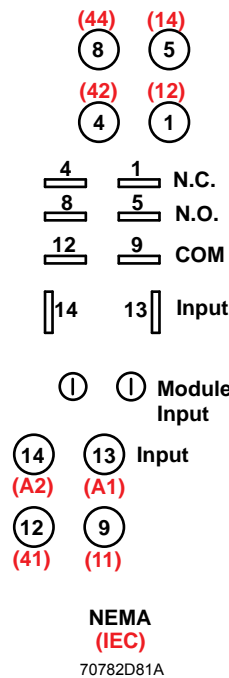

70782E141 and 70782EL81 Socket Specifications

Part Number		70782E141	70782EL81
Contact Configuration		4PDT	DPDT
Number of Terminals		14	8
Mounting Style		Panel or DIN rail	Panel or DIN rail
Current Rating		10 A	12 A
Nominal Voltage Rating		300 V	300 V
Temperature Range	Storage	-40 to +105°C (-40 to +221°F)	-40 to +105°C (-40 to +221°F)
	Operating	-40 to +70°C (-40 to +158°F)	-40 to +55°C (-40 to +131°F)
Protection Category		IP20	IP20
Internal Metal Tracks		Copper Alloy, Zinc Plated	Copper Alloy, Zinc Plated
Screw Terminals		Steel, Zinc Plated	Steel, Zinc Plated
Screw Style		Combination Head	Combination Head
Screw Size		M3 mm	M3.5 mm
Maximum Screw Torque		7 lb-in (0.8 N•m)	9 lb-in (1.0 N•m)
Terminal Connection		Elevator	Elevator
Terminal Layout		Separate	Separate
Maximum Wire Size	Solid Copper	Two 16–14 AWG (two 1.5–2.5 mm <sup>2</sup> )	Two 14–12 AWG (two 2.5–4 mm <sup>2</sup> )
	Stranded Copper	Two 16–14 AWG (two 1.5–2.5 mm <sup>2</sup> )	Two 14–12 AWG (two 2.5–4 mm <sup>2</sup> )
DIN Rail Mounting, EN 60715		35 mm	35 mm
Chassis Mount Screw Torque		7 lb-in (0.8 N•m)	7 lb-in (0.8 N•m)
Flammability Rating		94V-0	94V-0
Weight		56 g (1.98 oz)	46 g (1.62 oz)
Agency Approvals		UL (E70550) CE, CSA (LR40787), RoHS	UL (E70550), CE, CSA (LR40787), RoHS

Dimensions, in. (mm)

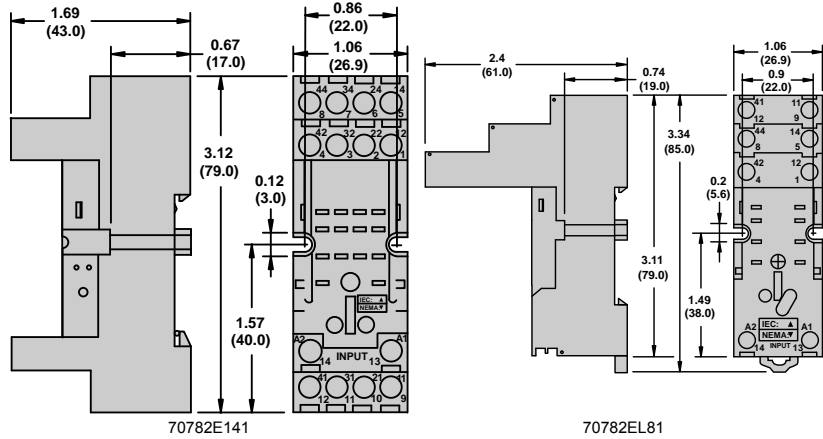

Wiring Diagrams

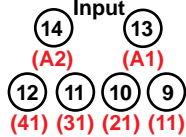
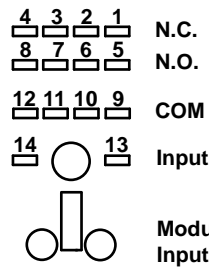

NEMA (IEC)

70782E141

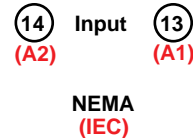
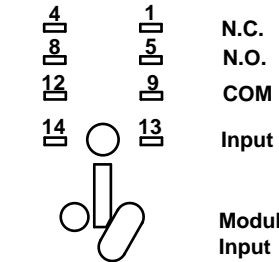
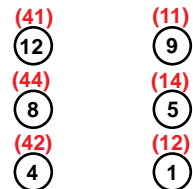

NEMA (IEC)

70782EL81

**70782EL141 Socket Specifications**

Part Number		70782EL141
Contact Configuration		4PDT
Number of Terminals		14
Mounting Style		Panel or DIN rail
Current Rating		10 A
Nominal Voltage Rating		300 V
Temperature Range	Storage	-40 to +105°C (-40 to +221°F)
	Operating	-40 to +70°C (-40 to +158°F)
Protection Category		IP20
Internal Metal Tracks		Copper Alloy, Zinc Plated
Screw Terminals		Steel, Zinc Plated
Screw Style		Combination Head
Screw Size		M3 mm
Maximum Screw Torque		7 lb-in (0.8 N•m)
Terminal Connection		Elevator
Terminal Layout		Separate
Maximum Wire Size	Solid Copper	Two 16–14 AWG (two 1.5–2.5 mm <sup>2</sup> )
	Stranded Copper	Two 16–14 AWG (two 1.5–2.5 mm <sup>2</sup> )
DIN Rail Mounting, EN 60715		35 mm
Chassis Mount Screw Torque		7 lb-in (0.8 N•m)
Flammability Rating		94V-0
Weight		62 g (2.19 oz)
Agency Approvals		UL (E70550), CE, CSA (LR40787), RoHS

**Dimensions, in, (mm)**

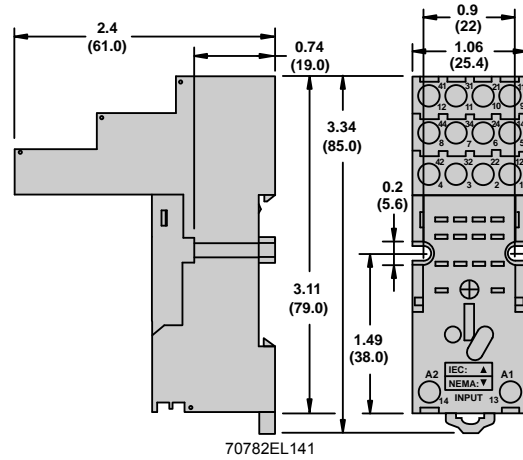

**Wiring Diagrams**

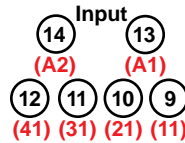
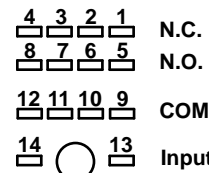

**NEMA (IEC)**  
70782EL141

70783D111A and 70784D141 Socket Specifications

Part Number		70783D111A	70784D141
Contact Configuration		3PDT	4PDT
Number of Terminals		11	14
Mounting Style		Panel or DIN rail	Panel or DIN rail
Current Rating		16 A	16 A
Nominal Voltage Rating		300 V	300 V
Temperature Range	Storage	-40 to +105°C (-40 to +221°F)	-40 to +105°C (-40 to +221°F)
	Operating	-40 to +55°C (-40 to +131°F)	-40 to +55°C (-40 to +131°F)
Protection Category		IP20	IP20
Internal Metal Tracks		Copper Alloy, Zinc Plated	Copper Alloy, Zinc Plated
Screw Terminals		Steel, Zinc Plated	Steel, Zinc Plated
Screw Style		Combination Head	Combination Head
Screw Size		M3.5 mm	M3.5 mm
Maximum Screw Torque		9 lb-in (1.0 N•m)	9 lb-in (1.0 N•m)
Terminal Connection		Screw Clamping	Screw Clamping
Terminal Layout		Mix	Mix
Maximum Wire Size	Solid Copper	Two 14–12 AWG (two 2.5–4 mm <sup>2</sup> )	Two 14–12 AWG (two 2.5–4 mm <sup>2</sup> )
	Stranded Copper	Two 14–12 AWG (two 2.5–4 mm <sup>2</sup> )	Two 14–12 AWG (two 2.5–4 mm <sup>2</sup> )
DIN Rail Mounting, EN 60715		35 mm	35 mm
Chassis Mount Screw Torque		7 lb-in (0.8 N•m)	7 lb-in (0.8 N•m)
Flammability Rating		94V-0	94V-0
Weight		55 g (1.94oz)	62 g (2.19 oz)
Agency Approvals		CE, RoHS, UL (E70550), CSA (LR40787)	CE, RoHS, UL (E70550), CSA (LR40787)

Dimensions, in, (mm)

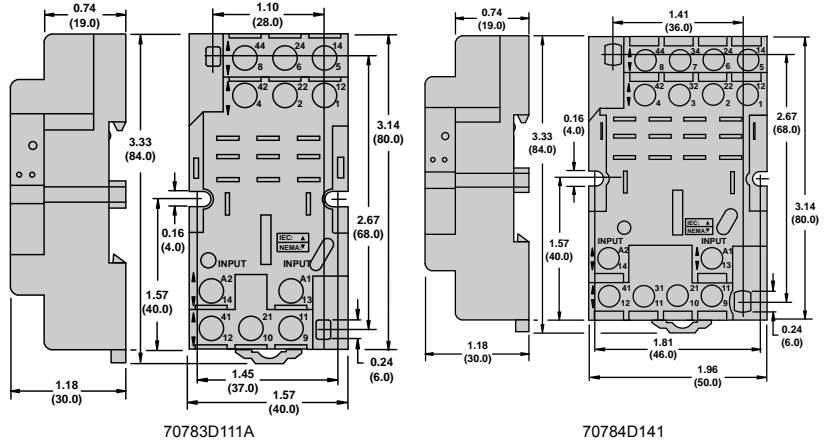

Wiring Diagrams

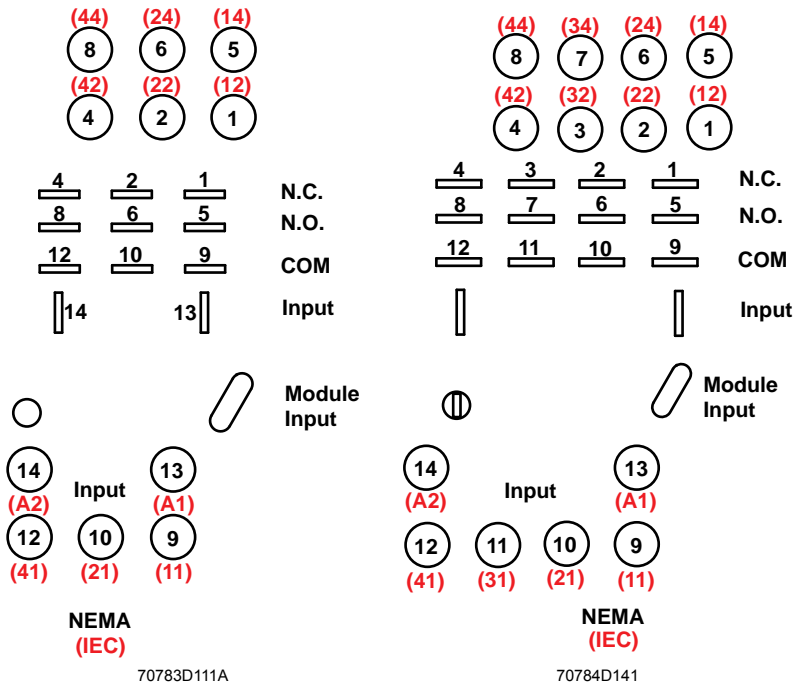

**70788EL111 Socket Specifications**

Part Number		70788EL111
Contact Configuration		3PDT
Number of Terminals		11
Mounting Style		DIN rail
Current Rating		25 A
Nominal Voltage Rating		300 V
Temperature Range	Storage	-40 to +105°C (-40 to +221°F)
	Operating	-40 to +55°C (-40 to +131°F)
Protection Category		IP20
Internal Metal Tracks		Copper Alloy, Zinc Plated
Screw Terminals		Steel, Zinc Plated
Screw Style		Combination Head
Screw Size		M3.5 mm
Maximum Screw Torque		9 lb-in (1.0 N•m)
Terminal Connection		Elevator
Terminal Layout		Separate
Maximum Wire Size	Solid Copper	Two 14–10 AWG (two 2.5–6 mm <sup>2</sup> )
	Stranded Copper	Two 14–10 AWG (two 2.5–6 mm <sup>2</sup> )
DIN Rail Mounting, EN 60715		35 mm
Chassis Mount Screw Torque		7 lb-in (0.8 N•m)
Flammability Rating		94V-0
Weight		96 g (3.39 oz)
Agency Approvals		UL (E70550), CE, CSA (LR40787), RoHS

**Dimensions, in, (mm)**

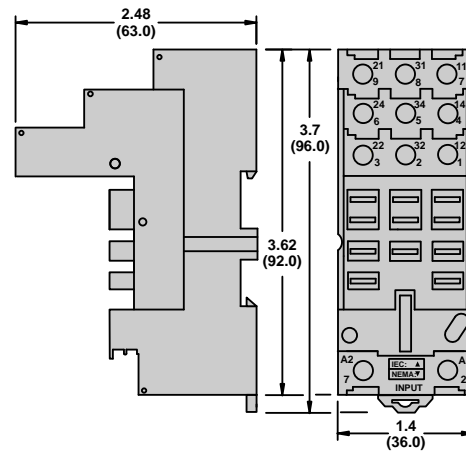

70788EL111

**Wiring Diagram**

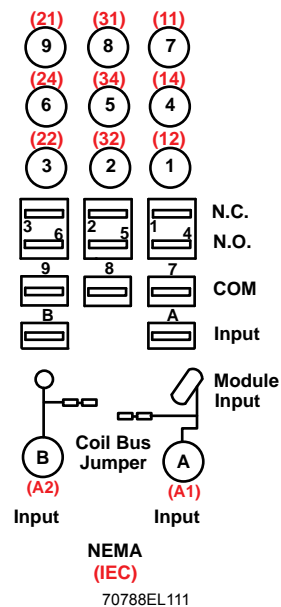



199 Series Relay

199 Power Relays

199—SPST-NO-DM, 40 A; SPDT, 40 A; DPST-NO, 40 A; DPDT, 40 A

Table 23.40: Standard Part Numbers

Rated Contact Current	Contact Configuration	Coil Voltage	Coil Resistance (Ω)	Special Features	Standard Part Number
40 A <sup>[24]</sup>	SPST-NO-DM	120 Vac	290		199ADX4
		12 Vdc	70		199DX2
		24 Vdc	290	Blowout Magnet	199DBX3
		48 Vdc	1200	Blowout Magnet	199DX3
	SPDT	120 Vac	290		199AX4
		12 Vdc	70		199X2
		24 Vdc	290		199X3
	DPST-NO	120 Vac	290		199AX9
		240 Vac	1200		199AX10
		12 Vdc	70		199X7
		24 Vdc	290		199X8
	DPDT	24 Vac	12		199AX13
		120 Vac	290	Blowout Magnet	199ABX14
					199AX14
		240 Vac	1200		199AX15
		12 Vdc	70	Blowout Magnet	199BX12
				199X12	
24 Vdc		290	Blowout Magnet	199BX13	
				199X13	
			Blowout Magnet	199BX14	
				199X14	

199 Specifications (UL 508)

Part Numbers	199AX, 199X, 199ABX <sup>[25]</sup> , 199BX	199ADX, 199DX, 199DYX, 199DBX <sup>[25]</sup>
<b>Contact Characteristics</b>		
Contact Configuration	SPST, SPDT, DPST, DPDT	SPST-DM, SPST-DB
Contact Material	Silver alloy	
Thermal (Carrying) Current	40 A	
Maximum Switching Voltage	600 V(rms)	
Rated Switching Current at Voltage	Resistive: 40 A at 300 Vac 50/60 Hz; 5 A at 480 Vac 50/60 Hz; 5 A at 600 Vac 50/60 Hz; 40 A at 28 Vdc	Resistive: 40 A at 300 Vac 50/60 Hz; 12 A at 480 Vac 50/60 Hz; 10 A at 600 Vac 50/60 Hz; 40 A at 28 Vdc
	Motor: 2 hp at 120–600 Vac 50/60 Hz	
	Tungsten: 15 A at 120 Vac 50/60 Hz	
	Pilot Duty: A600	
Minimum Switching Requirement	1 A at 5 Vac/Vdc	
<b>Coil Characteristics</b>		
Coil Voltage Range <sup>[26]</sup>	6–600 Vac 50/60 Hz; 6–250 Vdc	
Operating Range (% of Nominal)	85%–110% (AC); 80%–110% (DC)	
Average Consumption (Maximum)	10 VA (AC); 4 W (DC)	
Drop-Out Voltage Threshold	10% (AC/DC)	

Table 23.41: Additional DC Ratings with Blowout Magnet

Load Voltage	Contact Rating
110 Vdc	20 A
220 Vdc	8 A
325 Vdc	4 A
500 Vdc	2 A

Table 23.42: Auxiliary Switch Ratings (Non-Standard Option)

Load Type	Contact Rating
Resistive Load 120/250 Vac (50/60 Hz)	10 A
Motor Load 125/250 Vac (50/60 Hz)	0.25 hp
Tungsten Load 125 Vac (50/60 Hz)	3 A

[24] 50 A versions and additional options available. Call Customer Service for more information (847-441-2540).  
 [25] For ratings with blowout magnet, refer to Table 23.41 Additional DC Ratings with Blowout Magnet, page 23-48  
 [26] For available standard coil voltages, refer to Standard Part Numbers, page 23-48

**Table 23.43: Contact Ratings and Electrical Endurance (per IEC 60947-1, 60947-4)**

Contact Ratings	Load Voltage	Frequency	Load Type	Estimated Electrical Endurance	See Note(s)
<b>AC Load</b>					
40 A	300 V	50/60 Hz	Resistive	50,000 cycles	[27][28]
2 hp	120–600 V		Motor	50,000 cycles	[29][28]
15 A	120 V		Tungsten	20,000 cycles	[28][30]
A600	—		Pilot Duty	100,000 cycles	[28]
<b>DC Load</b>					
40 A	28 V	DC	Resistive	100,000 cycles	[28]
20 A	110 V				
8 A	220 V				
4 A	325 V				
2 A	500 V				

**Dimensions, in. (mm)**

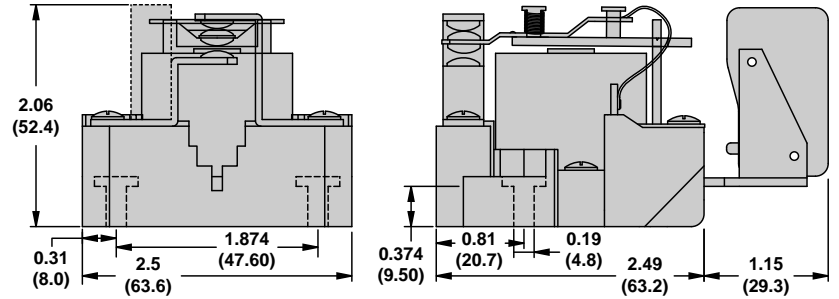

SPDT—Short Base (shown with optional Auxiliary Switch)

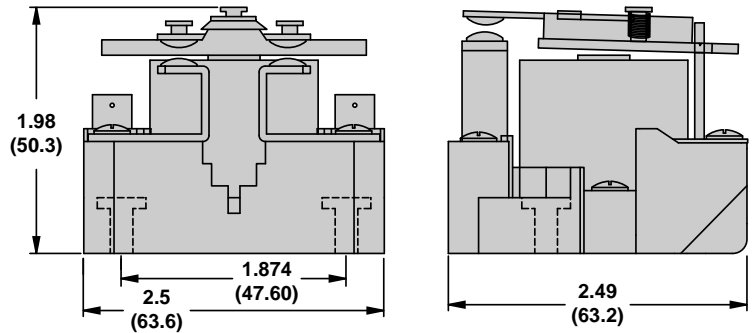

SPST-NO-DM

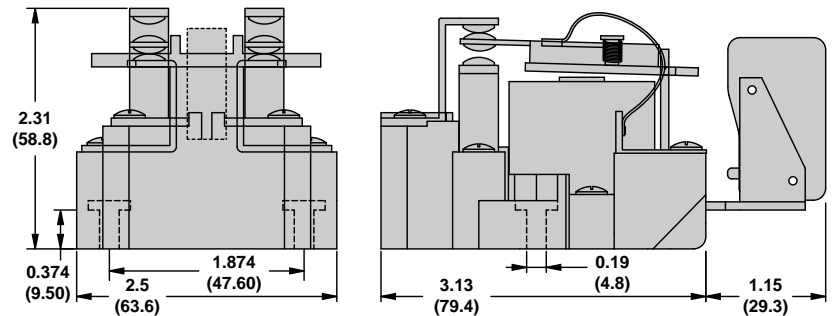

DPDT—Long Base (shown with optional Auxiliary Switch)

[27] Resistive AC load ratings are based on a power factor of 0.85–1.0.

[28] All ratings are based on applying the rated nominal power to the relay coil so as to provide a “clean” make and break that does not result in any contact chatter or multiple actuation of the contacts.

[29] Motor horsepower ratings are based on a power factor of 0.4–0.5, and an initial inrush current not exceeding

[30] The tungsten rating is based on cold-filament inrush current not exceeding 15 times the rated steady-state lamp current.

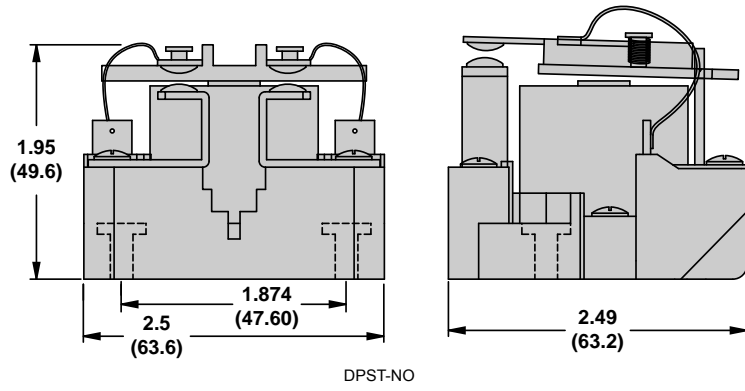

Wiring Diagrams

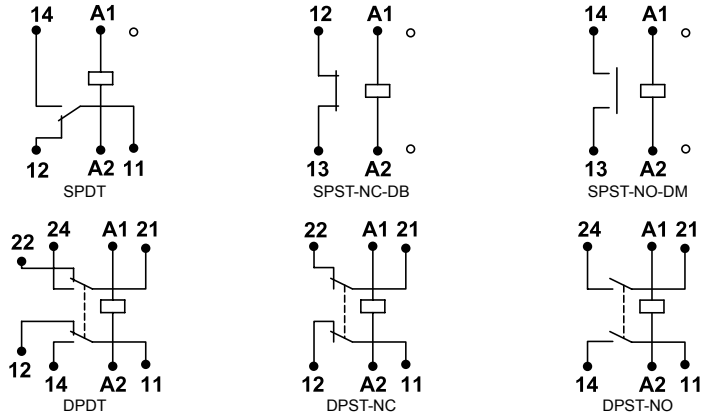



Plug-In Socket Mount with full feature cover



Panel/DIN Mount with blade terminals



Panel/DIN Mount with screw terminals

**725 Power Relays**  
725—SPST-NO, 30 A; DPST-NO, 25 A

**Table 23.44: Standard Coil Voltages**

Rated Contact Current	Contact Configuration	Coil Voltage	Coil Resistance (Ω)	Mounting Style	Terminal Style	Standard Part Number
25 A	DPST-NO	24 Vac	275	DIN and panel	Blade terminals	725BXXBC3ML24A
					Screw terminals	725BXXSC3ML24A
		120 Vac	5200	DIN and panel	Blade terminals	725BXXBC3ML120A
					Screw terminals	725BXXSC3ML120A
		240 Vac	21000	DIN and panel	Blade terminals	725BXXBC3ML240A
					Screw terminals	725BXXSC3ML240A
12 Vdc	75	DIN and panel	Blade terminals	725BXXBC3ML12D		
			Screw terminals	725BXXSC3ML12D		
24 Vdc	300	DIN and panel	Blade terminals	725BXXBC3ML24D		
			Screw terminals	725BXXSC3ML24D		
30 A	SPST-NO	24 Vac	275	DIN and panel	Blade terminals	725AXXBC3ML24A
					Screw terminals	725AXXSC3ML24A
		120 Vac	5200	DIN and panel	Blade terminals	725AXXBC3ML120A
					Screw terminals	725AXXSC3ML120A
		240 Vac	21000	DIN and panel	Blade terminals	725AXXBC3ML240A
					Screw terminals	725AXXSC3ML240A
		12 Vdc	75	DIN and panel	Blade terminals	725AXXBC3ML12D
					Screw terminals	725AXXSC3ML12D
		24 Vdc	300	DIN and panel	Blade terminals	725AXXBC3ML24D
					Screw terminals	725AXXSC3ML24D

**725 Specifications**

Part Number	725AXX	725BXX
<b>Contact Characteristics</b>		
Contact Configuration	SPST-NO	DPST-NO
Contact Material	Silver alloy	
Thermal (Carrying) Current	30 A	25 A
Maximum Switching Voltage	300 V	
Current Ratings at Voltage	Resistive: 30 A at 277 Vac 50/60 Hz, 6,000 cycles	Resistive: 25 A at 277 Vac 50/60 Hz; 25 A at 30 Vdc, 6,000 cycles
	Motor: 1.5 hp at 120 Vac 50/60 Hz; 3.0 hp at 277 Vac 50/60 Hz, 6,000 cycles	Motor: 1.0 hp at 120 Vac 50/60 Hz; 2.0 hp at 277 Vac 50/60 Hz, 6,000 cycles
	Tungsten: 1.5 kW at 120 Vac 50/60 Hz, 6,000 cycles	Tungsten: 1.3 kW at 120 Vac 50/60 Hz, 6,000 cycles
Minimum Switching Requirement	100 mA at 5 Vdc (0.5 W)	
<b>Coil Characteristics</b>		
Coil Voltage Range <sup>[31]</sup> Standard Coil Voltages, page 23-51	6–240 Vac 50/60 Hz (All AC coils are rectified); 6–110 Vdc <sup>[31]</sup> Standard Coil Voltages, page 23-51	
Operating Range (% of Nominal)	75%–110% (AC/DC)	
Average Consumption	2.5 VA (AC); 1.9 W (DC)	
Insulation System Per UL 508	Class B (130°C)	

[31] For available standard coil voltages, refer to the

Dimensions, in, (mm)

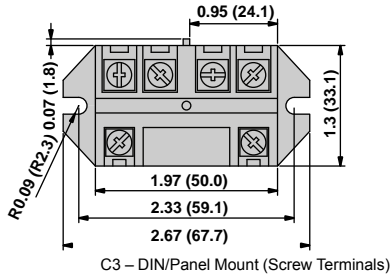
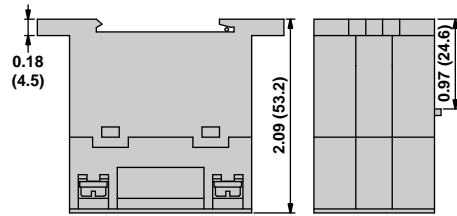
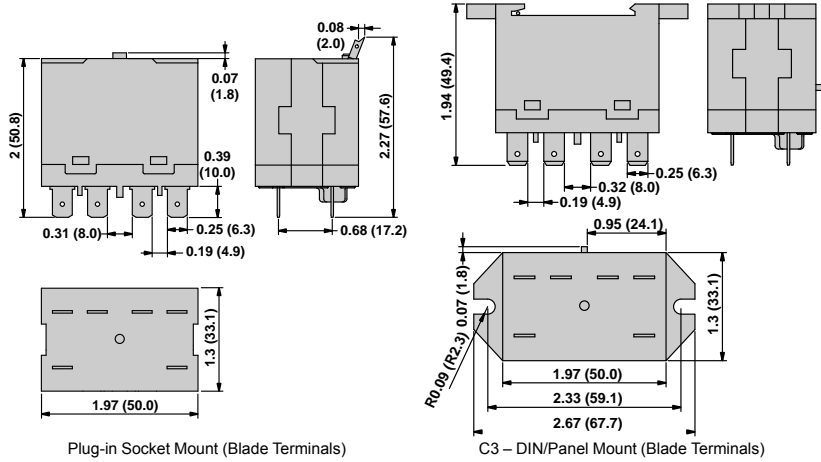

Wiring Diagrams

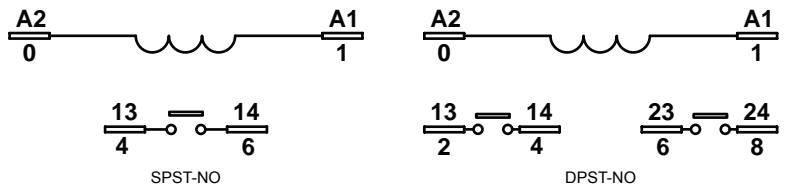

**389F Power Relays**

389F—SPST, 30 A; DPDT, 20–25 A; SPDT, 25–30 A; 3PDT, 20 A



Plug-In (Socket) Cover



Side Flange Cover

**Table 23.45: Standard Part Numbers**

Rated Contact Current	Contact Configuration	Coil Voltage	Coil Resistance (Ω)	Cover Style	Standard Part Number
20 A	3PDT	12 Vac	17.7	Side flange	389FXCXC112A
		24 Vac	72	Side flange	389FXCXC124A
				Plug-in (socket)	389FXCXC24A
		120 Vac	1700	Plug-in (socket)	389FXCXC120A
				Side flange	389FXCXC1120A
		240 Vac	7200	Plug-in (socket)	389FXCXC240A
Side flange	389FXCXC1240A				
25 A	DPDT	24 Vac	72	Plug-in (socket)	389FBXC24A
		120 Vac	1700	Side flange	389FBXC124A
				Plug-in (socket)	389FBXC120A
		240 Vac	7200	Side flange	389FBXC1120A
				Plug-in (socket)	389FBXC240A
		12 Vdc	100	Side flange	389FBXC112D
Plug-in (socket)	389FBXC24D				
24 Vdc	400	Side flange	389FBXC124D		
		Plug-in (socket)	389FBXC24D		
25 A	SPDT	24 Vac	72	Side flange	389FAXC124A
		120 Vac	1700	Side flange	389FAXC1120A
				Side flange	389FAXC1240A
		240 Vac	7200	Side flange	389FAXC1240A
				Side flange	389FAXC112D
		12 Vdc	100	Side flange	389FAXC124D
Side flange	389FAXC124D				
30 A	SPDT-DM-DB	24 Vac	72	Side flange	389FXHXC124A
		120 Vac	1700	Side flange	389FXHXC1120A
		240 Vac	7200	Side flange	389FXHXC1240A
		12 Vdc	100	Side flange	389FXHXC112D
	24 Vdc	400	Side flange	389FXHXC124D	
			Side flange	389FHXC124A	
SPST-NO-DM	24 Vac	72	Side flange	389FHXC1120A	
	120 Vac	1700	Side flange	389FHXC1120A	
	240 Vac	7200	Side flange	389FHXC1240A	
	12 Vdc	100	Side flange	389FHXC112D	
24 Vdc	400	Side flange	389FHXC124D		
		Side flange	389FHXC124D		

389F Specifications

23

RELAYS AND TIMERS

Part Number	389F XAX 389F XEX	389F XCX	389F XHX 389F HXX
<b>Contact Characteristics</b>			
Contact Configuration	SPDT; DPDT	3PDT	SPSTNODM; SPDTDMDB
Contact Material	Silver alloy		
Thermal (Carrying) Current	25 A	20 A	30 A
Maximum Switching Voltage	600 V	300 V	600 V
Rated Switching Current at Voltage (Conforming to IEC AC-1 and DC-1)	NO and NC: 25 A at 250 Vac NO and NC: 15 A at 28 Vdc	NO and NC: 20 A at 250 Vac NO and NC: 15 A at 28 Vdc	NO and NC: 30 A at 250 Vac NO and NC: 30 A at 28 Vdc
Current Ratings at Voltage (Conforming to UL)	Resistive: 25 A at 300 Vac 50/60 Hz; 5 A at 600 Vac 50/60 Hz; 13 A at 28 Vdc, 100,000 cycles  Motor: 1.5 hp at 200–240 Vac 50/60 Hz; 1 hp at 120–200 and 480–600 Vac <sup>[32]</sup> 50/60 Hz, 6,000 cycles  Pilot Duty: B600, 6,000 cycles  FLA/LRA: 22/98 A at 120 Vac, 6,000 cycles  Ballast: 20 A, 277 Vac 50/60 Hz, 6,000 cycles	Resistive: 20 A at 150 Vac 50/60 Hz, 15 A at 250 Vac, 50/60 Hz 13 A at 28 Vdc, 50,000 cycles  Motor: 0.5 hp at 120–240 Vac 50/60 Hz, 6,000 cycles  Pilot Duty: B300, 6,000 cycles  Ballast: 20 A, 150 Vac 50/60 Hz 6.67 A at 277 Vac 6,000 cycles	Resistive: 30 A at 300 Vac 50/60 Hz 10 A at 600 Vac 50/60 Hz 30 A at 28 Vdc, 100,000 cycles  Motor: 1.5 hp at 200–600 Vac 50/60 Hz; 1 hp at 120–200 Vac 50/60 Hz, 6,000 cycles  Pilot Duty: A600, 6,000 cycles  FLA/LRA: 22/98 A at 120 Vac, 6,000 cycles; 17/60 A at 300 Vac, 6,000 cycles <sup>[32]</sup>  Ballast: 25 A, 277 Vac 50/60 Hz, 6,000 cycles
Minimum Switching Requirement	100 mA at 5 Vdc		
<b>Coil Characteristics</b>			
Coil Voltage Range <sup>[33]</sup> Table 23.45 Standard Part Numbers, page 23-53	12–240 Vac 50/60 Hz; 12–24 Vdc <sup>[33]</sup> Table 23.45 Standard Part Numbers, page 23-53		
Operating Range (% of Nominal)	85%–110% (AC); 80%–110% (DC)		
Average Consumption	2 VA (AC); 1.5 W (DC)		
Drop-out Voltage Threshold	10% minimum (AC/DC)		
<b>General Characteristics</b>			
Electrical Life at Rated Load <sup>[34]</sup>	100,000 operations for IEC AC-1, 50,000 operations for IEC DC-1		
Mechanical Life at No Load (Unpowered)	5,000,000 operations		
Operate Time at Nominal Coil Voltage	20 ms (maximum)		
Dielectric Strength	Between coil and contact: 2200 Vac; between poles: 2200 Vac; between contacts: 1600 Vac		
Operating Temperature Range	-30 to +55°C (-22 to +131°F)		
Storage Temperature Range	-30 to +85°C (-22 to +185°F)		
Weight (Average)	84 g (3.0 oz)		
Product Certifications	UL (E164862), CE (per IEC 60947), CSA (File: 044087 Class: 3211-07), RoHS		

Dimensions, in. (mm)

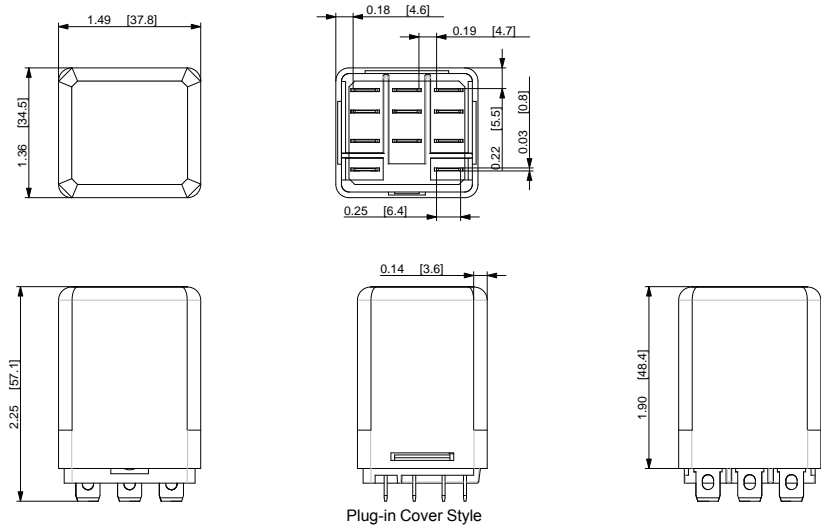

[32] Break all lines for 1 hp at 600 Vac, 50/60 Hz.  
 [33] For available standard coil voltages, refer to the  
 [34] The NO and NC contacts were tested independently

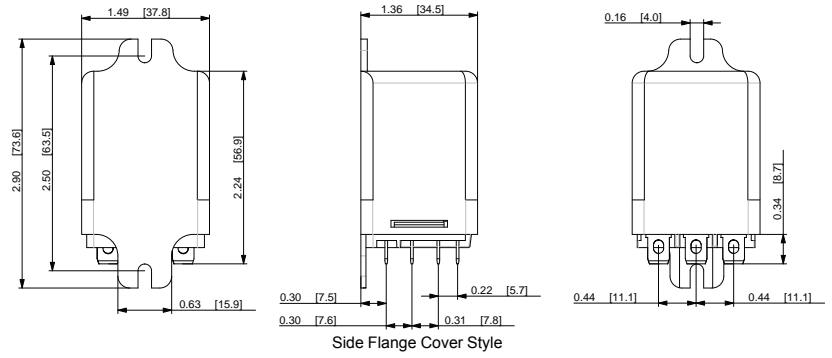

**Wiring Diagrams**

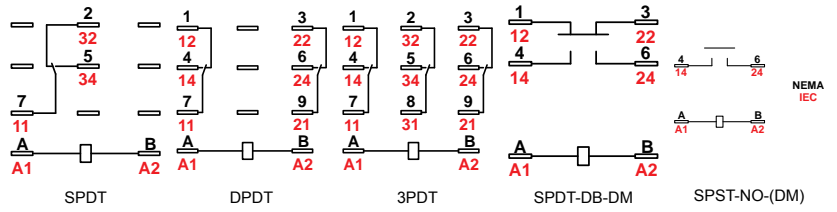



Top DIN Mount Cover



Side Flange Cover

300 Power Relays  
300—DPDT, 30 A

Table 23.46: Standard Part Numbers

Rated Contact Current	Contact Configuration	Coil Voltage	Coil Resistance (Ω)	Cover Style	Standard Part Number
30 A	DPDT	12 Vac	13.5	Side flange mount	300XBXC112A
		24 Vac	54	Side flange mount	300XBXC124A
		120 Vac	1270	Side flange mount	300XBXC1120A
		240 Vac	5400	Side flange mount	300XBXC1240A
		12 Vdc	57	Side flange mount	300XBXC112D
		24 Vdc	300	Side flange mount (with magnetic blowout)	300XBXC124D

300 Specifications

Part Number	300XBXC [35]
<b>Contact Characteristics</b>	
Contact Configuration	DPDT
Contact Material	Silver alloy
Thermal (Carrying) Current	30 A
Maximum Switching Voltage	600 V
Current Ratings at Voltage <sup>[35]</sup>	Resistive: 30 A at 300 Vac 50/60 Hz; 30 A at 28 Vdc; 15 A at 600 Vac 50/60 Hz Motor: 1 hp at 120 Vac 50/60 Hz; 6,000 cycles; 2 hp at 208–600 Vac 50/60 Hz <sup>[36]</sup> ; 6,000 cycles Pilot Duty: 5.5 A at 120 Vac 50/60 Hz, 6,000 cycles; 1.2 A at 600 Vac 50/60 Hz, 6,000 cycles
Minimum Switching Requirement	500 mA at 5 Vdc
<b>Coil Characteristics</b>	
Coil Voltage Range <sup>[37]</sup>	12–240 Vac 50/60 Hz; 12–24 Vdc
Operating Range (% of Nominal)	85%–110% (AC); 80%–110% (DC)
Average Consumption	3.4 VA (AC at 60 Hz); 2.3 W (DC)
Drop-out Voltage Threshold	15% (AC); 10% (DC)
<b>General Characteristics</b>	
Electrical Life at Rated Load	6,000 operations
Mechanical Life at No Load (Unpowered)	5,000,000 operations
Operate Time at Nominal Coil Voltage	20 ms
Dielectric Strength	Between coil and contact: 4000 Vac; Between poles: 2500 Vac; Between contacts: 2500 Vac
Operating Temperature Range	–40 to +55°C (–40 to +131°F)
Storage Temperature Range	–40 to +85°C (–40 to +185°F)
Weight (Average)	without blowout magnet: 85 g (3.0 oz) with blowout magnet: 95 g (3.4 oz)
Product Certifications	UL (E164862), CSA (File: 044087 Class: 3211-07), RoHS

Table 23.47: Additional DC Ratings with Blowout Magnet

Load Voltage	Contact Reading
150 Vdc	5 A

[35] For additional ratings with blowout magnet, refer to Table 23.47 Additional DC Ratings with Blowout Magnet, page 23-56

[36] Break all lines for 2 hp / 480–600 Vac, 50/60 Hz.

[37] For available standard coil voltages, refer to Table 23.46 Standard Part Numbers, page 23-56

**Dimensions, in, (mm)**

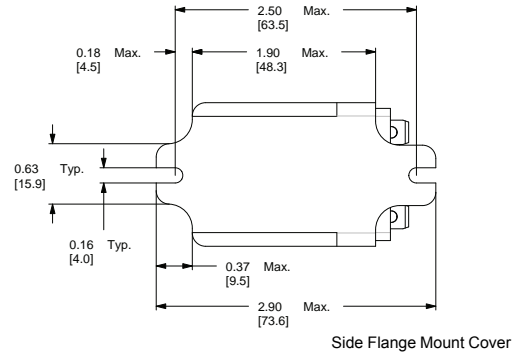
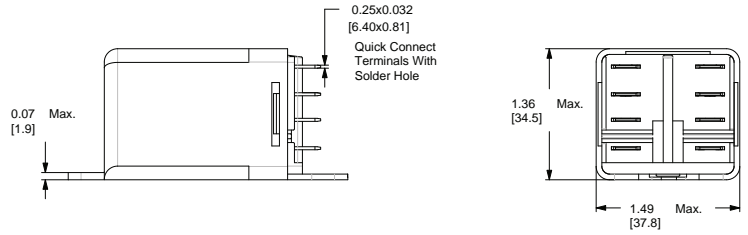

**Wiring Diagrams**

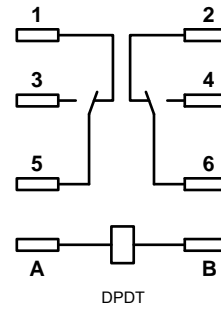



92S7A22D24

92 Power Relays

92—DPST-NO, 30 A; DPDT, 30 A (NO) / 3 A (NC)

Table 23.48: Standard Part Numbers

Rated Contact Current	Contact Configuration	Coil Voltage	Coil Resistance (Ω)	Standard Part Number
30 A	DPST-NO	24 Vac	170 <sup>[38]</sup>	92S7A22D24
		120 Vac	4250 <sup>[38]</sup>	92S7A22D120
		240 Vac	16500 <sup>[38]</sup>	92S7A22D240
		12 Vdc	86	92S7D22D12
		24 Vdc	350	92S7D22D24
30 A (NO) / 3 A (NC)	DPDT	24 Vac	170 <sup>[38]</sup>	92S11A22D24
		120 Vac	4250 <sup>[38]</sup>	92S11A22D120
		240 Vac	16500 <sup>[38]</sup>	92S11A22D240
		12 Vdc	86	92S11D22D12
		24 Vdc	350	92S11D22D24

92 Specifications

Part Number	92S7	92S11
<b>Contact Characteristics</b>		
Contact Configuration	DPST-NO	DPDT
Contact Material	Silver alloy	
Thermal (Carrying) Current	30 A	30 A (NO); 3 A (NC)
Maximum Switching Voltage (Conforming to IEC)	250 Vac / 28 Vdc	
Maximum Switching Voltage (Conforming to UL)	300 Vac / 28 Vdc	
Current Ratings at Voltage (Conforming to IEC)	(NO) 30 A at 250 Vac; 25 A at 28 Vdc, 100,000 cycles	(NO) 30 A at 250 Vac; 25 A at 28 Vdc, 100,000 cycles (NC) 3 A at 250 Vac; 3 A at 28 Vdc, 100,000 cycles
Current Ratings at Voltage (Conforming to UL)	(NO) General Use: 30 A at 277 Vac, 100,000 cycles Resistive: 20 A at 28 Vdc, 100,000 cycles Motor: 1.0 hp at 120 Vac; 3.0 hp at 240 Vac, 100,000 cycles LRA/FLA : 96 A / 22 A @ 240 Vac (AC coil), 30,000 cycles; 110 A / 25.3 A @ 240 Vac (DC coil), 30,000 cycles Pilot Duty: 720 VA / A300, 6,000 cycles Short Circuit: 5000 A(rms) @ 240 Vac Tungsten: 10 A at 120 Vac 50/60 Hz, 25,000 cycles; 6 A at 250 Vac 50/60 Hz, 25,000 cycles	(NO) General Use: 30 A at 277 Vac, 100,000 cycles Resistive: 20 A at 28 Vdc, 100,000 cycles Motor: 1.0 hp at 120 Vac; 3.0 hp at 240 Vac, 100,000 cycles LRA/FLA : 96 A / 22 A @ 240 Vac (AC coil), 30,000 cycles; 110 A / 25.3 A @ 240 Vac (DC coil), 30,000 cycles Pilot Duty: 720 VA / A300, 6,000 cycles Short Circuit: 5000 A(rms) @ 240 Vac Tungsten: 10 A at 120 Vac 50/60 Hz, 25,000 cycles; 6 A at 250 Vac 50/60 Hz, 25,000 cycles (NC) Resistive: 3 A at 277 Vac 6,000 cycles; 3 A at 28 Vdc 100,000 cycles
Switching Capacity	Maximum: 7500 VA / 840 W (when mounted with 13 mm gap between 2 relays); 6250 VA / 700 W (when mounted side by side without a gap) Minimum: 170 mW	
Minimum Switching Requirements	10 mA at 17 V	
<b>Coil Characteristics</b>		
Coil Voltage Range <sup>[39]</sup>	12–240 Vac <sup>[38]</sup> 50/60 Hz; 12–24 Vdc	
Operating Range (% of Nominal)	80%–110%	
Average Consumption	4 VA –20% / +10% (AC); 1.7 W –20% / +10% (DC)	
Drop-out Voltage Threshold	15% minimum (AC); 10% minimum (DC)	

[38] All AC coils are rectified.

[39] For available standard coil voltages, refer to the Table 23.48 Standard Part Numbers, page 23-58

**Dimensions, in, (mm)**

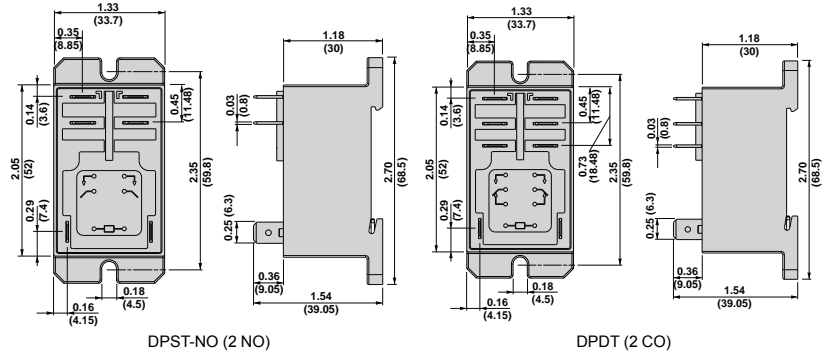

**Wiring Diagrams**

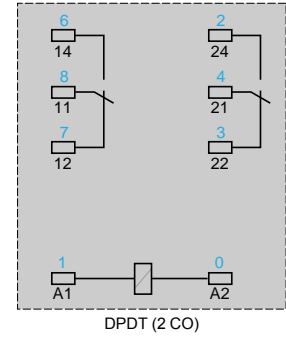
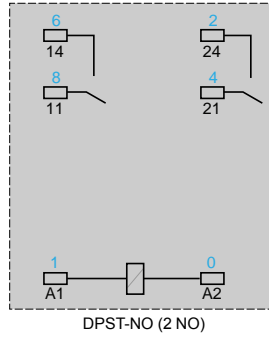

*New!*

**Square D™ Universal Relays**

8501K relays are designed for multipole switching applications at 240 Vac or lower. These relays have industry standard wiring and pin terminal arrangements which allow for their use as replacements for many competitive relays without wiring or hardware modifications.

- 10 A relays
- DPDT or 3PDT
- Green pilot light option
- Motor load (hp) ratings
- DPDT latching models available
- AC or DC operation
- RoHS Compliant



8501KPDR12V60



8501KFR13V20



8501KUDR12P14V60



8501NR61

**Table 23.49: Relays: Standard Cover, without LED**

Pins	Coil Voltage	Number and Type of Contacts - Thermal current (Ith)	
		DPDT (2 C/O) - 10 A	3PDT (3 C/O) - 10 A
		Catalog Number	Catalog Number
Octal	12 Vdc	8501KPDR12V51	8501KPDR13V51
	24 Vdc	8501KPDR12V53	8501KPDR13V53
	48 Vdc	8501KPDR12V56	8501KPDR13V56
	110 Vdc	8501KPDR12V60	8501KPDR13V60
	24 Vac	8501KPR12V14	8501KPR13V14
	120 Vac	8501KPR12V20	8501KPR13V20
Blade	240 Vac	8501KPR12V24	8501KPR13V24
	12 Vdc	8501KUDR12V51	8501KUDR13V51
	24 Vdc	8501KUDR12V53	8501KUDR13V53
	48 Vdc	8501KUDR12V56	8501KUDR13V56
	110 Vdc	8501KUDR12V60	8501KUDR13V60
	24 Vac	8501KUR12V14	8501KUR13V14
	120 Vac	8501KUR12V20	8501KUR13V20
	240 Vac	8501KUR12V24	8501KUR13V24

**Table 23.50: Relays: Flange Mount Cover**

Pins	Coil Voltage	Number and Type of Contacts - Thermal current (Ith)	
		DPDT (2 C/O) - 10 A	3PDT (3 C/O) - 10 A
		Catalog Number	Catalog Number
Blade	12 Vdc	8501KFDR12V51	8501KFDR13V51
	24 Vdc	8501KFDR12V53	8501KFDR13V53
	48 Vdc	8501KFDR12V56	8501KFDR13V56
	110 Vdc	8501KFDR12V60	8501KFDR13V60
	24 Vac	8501KFR12V14	8501KFR13V14
	120 Vac	8501KFR12V20	8501KFR13V20
	240 Vac	8501KFR12V24	8501KFR13V24



8501NR52



8501NR82

**Table 23.51: Relays: Standard Cover, with LED**

Pins	Coil Voltage	Number and Type of Contacts - Thermal current (Ith)	
		DPDT (2 C/O) - 10 A	3PDT (3 C/O) - 10 A
		Catalog Number	Catalog Number
Octal	12 Vdc	8501KPDR12P14V51	8501KPDR13P14V51
	24 Vdc	8501KPDR12P14V53	8501KPDR13P14V53
	48 Vdc	8501KPDR12P14V56	8501KPDR13P14V56
	110 Vdc	8501KPDR12P14V60	8501KPDR13P14V60
	24 Vac	8501KPR12P14V14	8501KPR13P14V14
	120 Vac	8501KPR12P14V20	8501KPR13P14V20
Blade	240 Vac	8501KPR12P14V24	8501KPR13P14V24
	12 Vdc	8501KUDR12P14V51	8501KUDR13P14V51
	24 Vdc	8501KUDR12P14V53	8501KUDR13P14V53
	48 Vdc	8501KUDR12P14V56	8501KUDR13P14V56
	110 Vdc	8501KUDR12P14V60	8501KUDR13P14V60
	24 Vac	8501KUR12P14V14	8501KUR13P14V14
	120 Vac	8501KUR12P14V20	8501KUR13P14V20
	240 Vac	8501KUR12P14V24	8501KUR13P14V24



8501NR52 Socket  
+8501KPR13P14V2 Relay



8501NR82 Socket  
+8501KUDR12P14V Relay

**Table 23.52: Sockets**

Contact Terminal Arrangement	Connection	For Use with Relays	Sold in Lots of	Catalog Number <sup>[1]</sup>
Mixed	Screw Connector	8501KPR12*** 8501KPDR12***	1	8501NR51
		8501KPR12*** 8501KPDR12***	10	8501NR51B
		8501KPR13*** 8501KPDR13***	1	8501NR61
		8501KPR13*** 8501KPDR13***	10	8501NR61B
		8501KPR12*** 8501KPDR12***	1	8501NR52
Separate	Screw Connector	8501KPR12*** 8501KPDR12***	10	8501NR52B
		8501KPR13*** 8501KPDR13***	1	8501NR62
		8501KPR13*** 8501KPDR13***	10	8501NR62B
		8501KUR12*** 8501KUDR12***	1	8501NR82
		8501KUR12*** 8501KUDR12***	10	8501NR82B
		8501KUR13*** 8501KUDR13***	1	8501NR82

[1] Please note that the B suffix only designates quantities of 10 and is not printed on the socket.

**Table 23.52 Sockets (cont'd.)**

Contact Terminal Arrangement	Connection	For Use with Relays	Sold in Lots of	Catalog Number <sup>[2]</sup>
		8501KUR13... 8501KUDR13...	10	8501NR82B

**Table 23.53: Accessories (Sold in Lots of 10)**

Description	For Use With	Sold in Lots of	Catalog Number
Metal Restraining Strap	8501NR51 sockets	1	8501NH7
	8501NR52 sockets		
	8501NR62 sockets		
	8501NR82 sockets		
Metal Hold-Down Clip	8501NR52 sockets	10	8501NH52
	8501NR62 sockets		8501NH82
	8501NR82 sockets		

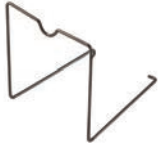

**Approvals for 8501 KPR, KUR, and KFR Relays**



File: E3190  
CCN: NLDX,  
NLDX7<sup>[2]</sup>



File: E3190  
CCN:  
NLDX2,  
NLDX8



File:  
260367  
Class:  
3211 07



RoHS  
Compliant

**Approvals for 8501NR Sockets**



File: E66924  
CCN: SWIV2,  
SWIV8



File: 211268  
Class: 3211 07



RoHS  
Compliant

<sup>[2]</sup> Please note that the B suffix only designates quantities of 10 and is not printed on the socket.

<sup>[2]</sup> When used with the appropriate 8501NR socket.



8501RS41P14V20



8501RSD42P14V51



8501RS43P14V20



8501RS44P14V20



8501NR41 Socket  
+8501RS41P14V20 Relay



8501NR42 Socket  
+8501RSD42P14V51 Relay



8501NR43 Socket  
+8501RS43P14V20 Relay



8501NR34 Socket  
+8501RS44P14V20 Relay

### Square D™ Plug-in Relays

8501R miniature plug-in relays have a 15 A resistive rating. The compact size of these relays makes them ideal for downsizing equipment and applications where space is at a premium.

- SPDT through 4PDT
- AC or DC operated
- Horsepower rated
- Socket compatible
- Green LED pilot light option
- Silver alloy contacts

Table 23.54: Relays: Standard Cover, without LED

Coil Voltage	Number and Type of Contacts - Thermal current (lth)			
	SPDT (1 C/O) - 15 A Catalog Number	DPDT (2 C/O) - 15 A Catalog Number	3PDT (3 C/O) - 15 A Catalog Number	4PDT (4 C/O) - 15 A Catalog Number
12 Vdc	8501RSD41V51	8501RSD42V51	8501RSD43V51	8501RSD44V51
24 Vdc	8501RSD41V53	8501RSD42V53	8501RSD43V53	8501RSD44V53
110 Vdc	8501RSD41V60	8501RSD42V60	8501RSD43V60	8501RSD44V60
12 Vac	8501RS41V36	8501RS42V36	8501RS43V36	8501RS44V36
24 Vac	8501RS41V14	8501RS42V14	8501RS43V14	8501RS44V14
120 Vac	8501RS41V20	8501RS42V20	8501RS43V20	8501RS44V20
240 Vac	8501RS41V24	8501RS42V24	8501RS43V24	8501RS44V24

Table 23.55: Relays: Standard Cover, with LED

Coil Voltage	Number and Type of Contacts - Thermal current (lth)			
	SPDT (1 C/O) - 15 A Catalog Number	DPDT (2 C/O) - 15 A Catalog Number	3PDT (3 C/O) - 15 A Catalog Number	4PDT (4 C/O) - 15 A Catalog Number
12 Vdc	8501RSD41P14V51	8501RSD42P14V51	8501RSD43P14V51	8501RSD44P14V51
24 Vdc	8501RSD41P14V53	8501RSD42P14V53	8501RSD43P14V53	8501RSD44P14V53
110 Vdc	8501RSD41P14V60	8501RSD42P14V60	8501RSD43P14V60	8501RSD44P14V60
12 Vac	8501RS41P14V36	8501RS42P14V36	8501RS43P14V36	8501RS44P14V36
24 Vac	8501RS41P14V14	8501RS42P14V14	8501RS43P14V14	8501RS44P14V14
120 Vac	8501RS41P14V20	8501RS42P14V20	8501RS43P14V20	8501RS44P14V20
240 Vac	8501RS41P14V24	8501RS42P14V24	8501RS43P14V24	8501RS44P14V24

Table 23.56: Sockets

Contact Terminal Arrangement	Connection	For Use with Relays	Sold in Lots of	Catalog Number <sup>[3]</sup>
Separate <sup>[4]</sup>	Screw Connector	8501RS41***	1	8501NR41
		8501RSD41***	10	8501NR41B
		8501RS42***	1	8501NR42
		8501RSD42***	10	8501NR42B
		8501RS43***	1	8501NR43
		8501RSD43***	10	8501NR43B
		8501RS44***	1	8501NR34
		8501RSD44***	10	8501NR34B

Table 23.57: Accessories (Sold in Lots of 10)

Description	For Use With	Sold in Lots of	Catalog Number
Plastic ID Clip	8501NR41 socket	Supplied with socket	—
	8501NR42 socket		
Metal Hold-Down Clip	8501NR43 socket	10	8501NH42
	8501NR34 socket		

#### Approvals for 8501 RS41, RSD41, RS42, RSD42, RS43, RSD43, RS44, and RSD44



File: E3190  
CCN: NLDX,  
NLDX7<sup>[5]</sup>



File: E3190  
CCN:  
NLDX2,  
NLDX8



File:  
260367  
Class:  
3211 07



IEC  
61810-1  
RoHS  
Compliant

#### Approvals for 8501NR Sockets



File: E66924  
CCN: SWIV2,  
SWIV8



File: 211268  
Class: 3211 07



IEC  
61810-1  
RoHS  
Compliant

[3] Please note that the B suffix only designates quantities of 10 and is not printed on the socket.

[4] The inputs and outputs are on separate sides.

[5] When used with the appropriate 8501NR socket.

**Square D™ Miniature Control Relays**

8501R relays are suited for use as logic elements and power switching output devices. The short stroke motion of the armature provides long mechanical life required for high speed operation of control systems. Different contact compositions allow these relays to be used in a variety of applications. Bifurcated crossbar (gold overlay silver) is suitable for high contact reliability and low level switching requirements. Silver alloy is best suited for inductive loads. Class I Division II sealed relays can be used in specified hazardous locations.

- 4PDT
- Complete socket line
- Horsepower rated
- AC or DC operation
- Green pilot light option



8501NR45 Socket  
+8501RS14V20 Relay



8501RS14V14



8501RSD24P14V60



8501RSD34V51

**Table 23.58: Relays: Standard Cover, without LED**

Coil Voltage	Number and Type of Contacts — Thermal current (Ith)	
	4PDT (4 C/O) — 6 A	4PDT (4 C/O) — 3 A
	Catalog Number	Catalog Number
12 Vdc	8501RSD14V51	8501RSD24V51
24 Vdc	8501RSD14V53	8501RSD24V53
48 Vdc	8501RSD14V56	8501RSD24V56
110 Vdc	8501RSD14V60	8501RSD24V60
24 Vac	8501RS14V14	8501RS24V14
120 Vac	8501RS14V20	8501RS24V20
240 Vac	8501RS14V24	8501RS24V24

**Table 23.59: Relays: Standard Cover, with LED**

Coil Voltage	Number and Type of Contacts — Thermal current (Ith)	
	4PDT (4 C/O) — 6 A	4PDT (4 C/O) — 3 A
	Catalog Number	Catalog Number
12 Vdc	8501RSD14P14V51	8501RSD24P14V51
24 Vdc	8501RSD14P14V53	8501RSD24P14V53
48 Vdc	8501RSD14P14V56	8501RSD24P14V56
110 Vdc	8501RSD14P14V60	8501RSD24P14V60
24 Vac	8501RS14P14V14	8501RS24P14V14
120 Vac	8501RS14P14V20	8501RS24P14V20
240 Vac	8501RS14P14V24	8501RS24P14V24

**Table 23.60: Relays: Hermetically Sealed Miniature Control Relays**

Coil Voltage	Number and Type of Contacts — Thermal current (Ith)	
	4PDT (4 C/O) — 5 A	
	Catalog Number	
6 Vdc	8501RSD34V50	
12 Vdc	8501RSD34V51	
24 Vdc	8501RSD34V53	
48 Vdc	8501RSD34V56	
110 Vdc	8501RSD34V60	
6 Vac	8501RS34V35	
12 Vac	8501RS34V36	
24 Vac	8501RS34V14	
48 Vac	8501RS34V17	
110 Vac	8501RS34V20	
240 Vac	8501RS34V24	



8501NR45



8501NH45

**Table 23.61: Sockets**

Contact Terminal Arrangement	Connection	For Use With Relays	Sold in Lots of	Catalog Number <sup>[6]</sup>
Separate <sup>[7]</sup>	Screw Clamp Terminals	8501RS(D)14***	1	8501NR45
		8501RS(D)24***		
		8501RS(D)34***		
	Spring Clamp Terminals	8501RS(D)14***	10	8501NR45B
		8501RS(D)24***		
		8501RS(D)34***		
		8501RS(D)14***	10	RXZE2S114S
	8501RS(D)24***			
	8501RS(D)34***			

**Table 23.62: Accessories (Sold in Lots of)**

Description	For Use With	Sold in Lots of	Catalog Number
Metal hold-down clip	8501NR45 socket	10	8501NH45
Clip-in ID tags	RXZE2S114S socket	10	RSZL300

**Approvals for 8501 RS14, RSD14, RS24, and RSD24 Relays**



File: E3190  
CCN: NLDX,  
NLDX7<sup>[8]</sup>



File: E3190  
CCN:  
NLDX2,  
NLDX8



File:  
260367  
Class:  
3211 07



RoHS  
Compliant

**Approvals for 8501 RS34 and RSD34 Relays**



File: E123950  
CCN: NLDX,  
NLDX7<sup>[8]</sup>  
ANSI/ISA  
12.12.01



File:  
E196809  
CCN:  
NQMJ2,  
NQMJ8



File:  
211268  
Class:  
3218 06



RoHS  
Compliant

**Approvals for 8501NR Sockets**



File: E66924  
CCN: SWIV2,  
SWIV8



File: 211268  
Class: 3211 07



RoHS  
Compliant

[6] Please note that the B suffix only designates quantities of 10 and is not printed on the socket.

[7] The inputs and outputs are on separate sides.

[8] When used with the appropriate 8501NR socket.



8501CDO6V51

**Square D™ Power Relays**

8501C relays are ideally suited for controlling single-phase motors, electric heaters, pumps, conveyors, material handling equipment, and other applications.

- 40 A contact rating
- Motor load (hp) ratings
- Durable open-frame construction
- UL Listed
- CSA certified
- CE approved
- RoHS compliant

**Table 23.63: Relays: AC Rated Contacts, 40 A at 277 V (sold in lots of 1)**

Coil Voltage	Number and type of contacts - Thermal current (lth)				
	SPST: 1 NO / 0 NC	DPST: 2 NO / 0 NC	SPST: 0 NO / 1 NC	SPDT: 1 NO / 1 NC	DPDT: 2 NO / 2 NC
	Catalog Number	Catalog Number	Catalog Number	Catalog Number	Catalog Number
6 Vdc	8501CDO6V50	8501CDO7V50	8501CDO8V50	8501CDO15V50	8501CDO16V50
12 Vdc	8501CDO6V51	8501CDO7V51	8501CDO8V51	8501CDO15V51	8501CDO16V51
24 Vdc	8501CDO6V53	8501CDO7V53	8501CDO8V53	8501CDO15V53	8501CDO16V53
110 Vdc	8501CDO6V60	8501CDO7V60	8501CDO8V60	8501CDO15V60	8501CDO16V60
6 Vac	8501CO6V35	8501CO7V35	8501CO8V35	8501CO15V35	8501CO16V35
12 Vac	8501CO6V36	8501CO7V36	8501CO8V36	8501CO15V36	8501CO16V36
24 Vac	8501CO6V14	8501CO7V14	8501CO8V14	8501CO15V14	8501CO16V14
120 Vac	8501CO6V20	8501CO7V20	8501CO8V20	8501CO15V20	8501CO16V20
208 Vac	8501CO6V08	8501CO7V08	8501CO8V08	8501CO15V08	8501CO16V08
240 Vac	8501CO6V24	8501CO7V24	8501CO8V24	8501CO15V24	8501CO16V24
277 Vac	8501CO6V04	8501CO7V04	8501CO8V04	8501CO15V04	8501CO16V04
480 Vac	8501CO6V29	8501CO7V29	8501CO8V29	8501CO15V29	8501CO16V29

**Table 23.64: Relays: DC Rated Contacts, 20 A at 110 V (sold in lots of 1)**

Coil Voltage	Number and type of contacts - Thermal current (lth)
	SPST: 1 NO / 0 NC Catalog Number
6 Vdc	8501CDO21V50
12 Vdc	8501CDO21V51
24 Vdc	8501CDO21V53
110 Vdc	8501CDO21V60
6 Vac	8501CO21V35
12 Vac	8501CO21V36
24 Vac	8501CO21V14
120 Vac	8501CO21V20
208 Vac	8501CO21V08
240 Vac	8501CO21V24
277 Vac	8501CO21V04
480 Vac	8501CO21V29

**Table 23.65: Relays: DC Rated Contacts, 10 A at 110 V (sold in lots of 1)**

Coil Voltage	Number and type of contacts - Thermal current (lth)
	DPDT: 1 NO / 0 NC Catalog Number
6 Vdc	8501CDO22V50
12 Vdc	8501CDO22V51
24 Vdc	8501CDO22V53
110 Vdc	8501CDO22V60
6 Vac	8501CO22V35
12 Vac	8501CO22V36
24 Vac	8501CO22V14
120 Vac	8501CO22V20
208 Vac	8501CO21V08
240 Vac	8501CO22V24
277 Vac	8501CO22V04
480 Vac	8501CO22V29

**Approvals for Square D Power Relays**



File: E78351  
CCN: NLDX,  
NLDX7



File: 218139  
Class: 3211 04



IEC 60947-4-1



UL Listed when used with corresponding sockets



750H Hazardous Location Relay

750H Hazardous Location Series  
DPDT, PDT 12A

Contact Rating	Contact Configuration	Nominal Voltage	Coil Resistance (Ω)	Standard Part Number
12 A	DPDT	12 Vac, 50/60 Hz	18	750XBXH12A
		24 Vac, 50/60 Hz	72	750XBXH24A
		120 Vac, 50/60 Hz	1700	750XBXH120A
		240 Vac, 50/60 Hz	7200	750XBXH240A
		12 Vdc	120	750XBXH12D
		24 Vdc	470	750XBXH24D
	110 Vdc	10000	750XBXH110D	
	3PDT	12 Vac, 50/60 Hz	18	750CXH12A
		24 Vac, 50/60 Hz	72	750CXH24A
		120 Vac, 50/60 Hz	1700	750CXH120A
		240 Vac, 50/60 Hz	7200	750CXH240A
		12 Vdc	120	750CXH12D
24 Vdc		470	750CXH24D	
		110 Vdc	10,000	750CXH110D

750H Specifications

Part Number	750XBXH	750CXH
<b>Contact Characteristics</b>		
Terminal Style	Octal	
Contact Material	Silver Alloy	
Load Type	Standard	
Contact Configuration	DPDT	3PDT
Carrying Current	12A	
Maximum Switching Voltage	300 V	
Rated Switching Current Conforming to UL and ANSI/ ISA 12.12.01)	Resistive	12 A at 120 Vac, 50/60 Hz, 100,000 cycles 12 A at 240 Vac, 50/60 Hz, 100,000 cycles 12 A at 28 Vdc, 100,000 cycles
	Motor	1/2 hp at 240 Vac, 50/60 Hz, 100,000 cycles 1/3 hp at 120 Vac, 50/60 Hz, 100,000 cycles
	Pilot Duty	B300 — 100,000 cycles
Minimum Switching Requirement	100 mA at 5 Vdc	
<b>Coil Characteristics</b>		
Maximum Operating Voltage	110% (AC/DC)	
Maximum Pickup Voltage	85% (AC); 80% (DC)	
Drop-out Voltage Threshold	15% (AC); 10% (DC)	
Average Consumption	2.75 VA at 60 Hz (AC); 1.2 W (DC)	

Dimensions, in. (mm)

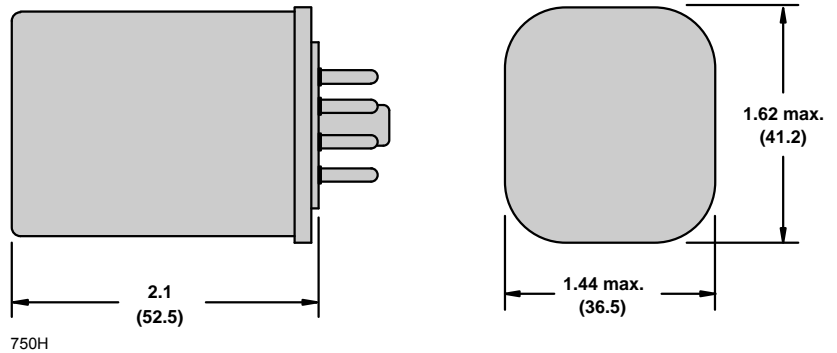

**Wiring Diagrams**

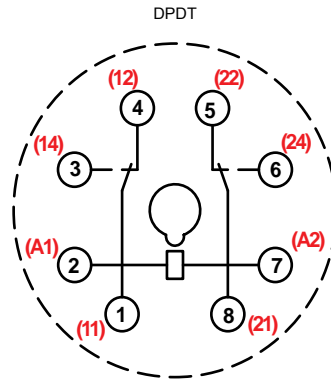

**NEMA (IEC)**

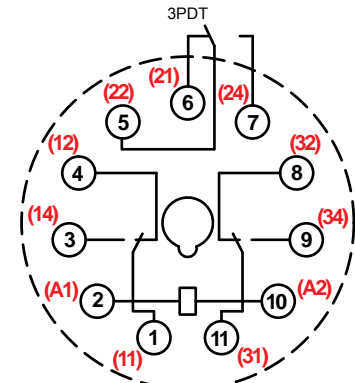

**NEMA (IEC)**

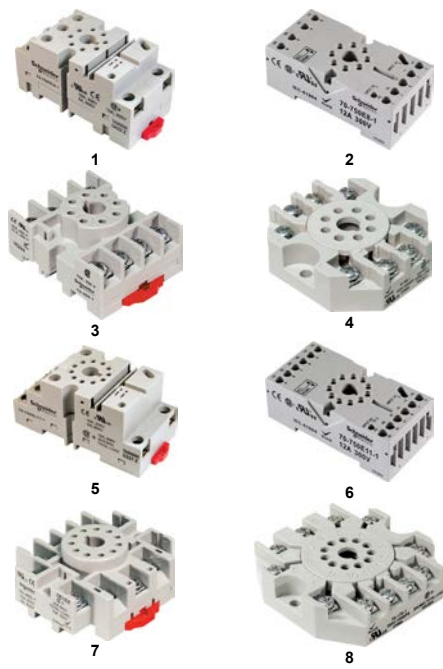

**Relay Accessories**

Description	Function	For Use with Relays	Pkg. Min.	Standard Part Number
1 Socket	DIN or panel mounting with screw terminals	750XBXH	10	70750DL81
2 Socket	DIN or panel mounting with elevator terminals, module		10	70750E81
3 Socket	DIN or panel mounting with screw terminals and clamping plates		10	704641
4 Socket	Panel mounting with screw terminals and clamping plates		10	701691
5 Socket	DIN or panel mounting	750XCXH	10	70750DL111
6 Socket	DIN or panel mounting with elevator terminals		10	70750E111
7 Socket	DIN or panel mounting with screw terminals and clamping plates		10	704651
8 Socket	Panel mounting with screw terminals and clamping plates		10	701701



**CLASS I DIVISION 2**  
Class I, Division 2 certification for use in hazardous locations. (Temperature code: T5)



861H Relay

**861H Solid-State Relays**  
861H—SPST-NO, 8–15 A

Switching Type	Switching Device (1)	Input Voltage Range	Output Voltage Range	Contact Configuration	Rated Output Current (A)	Standard Part Number	
DC Switching	MOSFET	3.5–32 Vdc	3–50 Vdc	SPST-NO	15	861HSSR115DD	
			3–150 Vdc	SPST-NO	8	861HSSR208DD	
AC Random	Triac	3–32 Vdc	24–280 Vac	SPST-NO	8	861HSSRA208DC2	
				SPST-NC	8	861HSSRA208DC4	
			48–480 Vac	SPST-NO	8	861HSSRA408DC2	
				SPST-NO	8	861HSSRA208AC2	
			90–280 Vac	48–480 Vac	SPST-NO	8	861HSSRA408AC2
				48–480 Vac	SPST-NO	8	861HSSRA210DC2
	SCR	3–32 Vdc	24–280 Vac	SPST-NO	10	861HSSR210DC4	
				SPST-NO	10	861HSSR410DC2	
		48–480 Vac	SPST-NO	10	861HSSR610DC2		
			SPST-NO	10	861HSSR210AC2		
		90–280 Vac	24–280 Vac	SPST-NO	10	861HSSR410AC2	
			48–600 Vac	SPST-NO	10	861HSSR610AC2	
AC Zero Cross	Triac	3–32 Vdc	24–280 Vac	SPST-NO	8	861HSSRA208DC1	
				SPST-NO	8	861HSSRA408DC1	
			48–480 Vac	SPST-NO	8	861HSSR210AC1	
				SPST-NO	8	861HSSRA408AC1	
			90–280 Vac	24–280 Vac	SPST-NO	8	861HSSR210DC1
				48–480 Vac	SPST-NO	8	861HSSR410DC1
	SCR	3–32 Vdc	24–280 Vac	SPST-NO	10	861HSSR210DC1	
				SPST-NO	10	861HSSR410DC1	
		48–480 Vac	SPST-NO	10	861HSSR610DC1		
			SPST-NO	10	861HSSR210AC1		
		90–280 Vac	24–280 Vac	SPST-NO	10	861HSSR410AC1	
			48–600 Vac	SPST-NO	10	861HSSR610AC1	

**861H Specifications**

Part Number	861HSSR→DD	861HSSRA→DC*	861HSSR→DC*	861HSSRA→AC*	861HSSR→AC*
<b>Input Characteristics</b>					
Input Voltage Range	3.5–32 Vdc	3–32 Vdc		90–280 Vac	
Must Release Voltage	1 Vdc			10 Vac	
Nominal Input Impedance	Current regulator			16–25 kW	
Typical Input Current at 5 Vdc	12 mA	16 mA (12 mA for 861HSSR210-DC-4)		12 mA	
Reverse Polarity Protection	Yes			N/A	
<b>Output Characteristics</b>					
Switching Device	MOSFET	Triac	SCR	Triac	SCR
Switching Type	DC Switching	AC Zero Cross; AC Random			
Contact Configuration	SPST-NO		SPST-NO, SPST-NC		
Output Voltage Range	3–50 Vdc; 3–150 Vdc		24–480 Vac; 48–480 Vac; 48–600 Vac		
Maximum Rate of Rise Off-State Voltage (dv/dt)	N/A	250 V/us	500 V/us, 350 V/us (861HSSR410, 861HSSR610-DC-1), 200 V/us (861HSSR210-DC-4, 861HSSR610-DC-2)	250 V/us	500 V/us, 350 V/us (861HSSR410), 250 V/us (861HSSR610)
Current Ratings	Load rating	8 A (rms), 15 A (rms)	8 A (rms)	10 A (rms)	8 A (rms)
	Incandescent lamp rating	N/A	5 A (rms)	8 A (rms)	5 A (rms)
	Motor load rating	N/A	3 A (rms)	4.5 A (rms)	3 A (rms)
Minimum Load Current—Maintain On	20 mA	150 mA	50 mA	150 mA	50 mA
Non-Repetitive Surge Current (1 cycle)	861HSSR115-DD: 35 A; 861HSSR208-DD: 50 A	200 A	500 A	200 A	500 A
Maximum RMS Overload Current (1 s)	861HSSR115-DD: 17 A; 861HSSR208-DD: 24 A	24 A			
Maximum Off-State Leakage Current	0.25 mA	10 mA (rms)			
Typical On-State Voltage Drop	N/A	1.25 Vac (rms)			
Maximum On-State Voltage Drop	0.5 Vdc	1.6 Vac (rms)			
Maximum On-State Resistance	40 mW	N/A			
Maximum Turn-On Time	5 ms	8.3 ms			
Maximum Turn-Off Time	5 ms	8.3 ms			
Maximum I <sup>2</sup> T for Fusing	N/A	250 A <sup>2</sup> sec	1250 A <sup>2</sup> sec (861HSSR210); 850 A <sup>2</sup> sec (861HSSR410); 600 A <sup>2</sup> sec (861HSSR610)	250 A <sup>2</sup> sec	1250 A <sup>2</sup> sec (861HSSR210); 850 A <sup>2</sup> sec (861HSSR410); 600 A <sup>2</sup> sec (861HSSR610)

Dimensions, in. (mm)

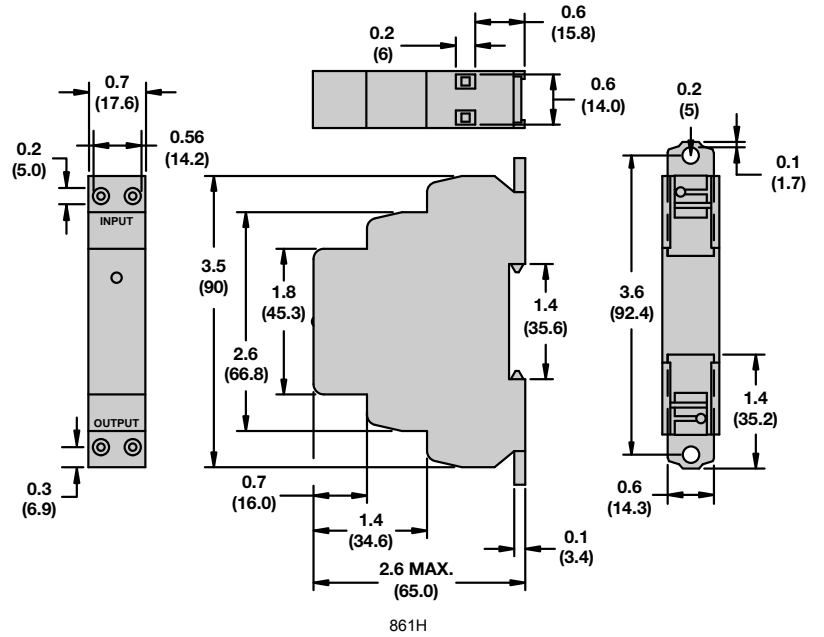

Wiring Diagram

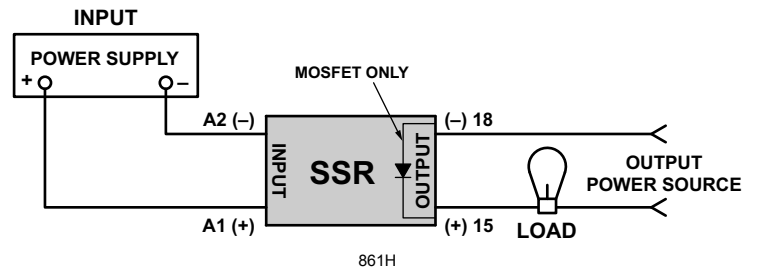



SSL1A12JD



SSLVA1



RSLZ2



RSLZ3

**Zelio™ SSL Relays**

Zelio SSL solid state relays offer the advantages of several input and output configurations for both AC and DC switching applications. Their compact size and modular design reduces space and allows easy mounting on the socket. Key features include:

- Available with zero voltage switching for resistive load and random switching for inductive load applications.
- Socket with reverse polarity protection circuit and LED indicator for easy identification of control status.

Refer to [Online EZ Selector](#).

**Table 23.66: Relays (sold in lots of 12)**

Switching	Input Voltage	Output Voltage	Contact Configuration	Load Current Range	SPDT (1 C/O) Catalog Number
DC switching	3–12 Vdc	1–24 Vdc	SPST N.O. (1 N/O)	3.5 A	SSL1D03JD
		1–48 Vdc	SPST N.O. (1 N/O)	0.1 A	SSL1D101JD
	15–30 Vdc	1–24 Vdc	SPST N.O. (1 N/O)	3.5 A	SSL1D03BD
		1–48 Vdc	SPST N.O. (1 N/O)	0.1 A	SSL1D101BD
	38–72 Vdc	1–24 Vdc	SPST N.O. (1 N/O)	3.5 A	SSL1D03ND
		1–48 Vdc	SPST N.O. (1 N/O)	0.1 A	SSL1D101ND
Zero voltage switching	3–12 Vdc	24–280 Vac	SPST N.O. (1 N/O)	2 A	SSL1A12JD
	15–30 Vdc	24–280 Vac	SPST N.O. (1 N/O)	2 A	SSL1A12BD
	38–72 Vdc	24–280 Vac	SPST N.O. (1 N/O)	2 A	SSL1A12ND
Random switching	3–12 Vdc	24–280 Vac	SPST N.O. (1 N/O)	2 A	SSL1A12JDR
	15–30 Vdc	24–280 Vac	SPST N.O. (1 N/O)	2 A	SSL1A12BDR
	38–72 Vdc	24–280 Vac	SPST N.O. (1 N/O)	2 A	SSL1A12NDR

**Table 23.67: Sockets (sold in lots of 10)**

Control Voltage	For Use with Relays	Socket Type	
		Screw Connector Catalog Number	Spring Terminal Catalog Number
5 Vdc	SSL1D03JD SSL1D101JD SSL1A12JD SSL1A12JDR	SSLZVA1	SSLZRA1
24 Vdc	SSL1D03BD SSL1D101BD SSL1A12BD SSL1A12BDR	SSLZVA1	SSLZRA1
60 Vdc	SSL1D03ND SSL1D101ND SSL1A12ND SSL1A12NDR	SSLZVA2	SSLZRA2
110 Vac/Vdc	SSL1D03ND SSL1D101ND SSL1A12ND SSL1A12NDR	SSLZVA3	SSLZRA3
230 Vac/Vdc	SSL1D03ND SSL1D101ND SSL1A12ND SSL1A12NDR	SSLZVA4	SSLZRA4

**Table 23.68: Accessories**

Description	Compatibility	Catalog Number
ID tags (2 sheets of 64 tags)		RSLZ5
Bus jumper (10 x 20-pole jumper)	RSL series sockets, SSL series sockets	RSLZ2
Butterfly isolator (10 isolators)		RSLZ3

**Approvals for SSL Relays**



File:  
E173076  
CCN:  
NRNT2,  
NRNT8



File:  
257594  
Class:  
3211 07



IEC 60950–1 RoHS Compliant

**Approvals for SSLZ Sockets**



File:  
E172326  
CCN:  
SWIV2



File:  
254977  
Class:  
3211 07



IEC 60950–1 RoHS Compliant

### Zelio™ SSM Relays

Zelio SSM solid state relays are ready-to-use modular relays with SCR/MOSFET outputs for greater switching density. The unique IP20 housing design and integrated heat sink with no exposed metal surface offers compactness and enhances operating conditions of the relay. SSM relays are DIN rail mounted and available with zero voltage switching for resistive load and random switching for inductive load applications. The SSM relay range comprises:

- SSM1: Single channel, single-phase relays with 6 A and 12 A ratings
- SSM2: Dual channel, single-phase relays with 6 A rating

Refer to [Online EZ Selector](#).



SSM1A36BD



SSM1A312BD

**Table 23.69: SSM1 Single Channel Solid State Relays (sold in lots of 1)**

Switching	Input Voltage	Output Voltage	Contact Configuration	Load Current Range	Motor Load Rating	Catalog Number
DC switching	4–32 Vdc	1–60 Vdc	SPST N.O. (1 N/O)	6 A	–	SSM1D26BD
			SPST N.O. (1 N/O)	12 A	–	SSM1D212BD
		1–100 Vdc	SPST N.O. (1 N/O)	6 A	–	SSM1D36BD
			SPST N.O. (1 N/O)	12 A	–	SSM1D312BD
Zero voltage switching	4–32 Vdc	24–280 Vac	SPST N.O. (1 N/O)	6 A	1/6 hp @ 240 Vac	SSM1A16BD
			SPST N.O. (1 N/O)	12 A	1/3 hp @ 240 Vac	SSM1A112BD
		48–600 Vac	SPST N.O. (1 N/O)	6 A	1/6 hp @ 240 Vac	SSM1A36BD
			SPST N.O. (1 N/O)	12 A	1/3 hp @ 240 Vac	SSM1A312BD
	18–36 Vac	24–280 Vdc	SPST N.O. (1 N/O)	6 A	1/6 hp @ 240 Vac	SSM1A16B7
			SPST N.O. (1 N/O)	12 A	1/3 hp @ 240 Vac	SSM1A112B7
		48–600 Vac	SPST N.O. (1 N/O)	12 A	1/3 hp @ 240 Vac	SSM1A312B7
			SPST N.O. (1 N/O)	6 A	1/6 hp @ 240 Vac	SSM1A16F7
	90–140 Vac	24–280 Vac	SPST N.O. (1 N/O)	12 A	1/3 hp @ 240 Vac	SSM1A112F7
			SPST N.O. (1 N/O)	12 A	1/3 hp @ 240 Vac	SSM1A312F7
		48–600 Vac	SPST N.O. (1 N/O)	6 A	1/6 hp @ 240 Vac	SSM1A16P7
			SPST N.O. (1 N/O)	12 A	1/3 hp @ 240 Vac	SSM1A112P7
	200–265 Vac	24–280 Vac	SPST N.O. (1 N/O)	12 A	1/3 hp @ 240 Vac	SSM1A312P7
			SPST N.O. (1 N/O)	6 A	1/6 hp @ 240 Vac	SSM1A16BDR
		48–600 Vac	SPST N.O. (1 N/O)	12 A	1/3 hp @ 240 Vac	SSM1A112BDR
			SPST N.O. (1 N/O)	6 A	1/6 hp @ 240 Vac	SSM1A36BDR
Random switching	4–32 Vdc	24–280 Vac	SPST N.O. (1 N/O)	12 A	1/3 hp @ 240 Vac	SSM1A312BDR
			SPST N.O. (1 N/O)	6 A	1/6 hp @ 240 Vac	SSM1A16B7R
		48–600 Vac	SPST N.O. (1 N/O)	12 A	1/3 hp @ 240 Vac	SSM1A112B7R
			SPST N.O. (1 N/O)	12 A	1/3 hp @ 240 Vac	SSM1A312B7R
	18–36 Vac	24–280 Vac	SPST N.O. (1 N/O)	6 A	1/6 hp @ 240 Vac	SSM1A16F7R
			SPST N.O. (1 N/O)	12 A	1/3 hp @ 240 Vac	SSM1A112F7R
		48–600 Vac	SPST N.O. (1 N/O)	12 A	1/3 hp @ 240 Vac	SSM1A312F7R
			SPST N.O. (1 N/O)	6 A	1/6 hp @ 240 Vac	SSM1A16P7R
	90–140 Vac	24–280 Vac	SPST N.O. (1 N/O)	12 A	1/3 hp @ 240 Vac	SSM1A112P7R
			SPST N.O. (1 N/O)	12 A	1/3 hp @ 240 Vac	SSM1A312P7R
		48–600 Vac	SPST N.O. (1 N/O)	6 A	1/6 hp @ 240 Vac	SSM1A16P7R
			SPST N.O. (1 N/O)	12 A	1/3 hp @ 240 Vac	SSM1A112P7R
200–265 Vac	24–280 Vac	SPST N.O. (1 N/O)	12 A	1/3 hp @ 240 Vac	SSM1A312P7R	
		SPST N.O. (1 N/O)	6 A	1/6 hp @ 240 Vac	SSM1A16P7R	
	48–600 Vac	SPST N.O. (1 N/O)	12 A	1/3 hp @ 240 Vac	SSM1A112P7R	
		SPST N.O. (1 N/O)	12 A	1/3 hp @ 240 Vac	SSM1A312P7R	



SSM2A36BD

Table 23.70: SSM2 Dual Channel Solid State Relays (sold in lots of 1)

Switching	Input Voltage	Output Voltage	Contact Configuration	Load Current Range	Catalog Number [1]
Zero voltage switching	4–32 Vdc	24–280 Vac	DPST N.O. (2 N/O)	6	SSM2A16BD
		48–600 Vac	DPST N.O. (2 N/O)	6	SSM2A36BD
Random switching	4–32 Vdc	24–280 Vac	DPST N.O. (2 N/O)	6	SSM2A16BDR
		48–600 Vac	DPST N.O. (2 N/O)	6	SSM2A36BDR

## Approvals for SSM Relays



File: E359576  
CCN: NMFT2,  
NMFT8



File: 257594  
Class: 3211 04



IEC  
60950-1

RoHS  
Compliant

[1] 4-pin connector for dual channel output only. Mating connector: MOLEX 050579404 or equivalent.

**Zelio™ SSL, SSM and SSP**

Zelio SSL, SSM and SSP relays do not have any moving parts to wear out. Combined with vibration resistance, arc-less switching and the lack of acoustical noise, solid state relays are the ideal product for switching applications that demand reliable execution. For added reliability, the Zelio SSL, SSM and SSP solid state relays use Direct Copper Bonding (DCB) technology to decrease internal temperatures and improve the overall quality of the product. The SSR solid state relay range comprises:

- Relays for DIN rail mounting: SSRD
- Relays for panel mounting: SSRP

Key features include:

- Input voltage range 3–32 Vdc, 90–280 Vac
- Breaking capacities up to 125 A
- Zero voltage turn on, low EMI/RFI
- No moving parts
- Shock and vibration resistant
- No acoustical noise
- Fast response
- Arc-less switching
- Long life (>10<sup>9</sup> operations typical)

Refer to [Online EZ Selector](#).

**Table 23.71: Pre-assembled solid state slim relays**

Relays mounted on screw sockets (sold in lots of 30)					
1 NO contact Switching	Voltage Range		Load Current Range	Reference	Weight
	Control Input	Load Output			
	V	V	A		kg/lb
DC Switching	4 to 12	1 to 24	3.5	SSL1D03JDPV (SSL1D03JD + SSLZVA1)	0.033/0.073
	4 to 12	1 to 48	0.1	SSL1D101JDPV (SSL1D101JD + SSLZVA1)	0.033/0.073
Zero voltage switching	4 to 12	24 to 250	2	SSL1A12JDPV (SSL1A12JD+SSLZVA1)	0.033/0.073
Random switching	4 to 12	24 to 250	2	SSL1A12JDRPV (SSL1A12JDR + SSLZVA1)	0.033/0.073
DC Switching	16 to 30	1 to 24	3.5	SSL1D03BDPV (SSL1D03BD+SSLZVA1)	0.033/0.073
	16 to 30	1 to 48	0.1	SSL1D101BDPV (SSL1D101BD + SSLZVA1)	0.033/0.073
Zero voltage switching	16 to 30	24 to 250	2	SSL1A12BDPV (SSL1A12BD+SSLZVA1)	0.033/0.073
Random switching	16 to 30	24 to 250	2	SSL1A12BDRPV (SSL1A12BDR + SSLZVA1)	0.033/0.073
Relays mounted on spring sockets (sold in lots of 30)					
DC Switching	4 to 12	1 to 24	3.5	SSL1D03JDPR (SSL1D03JD+SSLZRA1)	0.033/0.073
	4 to 12	1 to 48	0.1	SSL1D101JDPR (SSL1D101JD + SSLZRA1)	0.033/0.073
Zero voltage switching	4 to 12	24 to 250	2	SSL1A12JDPR (SSL1A12JD+SSLZRA1)	0.033/0.073
Random switching	4 to 12	24 to 250	2	SSL1A12JDRPR (SSL1A12JDR + SSLZRA1)	0.033/0.073
DC Switching	16 to 30	1 to 24	3.5	SSL1D03BDPR (SSL1D03BD + SSLZRA1)	0.033/0.073
	16 to 30	1 to 48	0.1	SSL1D101BDPR (SSL1D101BD + SSLZRA1)	0.033/0.073
Zero voltage switching	16 to 30	24 to 250	2	SSL1A12BDPR (SSL1A12BD + SSLZRA1)	0.033/0.073
Random switching	16 to 30	24 to 250	2	SSL1A12BDRPR (SSL1A12BDR + SSLZRA1)	0.033/0.073



SSP1D425BD



SSM1A120M7



SSM1A445BD



SSRHP07

Table 23.72: Relays and sockets for customer assembly

SSL single-phase solid state relays (sold in lots of 12)					
Switching	Voltage Range		Load Current Range	Reference	Weight
	Control Input	Load Output			
	V	V	A		kg/lb
DC Switching	3 to 12	1 to 24	3.5	SSL1D03JD	0.004/0.009
		1 to 48	0.1	SSL1D101JD	0.004/0.009
	15 to 30	1 to 24	3.5	SSL1D03BD	0.004/0.009
		1 to 48	0.1	SSL1D101BD	0.004/0.009
	38 to 72	1 to 24	3.5	SSL1D03ND	0.004/0.009
1 to 48		0.1	SSL1D101ND	0.004/0.009	
Zero voltage switching	4 to 12	24 to 250	2	SSL1A12JD	0.033/0.073
Random switching	4 to 12	24 to 250	2	SSL1A12BD	0.033/0.073
DC Switching	16 to 30	1 to 24	3.5	SSL1A12ND	0.033/0.073
	16 to 30	1 to 48	0.1	SSL1A12JDR	0.033/0.073
Zero voltage switching	16 to 30	24 to 250	2	SSL1A12BDR	0.033/0.073
		24 to 250	2	SSL1A12NDR	0.033/0.073

Sockets equipped with LED and protection circuit (sold in lots of 10)					
Control Voltage (Nominal)	For Use With Relays	Socket Type		Unit Reference	Weight kg/lb
		Screw Connector			
		Unit Reference	Weight kg/lb		
5	SSL1D03JD SSL1D101JD SSL1A12JD SSL1A12JDR	SSLZVA1	0.029/ 0.063	SSLZRA1	0.029/0.063
24	SSL1D03BD SSL1D101BD SSL1A12BD SSL1A12BDR	SSLZVA1	0.029/ 0.063	SSLZRA1	0.029/0.063
60	SSL1D03ND SSL1D101ND SSL1A12ND SSL1A12NDR	SSLZVA2	0.029/ 0.063	SSLZRA2	0.029/0.063
110	SSL1D03ND SSL1D101ND SSL1A12ND SSL1A12NDR	SSLZVA3	0.029/ 0.063	SSLZRA3	0.029/0.063
230	SSL1D03ND SSL1D101ND SSL1A12ND SSL1A12NDR	SSLZVA4	0.029/ 0.063	SSLZRA4	0.029/0.063

Table 23.73: SSM1 single-phase solid state relays (12 and 18 mm)

Description	Compatibility	Reference	Weight kg/lb
Clip-in legends (2 sheets of 64 legends)	SSL sockets	RSLZ5	0.001/0.002
Bus jumper (10 x 20-pole jumper)	SSL sockets	RSLZ2	0.001/0.002
Partition plate (10 partition plates)	SSL sockets	RSLZ3	0.001/0.002

Table 23.74: SSM1 single-phase solid state relays (12 and 18 mm)

Switching	Voltage range		Load current range	Reference	Weight kg/lb
	Control input	Load output			
	V	V	A		
DC switching	4...32	1...60	6	SSM1D26BD	0.050/0.110
			12	SSM1D212BD	0.090/0.198
		1...100	6	SSM1D36BD	0.050/0.110
			12	SSM1D312BD	0.090/0.198
Zero voltage switching	4...32	24...280	6	SSM1A16BD	0.050/0.110
			12	SSM1A112BD	0.090/0.198
		48...600	6	SSM1A36BD	0.050/0.110
			12	SSM1A312BD	0.090/0.198
	18...36	24...280	6	SSM1A16B7	0.050/0.110
			12	SSM1A112B7	0.090/0.198
		48...600	6	SSM1A36B7	0.050/0.110
			12	SSM1A312B7	0.090/0.198
	90...140	24...280	6	SSM1A16F7	0.050/0.110
			12	SSM1A112F7	0.090/0.198
		48...600	6	SSM1A36F7	0.050/0.110
			12	SSM1A312F7	0.090/0.198
200...265	24...280	6	SSM1A16P7	0.050/0.110	
		12	SSM1A112P7	0.090/0.198	
	48...600	6	SSM1A36P7	0.050/0.110	
		12	SSM1A312P7	0.090/0.198	
Random switching	4...32	24...280	6	SSM1A16BDR	0.050/0.110
			12	SSM1A112BDR	0.090/0.198
		48...600	6	SSM1A36BDR	0.050/0.110
			12	SSM1A312BDR	0.090/0.198
	18...36	24...280	6	SSM1A16B7R	0.050/0.110
			12	SSM1A112B7R	0.090/0.198
		48...600	6	SSM1A36B7R	0.050/0.110
			12	SSM1A312B7R	0.090/0.198
	90...140	24...280	6	SSM1A16F7R	0.050/0.110
			12	SSM1A112F7R	0.090/0.198
		48...600	6	SSM1A36F7R	0.050/0.110
			12	SSM1A312F7R	0.090/0.198
	200...265	24...280	6	SSM1A16P7R	0.050/0.110
			12	SSM1A112P7R	0.090/0.198
		48...600	6	SSM1A36P7R	0.050/0.110
			12	SSM1A312P7R	0.090/0.198

**Table 23.75: SSM2 single-phase solid state relays, dual channel**

Switching	Voltage range		Load current range	Reference	Weight kg/lb
	Control input	Load output			
	V	V			
Zero voltage switching	4...32	24...280	6	SSM2A16BD	0.090/0.198
		48...6000	6	SSM2A36BD	0.090/0.198
Random switching	4...32	24...280	6	SSM2A16BDR	0.090/0.198
		48...6000	6	SSM2A36BDR	0.090/0.198

**Table 23.76: SSM1 single-phase solid state relays (22.5 and 45 mm)**

Switching	Voltage range		Load current range	Reference	Weight kg/lb
	Control input	Load output			
	V	V			
Zero voltage switching	4...32	24...280	20	SSM1A120BD	0.280/0.617
			30	SSM1A130BD	0.280/0.617
	3...32	24...280	45	SSM1A145BD	0.476/1.049
			30	SSM1A430BD	0.280/0.617
	4...32	48...660	45	SSM1A445BD	0.476/1.049
			55	SSM1A455BD	0.476/1.049
			20	SSM1A120M7	0.280/0.617
	90...280	24...280	30	SSM1A130M7	0.280/0.617
			30	SSM1A430M7	0.280/0.617
			45	SSM1A145F7	0.476/1.049
	90...140	48...660	45	SSM1A445F7	0.476/1.049
			55	SSM1A455F7	0.476/1.049

**Table 23.77: SSM3 three-phase solid state relays**

Switching	Voltage range		Load current range	Reference	Weight kg/lb
	Control input	Load output			
	V	V			
Zero voltage switching	4...32	48...600	25	SSM3A325BD	0.740/1.631
		90...140	25	SSM3A325F7	0.740/1.631
		180...280	25	SSM3A325P7	0.740/1.631
		4...32	48...600	25	SSM3A325BDR

**Table 23.78: SSP1 single-phase solid state relays**

Switching	Voltage range		Load current range	Reference	Weight kg/lb
	Control input	Load output			
	V	V			
<b>Relays with embedded thermal pad</b>					
DC switching	3.5...32	1...150	12	SSP1D412BDT	0.089/0.196
			25	SSP1D425BDT	0.089/0.196
			40	SSP1D440BDT	0.089/0.196
Zero voltage switching	3...32	24...300	10	SSP1A110BDT	0.089/0.196
			25	SSP1A125BDT	0.089/0.196
			50	SSP1A150BDT	0.089/0.196
			75	SSP1A175BDT	0.089/0.196
			50	SSP1A450BDT	0.089/0.196
			75	SSP1A475BDT	0.089/0.196
	4...32	48...660	90	SSP1A490BDT	0.089/0.196
			125	SSP1A4125BDT	0.089/0.196
			10	SSP1A110M7T	0.089/0.196
			25	SSP1A125M7T	0.089/0.196
			50	SSP1A150M7T	0.089/0.196
			75	SSP1A175M7T	0.089/0.196
			50	SSP1A450M7T	0.089/0.196
			75	SSP1A475M7T	0.089/0.196
90...280	24...300	90	SSP1A490M7T	0.089/0.196	
		125	SSP1A4125M7T	0.089/0.196	
		10	SSP1A110M7	0.089/0.196	
		25	SSP1A125M7	0.089/0.196	
		50	SSP1A150M7	0.089/0.196	
		75	SSP1A175M7	0.089/0.196	
48...660	48...660	50	SSP1A450M7	0.089/0.196	
		75	SSP1A475M7	0.089/0.196	
		90	SSP1A490M7	0.089/0.196	
		125	SSP1A4125M7	0.089/0.196	
		10	SSP1A110M7	0.089/0.196	
		25	SSP1A125M7	0.089/0.196	
		50	SSP1A150M7	0.089/0.196	
		75	SSP1A175M7	0.089/0.196	
<b>Relays without embedded thermal pad</b>					
DC switching	3.5...32	1...150	12	SSP1D412BD	0.089/0.196
			25	SSP1D425BD	0.089/0.196
			40	SSP1D440BD	0.089/0.196
Zero voltage switching	3...32	24...300	10	SSP1A110BD	0.089/0.196
			20	SSP1A125BD	0.089/0.196
			50	SSP1A150BD	0.089/0.196
			75	SSP1A175BD	0.089/0.196
			50	SSP1A450BD	0.089/0.196
			75	SSP1A475BD	0.089/0.196
	4...32	48...660	90	SSP1A490BD	0.089/0.196
			125	SSP1A4125BD	0.089/0.196
			10	SSP1A110M7	0.089/0.196
			25	SSP1A125M7	0.089/0.196
			50	SSP1A150M7	0.089/0.196
			75	SSP1A175M7	0.089/0.196
			50	SSP1A450M7	0.089/0.196
			75	SSP1A475M7	0.089/0.196
90...280	24...300	90	SSP1A490M7	0.089/0.196	
		125	SSP1A4125M7	0.089/0.196	
		10	SSP1A110M7	0.089/0.196	
		25	SSP1A125M7	0.089/0.196	
		50	SSP1A150M7	0.089/0.196	
		75	SSP1A175M7	0.089/0.196	
48...660	48...660	50	SSP1A450M7	0.089/0.196	
		75	SSP1A475M7	0.089/0.196	
		90	SSP1A490M7	0.089/0.196	
		125	SSP1A4125M7	0.089/0.196	
		10	SSP1A110M7	0.089/0.196	
		25	SSP1A125M7	0.089/0.196	
		50	SSP1A150M7	0.089/0.196	
		75	SSP1A175M7	0.089/0.196	
<b>Relays with embedded thermal pad and smart diagnostic features</b>					
Zero voltage switching	3...32	24...300	25	SSP1A125BDS	0.097/0.214
			50	SSP1A150BDS	0.097/0.214
			50	SSP1A450BDS	0.097/0.214
	4...32	48...660	75	SSP1A475BDS	0.097/0.214
			90	SSP1A490BDS	0.097/0.214
			125	SSP1A4125BDS	0.097/0.214

Table 23.79: SSP3 three-phase solid state relays

Switching	Voltage range		Load current range	Reference	Weight kg/lb
	Control input	Load output			
	V	V			
<b>Relays with embedded thermal pad</b>					
Zero voltage switching	4...32	48...530	25	SSP3A225BDT	0.240/0.529
			50	SSP3A250BDT	0.240/0.529
	18...36	48...530	25	SSP3A225B7T	0.240/0.529
			50	SSP3A250B7T	0.240/0.529
	90...140	48...530	25	SSP3A225F7T	0.240/0.529
			50	SSP3A250F7T	0.240/0.529
	180...280	48...530	25	SSP3A225P7T	0.240/0.529
			50	SSP3A250P7T	0.240/0.529
Random switching	4...32	48...530	25	SSP3A225BDRT	0.240/0.529
			50	SSP3A250BDRT	0.240/0.529
	18...36	48...530	25	SSP3A225B7RT	0.240/0.529
			50	SSP3A250B7RT	0.240/0.529
	90...140	48...530	25	SSP3A225F7RT	0.240/0.529
			50	SSP3A250F7RT	0.240/0.529
	180...280	48...530	25	SSP3A225P7RT	0.240/0.529
			50	SSP3A250P7RT	0.240/0.529
<b>Relays without embedded thermal pad</b>					
Zero voltage switching	4...32	48...530	25	SSP3A225BD	0.240/0.529
			50	SSP3A250BD	0.240/0.529
	18...36	48...530	25	SSP3A225B7	0.240/0.529
			50	SSP3A250B7	0.240/0.529
	90...140	48...530	25	SSP3A225F7	0.240/0.529
			50	SSP3A250F7	0.240/0.529
	180...280	48...530	25	SSP3A225P7	0.240/0.529
			50	SSP3A250P7	0.240/0.529
Random switching	4...32	48...530	25	SSP3A225BDR	0.240/0.529
			50	SSP3A250BDR	0.240/0.529
	18...36	48...530	25	SSP3A225B7R	0.240/0.529
			50	SSP3A250B7R	0.240/0.529
	90...140	48...530	25	SSP3A225F7R	0.240/0.529
			50	SSP3A250F7R	0.240/0.529
	180...280	48...530	25	SSP3A225P7R	0.240/0.529
			50	SSP3A250P7R	0.240/0.529

Table 23.80: Heat sinks for customer assembly

Mounting	Number and type of relays supported	Surface area	Thermal resistance	Reference	Weight kg/lb
		cm <sup>2</sup> /in <sup>2</sup>	oC/W		
Panel mount	Up to 3 SSP1 units 1 SSP3 unit	6,823/1,058	0.2	SSRHP02	2.592/5.714
	Up to 3 SSP1 units 1 SSP3 unit	4,406/683	0.5	SSRHP05	1.440/3.174
	1 SSP1 unit	1,640/254	0.7	SSRHP07	0.526/1.159
	Up to 3 SSP1 units 1 SSP3 unit	1,425/221	1	SSRHP10	0.620/1.367
	Up to 2 SSP1 units	659/102	1.7	SSRHP17	0.195/0.430
	1 SSP1 unit	336/52.10	2.5	SSRHP25	0.100/0.220
DIN rail mount	Up to 3 SSP1 units 1 SSP3 unit	1,425/221	1	SSRHD10	0.630/1.389

Table 23.81: Accessories

Description	Type of relays supported	Unit reference	Weight kg/lb
Copper terminal lug for AWG 6 (13.3 mm <sup>2</sup> ) to AWG 0 (53.5 mm <sup>2</sup> ) Sold in lots of 10	SSP1	SSRAL1	0.042/0.093
Copper terminal lug for AWG 14 (2.1 mm <sup>2</sup> ) to AWG 6 (13.3 mm <sup>2</sup> ) Sold in lots of 10	SSP1	SSRAL2	0.009/0.002

Approvals for SSRP and SSRD Relays



File: E258297  
CCN: NRNT2,  
NRNT8



File: 230765  
Class: 3211 07



RoHS  
Compliant



SSP3A225P7

**Zelio™ SSP Relays**

Zelio SSP solid state relays are three-phase panel mounted relays with IP20 housing. The SCR outputs allow them to be used in various power switching applications. These power relays with 25 A and 50 A current rating are EMC compliant. SSP relays are integrated with an R-C snubber circuit and TVS (Transient Voltage Suppression). They are available with zero voltage switching for resistive load and random switching for inductive load applications.

Refer to [Online EZ Selector](#).

**Table 23.82: SSP Three-Phase Solid State Relays (sold in lots of 1)**

Switching	Input Voltage	Output Voltage	Contact Configuration	Load Current Range	Motor Load Rating	Catalog Number [2]
Zero voltage switching	4–32 Vdc	48–530 Vac	3PST N.O. (3 N/O)	25 A	3/4 hp @ 120 Vac 1 hp @ 240 Vac 3 hp @ 480 Vac 4.4 hp @ 530 Vac	SSP3A225BD
				50 A	1.5 hp @ 120 Vac 3 hp @ 240 Vac 7.5 hp @ 480 Vac 8.8 hp @ 530 Vac	SSP3A250BD
	18–36 Vac	48–530 Vac	3PST N.O. (3 N/O)	25 A	3/4 hp @ 120 Vac 1 hp @ 240 Vac 3 hp @ 480 Vac 4.4 hp @ 530 Vac	SSP3A225B7
				50 A	1.5 hp @ 120 Vac 3 hp @ 240 Vac 7.5 hp @ 480 Vac 8.8 hp @ 530 Vac	SSP3A250B7
	90–140 Vac	48–530 Vac	3PST N.O. (3 N/O)	25 A	3/4 hp @ 120 Vac 1 hp @ 240 Vac 3 hp @ 480 Vac 4.4 hp @ 530 Vac	SSP3A225F7
				50 A	1.5 hp @ 120 Vac 3 hp @ 240 Vac 7.5 hp @ 480 Vac 8.8 hp @ 530 Vac	SSP3A250F7
	180–280 Vac	48–530 Vac	3PST N.O. (3 N/O)	25 A	3/4 hp @ 120 Vac 1 hp @ 240 Vac 3 hp @ 480 Vac 4.4 hp @ 530 Vac	SSP3A225P7
				50 A	1.5 hp @ 120 Vac 3 hp @ 240 Vac 7.5 hp @ 480 Vac 8.8 hp @ 530 Vac	SSP3A250P7
Random switching	4–32 Vdc	48–530 Vac	3PST N.O. (3 N/O)	25 A	3/4 hp @ 120 Vac 1 hp @ 240 Vac 3 hp @ 480 Vac 4.4 hp @ 530 Vac	SSP3A225BDR
				50 A	1.5 hp @ 120 Vac 3 hp @ 240 Vac 7.5 hp @ 480 Vac 8.8 hp @ 530 Vac	SSP3A250BDR
	18–36 Vac	48–530 Vac	3PST N.O. (3 N/O)	25 A	3/4 hp @ 120 Vac 1 hp @ 240 Vac 3 hp @ 480 Vac 4.4 hp @ 530 Vac	SSP3A225B7R
				50 A	1.5 hp @ 120 Vac 3 hp @ 240 Vac 7.5 hp @ 480 Vac 8.8 hp @ 530 Vac	SSP3A250B7R
	90–140 Vac	48–530 Vac	3PST N.O. (3 N/O)	25 A	3/4 hp @ 120 Vac 1 hp @ 240 Vac 3 hp @ 480 Vac 4.4 hp @ 530 Vac	SSP3A225F7R
				50 A	1.5 hp @ 120 Vac 3 hp @ 240 Vac 7.5 hp @ 480 Vac 8.8 hp @ 530 Vac	SSP3A250F7R
	180–280 Vac	48–530 Vac	3PST N.O. (3 N/O)	25 A	3/4 hp @ 120 Vac 1 hp @ 240 Vac 3 hp @ 480 Vac 4.4 hp @ 530 Vac	SSP3A225P7R
				50 A	1.5 hp @ 120 Vac 3 hp @ 240 Vac 7.5 hp @ 480 Vac 8.8 hp @ 530 Vac	SSP3A250P7R

[2] Add a T to the end of the part number to order the SSP with a thermal pad interface.

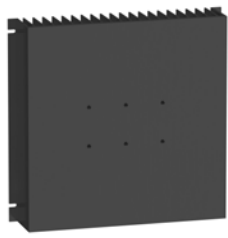

SSRHP02



SSRHP05

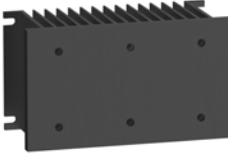

SSRHP10



SSRAT1

Table 23.83: Accessories

Description	Compatibility	Thermal Resistance	Catalog Number
Heat sink panel mount (lot of 10)	1 x SSP 1 x SSRP 2 x SSRP 3 x SSRP	0.2 °C/W	SSRHP02
	1 x SSP 1 x SSRP 2 x SSRP 3 x SSRP	0.5 °C/W	SSRHP05
	1 x SSP 1 x SSRP 2 x SSRP	1 °C/W	SSRHP10
	1 x SSRP 2 x SSRP	1.7 °C/W	SSRHP17
	1 x SSRP	2.5 °C/W	SSRHP25
Heat sink DIN rail mount (lot of 1)	1 x SSRP 2 x SSRP	0.9 °C/W	SSRAH1
	1 x SSP 1 x SSRP 2 x SSRP	1 °C/W	SSRHD10
Thermal pad interface (lot of 10)	SSRPP8S**** SSRPCDS**** SSRPCDM****	—	SSRAT1

Approvals for SSP Relays



File: E359576  
CCN: NMFT2,  
NMFT8



File: 257594  
Class: 3211 04



RoHS  
Compliant



6000 Series Relays

**6000 Solid-State Relays**  
6000—SPST-NO, 10–75 A DPST-NO, 10–25 A

Switching Type	Switching Device	Input Voltage Range	Output Voltage Range	Contact Configuration	Rated Output Current (A)	Standard Part Number		
DC Switching	MOSFET	3.5–32 Vdc	3–200 Vdc	SPST-NO	12	6312AXXMDSDC3		
					25	6325AXXMDSDC3		
					40	6340AXXMDSDC3		
AC Zero Cross	SCR	3–32 Vdc	24–280 Vac	SPST-NO	10	6210AXXSZSDC3		
					25	6225AXXSZSDC3		
					40	6240AXXSZSDC3		
					50	6250AXXSZSDC3		
					75	6275AXXSZSDC3		
					25	6425AXXSZSDC3		
		40	6440AXXSZSDC3					
		50	6450AXXSZSDC3					
		75	6475AXXSZSDC3					
		90–280 Vac	24–280 Vac	SPST-NO	10	6210AXXSZSAC90		
					25	6225AXXSZSAC90		
					40	6240AXXSZSAC90		
	50				6250AXXSZSAC90			
	75				6275AXXSZSAC90			
	25				6425AXXSZSAC90			
	48–480 Vac	48–480 Vac	SPST-NO	10	6410AXXSZSAC90			
				25	6425AXXSZSAC90			
				40	6440AXXSZSAC90			
				50	6450AXXSZSAC90			
				75	6475AXXSZSAC90			
				25	6425AXXSZBDC3			
	TRIAC <sup>[3]</sup>	3–32 Vdc	24–280 Vac	DPST-NO	10	6210BXXTZBDC3		
					48–480 Vac	DPST-NO	25	6425AXXTZBDC3
							25	6425BXXTZBDC3

**6000 Specifications (UL 508)**

Part Number	64-AXXSZSAC90	64-AXXSZSAC90	62-AXXSZSDC3	64-AXXSZSDC3
<b>Input Characteristics</b>				
Control Voltage Range	90–280 Vac (rms)		3–32 Vdc	4–32 Vdc
Maximum Turn-On Voltage	90 Vac (rms)		3 Vdc	4 Vdc
Minimum Turn-Off Voltage	10 Vac (rms)		1 Vdc	
Nominal Input Impedance	60 kΩ		N/A (active current limiter)	
Typical Input Current	2 mA at 120 V (rms); 4 mA at 240 V (rms)		10 mA at 12 Vdc	15 mA DC
<b>Output Characteristics</b>				
Switching Device	SCR			
Switching Type	AC Zero Cross			
Contact Configuration	SPST-NO			
Output Current Range	10–75 A	10–25 A	10–50 A	25–50 A
Output Voltage Range (47–63 Hz)	24–280 Vac (rms)	48–530 Vac (rms)	24–280 Vac (rms)	48–530 Vac (rms)
Transient Overvoltage	600 Vpk	1200 Vpk	600 Vpk	1200 Vpk
Maximum Off-State Leakage Current at Rated Voltage	10 mA (rms)		1 mA (rms)	
Minimum Off-State dv/dt at Maximum Rated Voltage	500 V/us			
Minimum Load Current	40 mA (rms)		150 mA (rms)	
Maximum Surge Current (16.6 ms)	10 A: 120 Apk 25 A: 250 Apk 40/50 A: 625 Apk 75 A: 1000 Apk	10 A: 140 Apk 25 A: 250 Apk	10 A: 120 Apk 25 A: 250 Apk 40/50 A: 625 Apk	25 A: 250 Apk 50 A: 625 Apk
Maximum On-State Voltage Drop at Rated Current	1.6 V (rms)	1.7 V (rms)	1.6 V (rms)	
Maximum I <sup>2</sup> T for Fusing (8.3 ms)	10 A: 60 A <sup>2</sup> sec 25 A: 260 A <sup>2</sup> sec 40/50 A: 1620 A <sup>2</sup> sec 75 A: 4150 A <sup>2</sup> sec	10 A: 81 A <sup>2</sup> sec 25 A: 260 A <sup>2</sup> sec	10 A: 60 A <sup>2</sup> sec 25 A: 260 A <sup>2</sup> sec 40/50 A: 1620 A <sup>2</sup> sec	25 A: 260 A <sup>2</sup> sec 50 A: 1620 A <sup>2</sup> sec

[3] Blade terminals.

6000 Specifications (UL 508) Continued

Part Number	50-AX125-DC3	50-AX125-DC3
<b>Input Characteristics</b>		
Control Voltage Range	3–32 Vdc	3.5–32 Vdc
Maximum Turn-On Voltage	3 Vdc	3.5 Vdc
Minimum Turn-Off Voltage	1 Vdc	
Nominal Input Impedance	Active current limiter	1 kΩ
Typical Input Current	25 A: 16 mA 10 A: 2 mA	10 mA
<b>Output Characteristics</b>		
Switching Device	TRIAC	MOSFET
Switching Type	AC Zero Cross	DC Switching
Contact Configuration	SPST-NO, DPST-NO	SPST-NO
Output Current Range	10–25 A	12–40 A
Output Voltage Range	10 A: 24–280 Vac 25 A: 48–480 Vac	3–200 Vdc
Transient Overvoltage	600 Vpk	200 Vpk
Maximum Off-State Leakage Current at Rated Voltage	10 mA	< 1 mA
Minimum Off-State dv/dt at Maximum Rated Voltage	250 V/us	N/A
Minimum Load Current—Maintain	80 mA	N/A
Maximum Surge Current (16.6 ms)	250 A	12 A: 27 A 25 A: 50 A 40 A: 90 A
Maximum On-State Voltage Drop at Rated Current	1.6 Vac (rms)	2.8 Vdc (at 40 A load)
Maximum I <sup>2</sup> T for Fusing (8.3 ms)	200 A <sup>2</sup> s	N/A
Minimum Power Factor (with Maximum Load)	0.5	0.95

Dimensions, in. (mm)

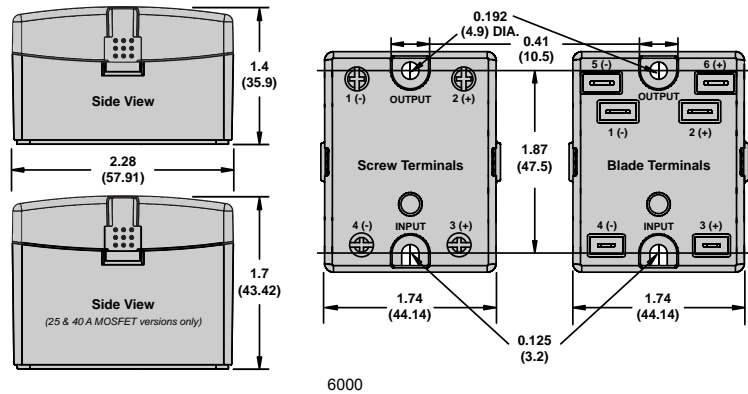

Wiring Diagram

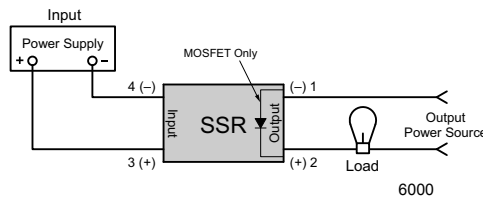

Terminal	Min.	Max.
Input	3.5 (0.138)	5 (0.197)
Output	4.2 (0.163)	6.35 (0.25)

OUTPUT	0-50 A	50-125 A
Cu 75 °C max. ambient 25 °C		

10 max  
0.393  
mm  
in

**SSRDIN Solid-State Relays**  
SSRDIN—SPST-NO, 10–45 A



SSRDIN Relay

Switching Type	Switching Device	Input Voltage Range	Output Voltage Range	Contact Configuration	Rated Output Current (A)	Standard Part Number
DC Switching	MOSFET	4–32 Vdc	0–60 Vdc	SPST-NO	10	SSR310DINDC22
					20	SSR320DINDC22
					30	SSR330DINDC22
AC Zero Cross	SCR	4–32 Vdc	24–280 Vac	SPST-NO	10	SSR210DINDC22
					20	SSR220DINDC22
					30	SSR230DINDC22
		3–32 Vdc	24–280 Vac	SPST-NO	45	SSR245DINDC45
					10	SSR610DINDC22
					20	SSR620DINDC22
		4–32 Vdc	48–660 Vac	SPST-NO	30	SSR630DINDC22
					45	SSR645DINDC45
					65	SSR665DINAC45
		90–280 Vac	24–280 Vac	SPST-NO	10	SSR210DINAC22
					20	SSR220DINAC22
					30	SSR230DINAC22
		90–140 Vac	24–280 Vac	SPST-NO	45	SSR245DINAC45
					10	SSR610DINAC22
					20	SSR620DINAC22
90–280 Vac	48–660 Vac	SPST-NO	30	SSR630DINAC22		
			45	SSR645DINAC45		
			65	SSR665DINAC45		
90–140 Vac	48–660 Vac	SPST-NO	45	SSR645DINAC45		
			65	SSR665DINAC45		

**SSRDIN Specifications (UL 508)**

Part Number	SSR210DINAC22	SSR220DINAC22	SSR230DINAC22	SSR245DINAC45	SSR610DINAC22
<b>Input Characteristics</b>					
Input Voltage Range	10/20/30 A: 4–32 Vdc; 45/65 A: 3–32 Vdc			10/20/30 A: 90–280 Vac; 45/65 A: 90–140 Vac	
Maximum Turn-On Voltage	4 Vdc			90 Vrms	
Minimum Turn-Off Voltage	1 Vdc			10 Vrms	
Typical Input Current	8–12 mA	9–11 mA	8–12 mA	2–4 mA	
<b>Output Characteristics</b>					
Output Type	SCR	MOSFET	SCR		
Switching Type	AC Zero Cross	DC Switching	AC Zero Cross		
Output Voltage	24–280 Vac	0–60 Vdc	48–660 Vac	24–280 Vac	48–660 Vac
Load Current Range	10–45 A	10–30 A	10–45 A		
Transient Overvoltage	600 Vpk	N/A	1200 Vpk	600 Vpk	1200 Vpk
Maximum Surge Current	10 A: 120 Apk; 20 A: 250 Apk; 30/45 A: 625 Apk (at 16.6 ms)	10 A: 30 Apk; 20 A: 60 Apk; 30 A: 90 Apk (at 10 ms)	625 Apk (at 16.6 ms)	10 A: 120 Apk; 20 A: 250 Apk; 30/45 A: 625 Apk (at 16.6 ms)	625 Apk (at 16.6 ms)
Maximum On-State Voltage Drop at Rated Current	1.6 Vpk	10 A: 0.2 Vpk; 20 A: 0.4 Vpk; 30 A: 0.5 Vpk	1.6 Vpk	1.6 Vpk	1.6 Vpk
Maximum I <sup>2</sup> t For Fusing, (8.3 ms)	10 A: 60 A <sup>2</sup> sec; 20 A: 260 A <sup>2</sup> sec; 30/45 A: 1620 A <sup>2</sup> sec	N/A	1620 A <sup>2</sup> sec	10 A: 60 A <sup>2</sup> sec; 20 A: 260 A <sup>2</sup> sec; 30/45 A: 1620 A <sup>2</sup> sec	1620 A <sup>2</sup> sec
Maximum Off-State Leakage Current at Rated Voltage	10 mA	0.1 mA	1 mA	10 mA	1 mA
Maximum Rate of Rise Off-State Voltage (dv/dt)	500 V/us	N/A	500 V/us		
Maximum Response Time (On and Off)	1/2 cycle	1.0 ms	1/2 cycle		
Maximum On-State Resistance	N/A	10 A: 20 mΩ; 20 A: 18 mΩ; 30 A: 16 mΩ	N/A		

Dimensions, in. (mm)

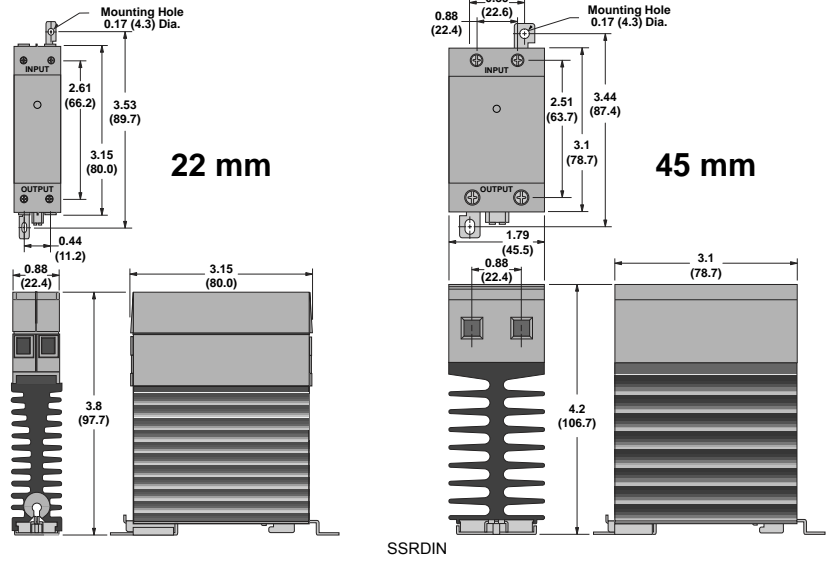

Wiring Diagram

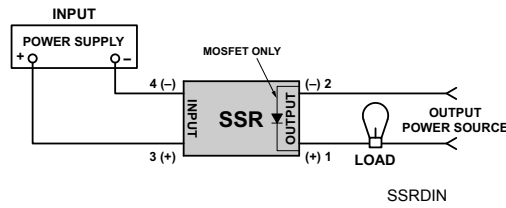

22 mm		45 mm	
input	output	input	output
6 mm <sup>2</sup>	4 mm <sup>2</sup>	4 mm <sup>2</sup>	10 mm <sup>2</sup>
AWG 10	AWG 12	AWG 12	AWG 8

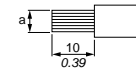

861 Solid-State Relays

861—SPST-NO, 8–15 A SPST-NC, 10 A



861 Relay

Switching Type	Switching Device	Input Voltage Range	Output Voltage Range	Contact Configuration	Rated Output Current (A)	Standard Part Number	
DC Switching	MOSFET	3.5–32 Vdc	3–50 Vdc	SPST-NO	15	861SSR115DD	
			3–150 Vdc	SPST-NO	8	861SSR208DD	
AC Random	Triac	3–32 Vdc	24–280 Vac	SPST-NO	8	861SSRA208DC2	
			24–280 Vac	SPST-NC	8	861SSRA208DC4	
			48–480 Vac	SPST-NO	8	861SSRA408DC2	
			48–480 Vac	SPST-NO	8	861SSRA408AC2	
	SCR	3–32 Vdc	24–280 Vac	24–280 Vac	SPST-NO	10	861SSR210DC2
				24–280 Vac	SPST-NC	10	861SSR210DC4
				48–480 Vac	SPST-NO	10	861SSR410DC2
				48–480 Vac	SPST-NO	10	861SSR410AC2
		90–280 Vac	24–280 Vac	24–280 Vac	SPST-NO	10	861SSR210AC2
				48–480 Vac	SPST-NO	10	861SSR410AC2
				48–600 Vac	SPST-NO	10	861SSR610AC2
				24–280 Vac	SPST-NO	10	861SSR210AC1
AC Zero Cross	Triac	3–32 Vdc	24–280 Vac	SPST-NO	8	861SSRA208DC1	
			48–480 Vac	SPST-NO	8	861SSRA408DC1	
			24–280 Vac	SPST-NO	8	861SSRA208AC1	
			48–480 Vac	SPST-NO	8	861SSRA408AC1	
	SCR	3–32 Vdc	24–280 Vac	24–280 Vac	SPST-NO	10	861SSR210DC1
				48–480 Vac	SPST-NO	10	861SSR410DC1
				48–600 Vac	SPST-NO	10	861SSR610DC1
				24–280 Vac	SPST-NO	10	861SSR210AC1
		90–280 Vac	24–280 Vac	48–480 Vac	SPST-NO	10	861SSR410AC1
				48–600 Vac	SPST-NO	10	861SSR610AC1
				24–280 Vac	SPST-NO	10	861SSR210AC1
				48–600 Vac	SPST-NO	10	861SSR610AC1

861 Specifications (UL 508)

Part Number	861SSR--DD	861SSRA--DC	861SSR--DC-4	861SSRA--AC	861SSR--AC
<b>Input Characteristics</b>					
Input Voltage Range	3.5–32 Vdc		3–32 Vdc		90–280 Vac
Must Release Voltage	1 Vdc				10 Vac
Nominal Input Impedance	Current regulator				16–25 kW
Typical Input Current at 5 Vdc	12mA		16 mA; 12 mA (861SSR210-DC-4)		12mA
Reverse Polarity Protection	Yes				N/A
<b>Output Characteristics</b>					
Switching Device	MOSFET	Triac	SCR	Triac	SCR
Switching Type	DC Switching		AC Zero Cross; AC Random		
Contact Configuration	SPST-NO		SPST-NO; SPST-NC		
Output Voltage Range	3–50 Vdc; 3–150 Vdc		24–280 Vac; 48–480 Vac; 48–600 Vac		
Maximum Rate of Rise, Off-State Voltage (dv/dt)	N/A	250 V/us	500 V/us; 350 V/us (861SSR410, 861SSR610-DC-1); 200 V/us (861SSR210-DC-4, 861SSR610-DC-2)	250 V/us	500 V/us; 350 V/us (861SSR410); 250 V/us (861SSR610)
Current Ratings	Load rating: 8 A rms, 15 A rms	Load rating: 8 A (rms) Incandescent lamp rating: 5 A (rms) Motor load rating: 3 A (rms)	Load rating: 10 A (rms) Incandescent lamp rating: 8 A (rms) Motor load rating: 4.5 A (rms)	Load rating: 8 A (rms) Incandescent lamp rating: 5 A (rms) Motor load rating: 3 A (rms)	Load rating: 10 A (rms) Incandescent lamp rating: 8 A (rms) Motor load rating: 4.5 A (rms)
Minimum Load Current—Maintain On	20mA	150mA	50 mA	150mA	50 mA
Non-Replicative Surge Current (1 cycle)	861SSR115-DD: 35 A; 861SSR208-DD: 50 A	200 A	500 A	200 A	500 A
Maximum RMS Overload Current (1 s)	861SSR115-DD: 17 A; 861SSR208-DD: 24 A	24 A			
Maximum Off-State Leakage Current	0.25 mA	10 mA (rms)			
Typical On-State Voltage Drop	N/A	1.25 Vac (rms)			
Maximum On-State Voltage Drop	0.5 Vdc	1.6 Vac (rms)			
Maximum On-State Resistance	40 mW	N/A			
Maximum Turn-On Time	5 ms	8.3 ms			
Maximum Turn-Off Time	5 ms	8.3 ms			
Maximum I <sup>2</sup> T for Fusing	N/A	250 A <sup>2</sup> sec	1250 A <sup>2</sup> sec (861SSR210); 850 A <sup>2</sup> sec (861SSR410); 600 A <sup>2</sup> sec (861SSR610)	250 A <sup>2</sup> sec	1250 A <sup>2</sup> sec (861SSR210); 850 A <sup>2</sup> sec (861SSR410); 600 A <sup>2</sup> sec (861SSR610)

Dimensions, in. (mm)

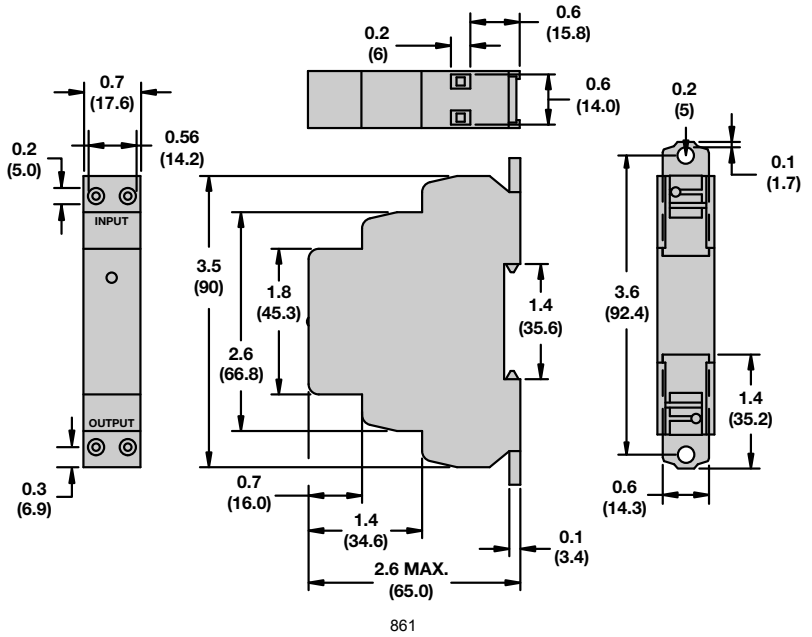

Wiring Diagram

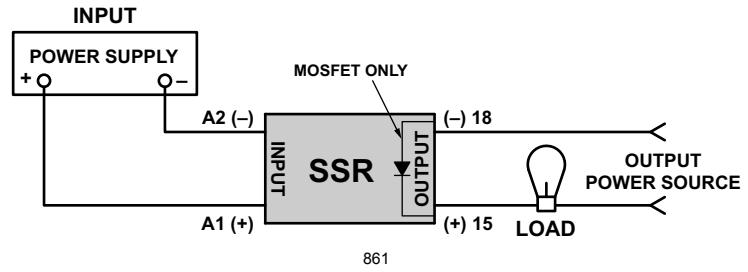



70S2 (V) Relay



70S2 (F) Relay



70S2 (S) Relay



70S2 (M) Relay



70S2 (N) Relay

## 70S2 Solid-State Relays

### 70S2—SPST-NO, 3–25 A

Part Number	70S201A	70S202A	70S203B	70S203C
<b>Input Characteristics</b>				
Control Voltage Range	3–15 Vdc	9–30 Vdc	3–30 Vdc	
Must Release Voltage	1 Vdc			
Typical Input Current	5–40 mA	5–17 mA	7–16 mA	6–10 mA
Maximum Reverse Control Voltage	3 Vdc			
<b>Output Characteristics</b>				
Switching Device	MOSFET		TRIAC	
Switching Type	DC Switching		AC Zero Cross	
Contact Configuration	SPST-NO			
Output Voltage Range	3–60 Vdc		24–140 Vac	24–280 Vac
Peak Blocking Voltage	105 Vdc		400 Vac	600 Vac
Maximum Rate of Rise Off-State Voltage (dv/dt)	N/A		300 V/us	
Output Current Range (rms)	3–5 A	5 A	25 A	25 A
Minimum Load Current—Maintain On	N/A		100 mA	
Non-Repetitive Surge Current (8.3 ms)	3 A: 5 A (1 s); 5 A: 7 A (1 s)		300 A	
Maximum Off-State Leakage Current (rms)	10 mA		6 mA	
Typical On-State Voltage Drop (rms)	3 A: 1.2 Vdc; 5 A: 1.85 Vdc		1.7 Vac	
Maximum Turn-On Time	75 ms		8.3 ms	
Maximum Turn-Off Time	3 A: 500 ms; 5 A: 75 ms		8.3 ms	

### 70S2 Specifications (UL 508)

Part Number	70S201A	70S202A	70S203B	70S203C
<b>Input Characteristics</b>				
Control Voltage Range	3–15 Vdc	9–30 Vdc	3–30 Vdc	
Must Release Voltage	1 Vdc			
Typical Input Current	5–40 mA	5–17 mA	7–16 mA	6–10 mA
Maximum Reverse Control Voltage	3 Vdc			
<b>Output Characteristics</b>				
Switching Device	MOSFET		TRIAC	
Switching Type	DC Switching		AC Zero Cross	
Contact Configuration	SPST-NO			
Output Voltage Range	3–60 Vdc		24–140 Vac	24–280 Vac
Peak Blocking Voltage	105 Vdc		400 Vac	600 Vac
Maximum Rate of Rise Off-State Voltage (dv/dt)	N/A		300 V/us	
Output Current Range (rms)	3–5 A	5 A	25 A	25 A
Minimum Load Current—Maintain On	N/A		100 mA	
Non-Repetitive Surge Current (8.3 ms)	3 A: 5 A (1 s); 5 A: 7 A (1 s)		300 A	
Maximum Off-State Leakage Current (rms)	10 mA		6 mA	
Typical On-State Voltage Drop (rms)	3 A: 1.2 Vdc; 5 A: 1.85 Vdc		1.7 Vac	
Maximum Turn-On Time	75 ms		8.3 ms	
Maximum Turn-Off Time	3 A: 500 ms; 5 A: 75 ms		8.3 ms	

### 70S2 Specifications (UL 508) Continued

Part Number	70S204B	70S204C	70S204D	70S205C	70S206C
<b>Input Characteristics</b>					
Control Voltage Range	3 A: 3–32 Vdc; 4/6/10/12 A: 3–30 Vdc			6–30 Vdc	3–30 Vdc
Must Release Voltage	1 Vdc				
Typical Input Current	3 A: 1–19 mA; 4/6/10/12 A: 7–16 mA			6–10 mA	1–17 mA
Maximum Reverse Control Voltage	3 Vdc				
<b>Output Characteristics</b>					
Switching Device	TRIAC				
Switching Type	AC Zero Cross				
Contact Configuration	SPST-NO				
Output Voltage Range	24–140 Vac	24–280 Vac	8–50 Vac	24–280 Vac	
Peak Blocking Voltage	400 Vac	600 Vac	200 Vac	600 Vac	
Maximum Rate of Rise Off-State Voltage (dv/dt)	300 V/us				
Output Current Range (rms)	3–12 A	3–12 A	3 A	12 A	
Minimum Load Current—Maintain On	3/4/6 A: 75 mA; 10/12 A: 100 mA				
Non-Repetitive Surge Current (8.3 ms)	3/4/6 A: 60 A; 10/12 A: 150 A				
Maximum Off-State Leakage Current (rms)	6 mA		10 mA	6 mA	
Typical On-State Voltage Drop (rms)	1.6 Vac				
Maximum Turn-On Time	8.3 ms				
Maximum Turn-Off Time	8.3 ms				

Dimensions, in. (mm)

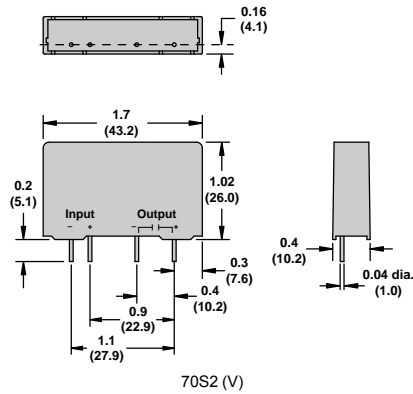
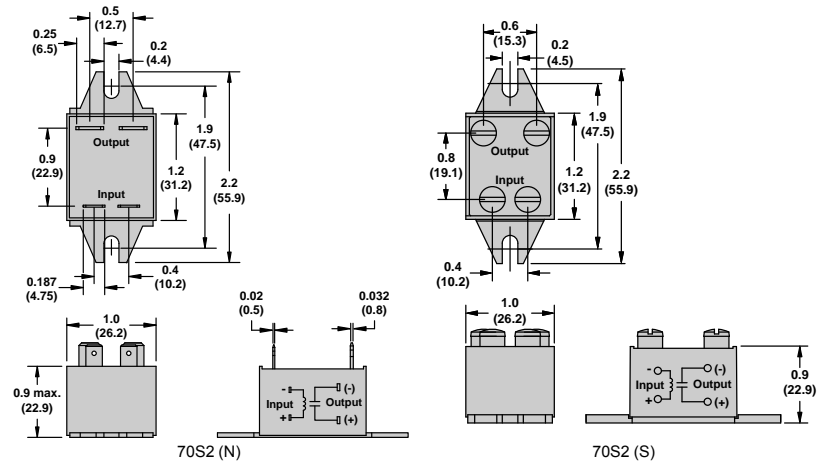
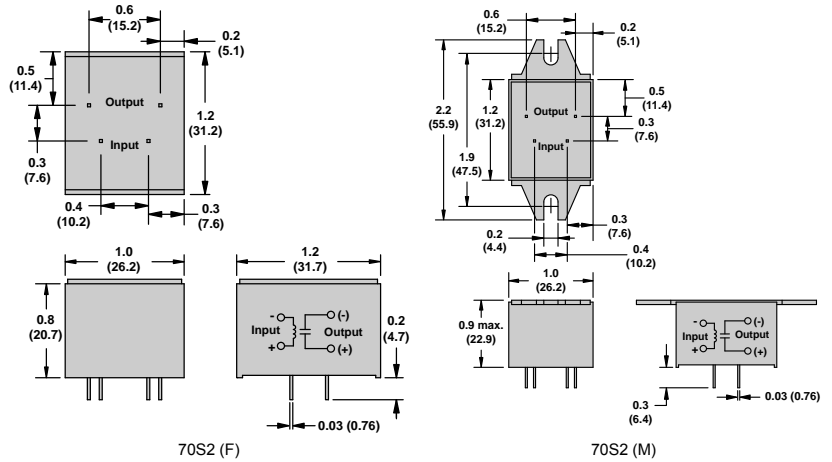

Wiring Diagram

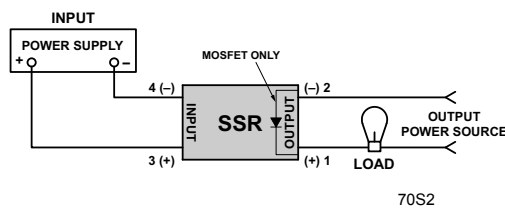

22 mm		45 mm	
input	output	input	output
6 mm <sup>2</sup>	4 mm <sup>2</sup>	10 mm <sup>2</sup>	8 mm <sup>2</sup>
AWG 10	AWG 12	AWG 8	AWG 10

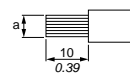



CAD32

### TeSys™ D IEC Style Instantaneous Control Relays

These 600 V relays are approved for use around the world. TeSys D relays are usually mounted on 35 mm DIN track, but can also be mounted directly to a panel. The contacts have NEMA A600 and Q600 ratings, in addition to the standard IEC ratings, making them suitable for use in most any control circuit. Low consumption versions are available for use with low level DC control signals from a computer or a PLC. Adder decks can be added to a basic five pole relay to make it up to an 11 pole relay. The serrated silver-nickel contacts with wiping action provide excellent reliability in 12 or 24 V control circuits. Special auxiliary contacts are available for switching low power down to 5 V at 10 mA. Timer and mechanical latch attachments are available.

Table 23.84: Instantaneous Control Relays

Terminal Type	Number of Contacts	Contact Composition		Catalog Number <sup>[1]</sup>
		Normally Open	Normally Closed	
Screw Clamp	5	5	0	CAD50
		3	2	CAD32
Spring Terminal	5	5	0	CAD503
		3	2	CAD323
Ring Tongue	5	5	0	CAD506
		3	2	CAD326

Table 23.85: Coil Voltage Codes:  
12–240 Vac, 12–72 Vdc, 5–72 Vdc Low Consumption<sup>[2]</sup>

AC 50/60 Hz Coil (for additional voltage code options see page 7 of Catalog 8501CT0101).						
Volts	12	24	48	120	208	240
Code	J7	B7	E7	G7	LE7	U7
DC Coil (coils have built in suppression as standard)						
Volts	12	24	36	48	60	72
Code	JD	BD	CD	ED	ND	SD
DC Low Consumption Coil (coils have built in suppression as standard)						
Volts	5	12	24	48	72	
Code	AL	JL	BL	EL	SL	

Table 23.86: Coil Voltage Codes (cont.):  
277–600 Vac, 110–440 Vdc<sup>[2]</sup>

AC 50/60 Hz Coil (for additional voltage code options see page 7 of Catalog 8501CT0101).				
Volts	277	480	600	
Code	W7	T7	X7	
DC Coil (coils have built in suppression as standard)				
Volts	110	125	220	250 440
Code	FD	GD	MD	UD RD

Table 23.87: Instantaneous Auxiliary Contact Blocks (for use in normal operation environments)

Number of Contacts	Maximum Number per Device Clip-on Mounting		Termination Type	Contact Composition		Catalog Number
	Front	Left Side Only		Normally Open	Normally Closed	
2	1	—	Screw Clamp	2	0	LADN20
				1	1	LADN11
				0	2	LADN02
	—	1 Not for DC devices	Spring Terminal	2	0	LADN203
				1	1	LADN113
				0	2	LADN023
4 <sup>[3]</sup>	1	—	Screw Clamp	2	0	LADN40
				3	1	LADN31
				2	2	LADN22
				1	3	LADN13
				0	4	LADN04
				4	0	LADN403
	—	1	Spring Terminal	3	1	LADN313
				2	2	LADN223
				1	3	LADN133
				0	4	LADN043
				2	2	LADC22
				2	2	LADC223

Table 23.88: Instantaneous Auxiliary Contacts with Dust and Damp Protected Contacts (for use in harsh industrial environments)

Number of Contacts	Maximum Number per Device	Contact Composition					Catalog Number	
		Sealed	[5]	Normal				
2	1	2	—	—	—	—	LA1DX20	
		—	2	—	—	—	LA1DX02	
		2	—	2	—	—	LA1DY20	
4 <sup>[3]</sup>	1	2	—	—	2	—	LA1DZ40	
		2	—	—	—	1	1	LA1DZ31
		2	—	—	—	—	—	

### Approvals for TeSys D IEC Style Instantaneous Control Relays



File: E164353  
CCN: NKCR



File: LR43364  
Class: 3211 03



- For replacement AC coils, see TeSys™ D and F Overload Relay Accessories, page . DC coils are not replaceable.

[1] Add the proper voltage code from Table 23.85 or Table 23.86 to the end of the catalog number. For example, CAD50B7.  
 [2] Add the proper voltage code to the end of catalog number.  
 [3] Auxiliary contact blocks with four contacts cannot be used on relays with low consumption coils.  
 [4] Includes 1 N.O. and 1 N.C. overlapping contact.  
 [5] Grounding terminal points (2 terminals jumpered together; see diagram on page 8 of Catalog 8501CT0101).

TeSys™ D IEC Style Contact Blocks and Accessories

Table 23.89: Time Delay Auxiliary Contact Blocks

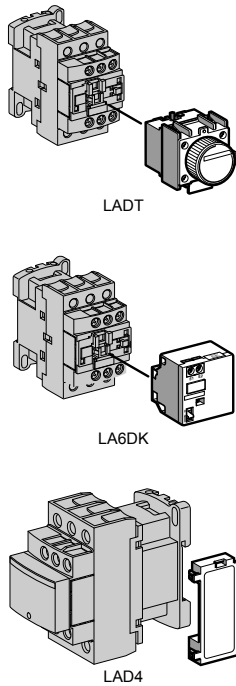

Number and Type of Contacts	Maximum Number per Device	Time Delay Type	Termination Type	Range	Catalog Number
	Front Mounting				
1 N.C. and 1 N.O.	1	On-Delay	Screw Clamp	0.1–3 s [6]	LADT0
				0.1–30 s	LADT2
				10–180 s	LADT4
			Spring Terminal	1–30 s [7]	LADS2
				0.1–3 s [6]	LADT03
				0.1–30 s	LADT23
		Off-Delay	Screw Clamp	10–180 s	LADT43
				1–30 s [7]	LADS23
				0.1–3 s [6]	LADR0
			Spring Terminal	0.1–30 s	LADR2
				10–180 s	LADR4
				0.1–3 s [6]	LADR03
			0.1–30 s	LADR23	
			10–180 s	LADR43	

NOTE: For Lockout Cover, see page 7 of catalog 8501CT0101.

Table 23.90: Mechanical Latch Blocks [8]

Unlatching Control	Maximum Number per Device	Catalog Number[9]
	Front Mounting	
Manual or electrical	1	LAD6K10

Table 23.91: Coil Suppressor Modules

These modules clip onto the right hand side of the control relay and the electrical connection is instantly made. Adding an input module is still possible.

RC Circuits (Resistor-Capacitor)

- Effective protection for circuits highly sensitive to "high frequency" interference.
- Voltage limited to 3 Uc maximum and oscillating frequency limited to 400 Hz maximum.
- Slight increase in drop-out time (1.2 to 2 times the normal time).

For Mounting On:	Operational Voltage	Catalog Number
CAD (Vac)	24 to 48 Vac	LAD4RCE
	110 to 240 Vac	LAD4RCU

Varistors (Peak Limiting)

- Protection provided by limiting the transient voltage value to 2 Uc maximum.
- Maximum reduction of transient voltage peaks.
- Slight increase in drop-out time (1.1 to 1.5 times the normal time).

CAD (Vac)	24 to 48 Vac	LAD4VE
	50 to 127 Vac	LAD4VG
	110 to 250 Vac	LAD4VU

Bidirectional Peak Limiting Diode

- Protection provided by limiting the transient voltage value to 2 Uc maximum.
- Maximum reduction of transient voltage peaks.

CAD (Vac)	24 Vac	LAD4TB
	72 Vac	LAD4TS

Table 23.92: Coil Voltage Codes

Volts (Vac/Vdc)	24	32/36	42/48	60/72	100	110/127	220/240
Code	B	C	E	EN	K	F	M

Table 23.93: Dimensions (See Figures at Left)

	CAD (Vac Coil)	in. (mm)			CAD (Vdc Coil or Low Consumption Vdc Coil)	in. (mm)	
		32 50	323 503			32 50	323 503
b		3.03 (77)	3.90 (99)	b		3.03 (77)	3.90 (99)
c	Without cover or add-on blocks	3.31 (84)	3.31 (84)	c	Without cover or add-on blocks	3.66 (93)	3.66 (93)
	With cover, without add-on blocks	3.39 (86)	3.39 (86)		With cover, without add-on blocks	3.74 (95)	3.74 (95)
c1	with LADN or C (2 or 4 contacts)	4.61 (117)	4.61 (117)	c1	with LADN or C (2 or 4 contacts)	4.96 (126)	4.96 (126)
c2	with LA6DK10	5.08 (129)	5.08 (129)	c2	with LA6DK10	5.43 (138)	5.43 (138)
c3	with LADT, R, S	5.39 (137)	5.39 (137)	c3	with LADT, R, S	5.75 (146)	5.75 (146)
	with LADT, R, S and sealing cover	5.55 (141)	5.55 (141)		with LADT, R, S and sealing cover	5.91 (150)	5.91 (150)

Dimensions (in./mm)

CAD (Vac Coil)

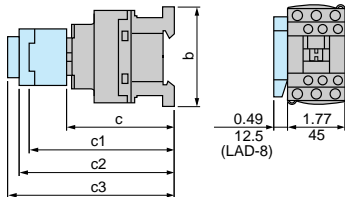

CAD (Vdc Coil or Low Consumption Vdc Coil)

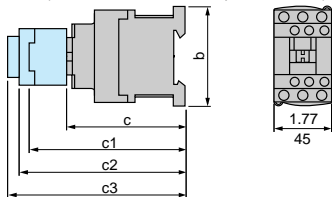

[6] With extended scale from 0.1 to 0.6 s.

[7] With switching time of 40 ms ± 15 ms between opening of the N.C. contact and closing of the N.O. contact.

[8] Power should not be simultaneously applied or maintained to the mechanical latching block and the CAD relay. The duration of the control signal to the mechanical latching block and the CAD relay should be greater than or equal to 100 ms.

[9] Complete the catalog number by adding the coil voltage code from Table 23.92. For example, LADK10B.

## TeSys™ D IEC Style Accessories

Table 23.94: Cabling Accessory

Description		Catalog Number	
Mounting Adapter For adapting existing wiring to a new product	Without coil suppression	LAD4BB	
	With coil suppression	24 to 48 Vac	LAD4BBVE
		50 to 127 Vac	LAD4BBVG
		110 to 250 Vac	LAD4BBVU

Table 23.95: Electronic Serial Timer Modules [10]

On-Delay Type		
Mounted using adaptor LAD4BB, to be ordered separately, see listing above.		
Operational Voltage	Time Delay	Catalog Number
24 to 250 Vac	0.1 to 2 s	LA4DT0U
	1.5 to 30 s	LA4DT2U
	25 to 500 s	LA4DT4U

Table 23.96: Auto-Man-Stop Control Modules

For local override operation tests with two-position "Auto-Man" switch and "O-I" switch	
Mounted using adaptor LAD4BB, to be ordered separately, see listing above.	
Operational Voltage	Catalog Number
24 to 100 Vac	LA4DMK

Table 23.97: Accessories (ordered separately)

Description	For Mounting On:	Must be Ordered in Multiples of:	Catalog Number
<b>For Marking</b>			
Sheet of 64 self-adhesive blank labels 8 x 33	CAD, LAD (4 contacts), LA6DK	10	LAD21
Sheet of 112 self-adhesive blank labels 8 x 12	LAD (2 contacts), LADT	10	LAD22
<b>For Protection</b>			
Lockout cover	LADT, LADR	1	LA9D901
Relay cover preventing access to the moving contact carrier	CAD	1	LAD9ET1

Table 23.98: Application Data

Type	CAD (Vac)	CAD (Vdc)	CAD (Vdc) Low Consumption
Rated Insulation Voltage (Ui)	Conforming to IEC 60947-1-1 Overvoltage category III and degree of pollution 3	690 V	690 V
	Conforming to UL, CSA	600 V	600 V
Rated Impulse Withstand Voltage (Uimp)	Conforming to IEC 60947-1-1	6 kV	6 kV
Separation of Electrical Circuits	To IEC 536 and VDE 0106	Reinforced insulation up to 400 V	
Conforming to Standards	IEC 60947-1-1, N-F C 63-140, VDE 0660, BS 4794, EN 60947-5-15		
Approvals	UL: File: E164353 CSA: File: LR43364 CE	CCN: NKCR Class: 3211 03	
Protective Treatment	Conforming to IEC 60068	"TH" (Tropical Finish). See page 23 of Catalog 8501CT0101 for details.	
Degree of Protection	Conforming to VDE 0106	Front face protected against direct finger contact IP 2X	Protection against direct finger contact

[10] For 24 V operation, the relay must be fitted with a 21 V coil (code Z7).



CA2KN22



CA2KN403



CA4KN405



CA3KN407

**TeSys™ K IEC Style Control Relays**

- Mounting on 35 mm DIN 3 track or 4 screw direct mounting.
- Screws in open “ready-to-tighten” position
- NEMA A600, Q600
- IEC AC15, DC13

**Table 23.99: Control Relays**

Control Circuit		Type of Termination	Contact Configuration		Catalog Number [11]
			N.O.	N.C.	
Supply	Consumption				
AC	4.5 VA	Screw clamp	4	0	CA2KN40 **
			3	1	CA2KN31 **
			2	2	CA2KN22 **
		Spring Termination	4	0	CA2KN403 **
			3	1	CA2KN313 **
			2	2	CA2KN223 **
		Faston 1 x 6.35 or 2 x 2.8	4	0	CA2KN407 **
			3	1	CA2KN317 **
			2	2	CA2KN227 **
		Solder pins for printed circuit board	4	0	CA2KN405 **
			3	1	CA2KN315 **
			2	2	CA2KN225 **
DC	3 W	Screw clamp	4	0	CA3KN40 **
			3	1	CA3KN31 **
			2	2	CA3KN22 **
		Spring Termination	4	0	CA3KN403 **
			3	1	CA3KN313 **
			2	2	CA3KN223 **
		Faston 1 x 6.35 or 2 x 2.8	4	0	CA3KN407 **
			3	1	CA3KN317 **
			2	2	CA3KN227 **
		Solder pins for printed circuit board	4	0	CA3KN405 **
			3	1	CA3KN315 **
			2	2	CA3KN225 **

**Table 23.100: Low Consumption Control Relays**

Compatible with programmable controller outputs.

- LED indicator incorporated.
- Wide range coil (70 to 130% Uc), suppressor fitted as standard.
- Mounting on 35 mm DIN 3 track or 4 screw direct mounting.
- Screws in open “ready-to-tighten” position.

Control Circuit		Type of Termination	Contact Configuration		Catalog Number [12]
			N.O.	N.C.	
Supply	Consumption				
DC	1.8 W	Screw clamp	4	0	CA4KN40 ***
			3	1	CA4KN31 ***
			2	2	CA4KN22 ***
		Spring Termination	4	0	CA4KN403 ***
			3	1	CA4KN313 ***
			2	2	CA4KN223 ***
		Faston 1 x 6.35 or 2 x 2.8	4	0	CA4KN407 ***
			3	1	CA4KN317 ***
			2	2	CA4KN227 ***
		Solder pins for printed circuit board	4	0	CA4KN405 ***
			3	1	CA4KN315 ***
			2	2	CA4KN225 ***

[11] Complete the catalog number by adding the proper voltage code from Table 23.101, Table 23.102, Table 23.103, or Table 23.104. For example, CA2KN40G7.

[12] Complete the catalog number by adding the proper voltage code from Table 23.105. For example, CA4KN40BW3.

**Table 23.101: Coil Voltage Codes for CA2K Control Relays (0.8–1.15 Uc) (0.85–1.10 Uc)—12 to 220/230 Vac 50/60 Hz**

Voltage	12 Vac	24 Vac	36 Vac	42 Vac	48 Vac	110 Vac	120 Vac	127 Vac	208 Vac	220/230 Vac
Code	J7	B7	C7	D7	E7	F7	G7	FC7	L7	M7

**NOTE:** Up to and including 240 V, coil with integral suppression device available: add 2 to the code required. Example: **J72**.

**Table 23.102: Coil Voltage Codes for CA2K Control Relays (0.8–1.15 Uc) (0.85–1.10 Uc)—230 to 660/690 Vac 50/60 Hz**

Voltage	230 Vac	230/240 Vac	380/400 Vac	400 Vac	400/415 Vac	440 Vac	480 Vac	500 Vac	660/690 Vac
Code	P7	U7	Q7	V7	N7	R7	T7	S7	Y7

**NOTE:** Up to and including 240 V, coil with integral suppression device available: add 2 to the code required. Example: **J72**.

**Table 23.103: Coil Voltage Codes for CA3K Control Relays (0.8–1.15 Uc)—12 to 72 Vdc**

Voltage	12 Vdc	20 Vdc	24 Vdc	36 Vdc	48 Vdc	60 Vdc	72 Vdc
Code	JD	ZD	BD	CD	ED	ND	SD

**NOTE:** Coil with integral suppression device available: add 3 to the code required. Example: **JD3**.

**Table 23.104: Coil Voltage Codes for CA3K Control Relays (0.8–1.15 Uc)—100 to 250 Vdc**

Voltage	100 Vdc	110 Vdc	125 Vdc	200 Vdc	220 Vdc	230 Vdc	240 Vdc	250 Vdc
Code	KD	FD	GD	LD	MD	MPD	MUD	UD

**NOTE:** Coil with integral suppression device available: add 3 to the code required. Example: **JD3**.

**Table 23.105: Coil Voltage Codes for CA4K, Low Consumption Control Relays (Wide Range Coil: 0.7–1.3 Uc)**

Voltage	12 Vdc	24 Vdc	48 Vdc	72 Vdc
Code	JW3	BW3	EW3	SW3

**Approvals for TeSys K IEC Style Control Relays**



File: E164353  
CCN: NKCR



File: LR43364  
Class: 3211 03



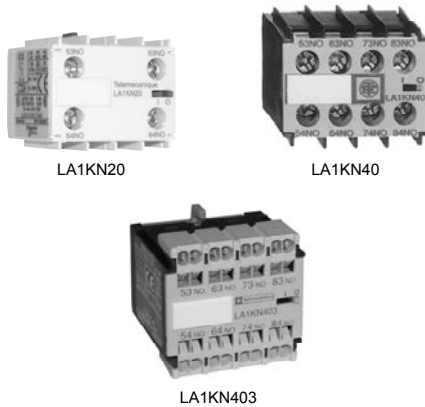

Approximate Dimensions for LA2KT Electronic Time Delay Contact Blocks (in./mm)

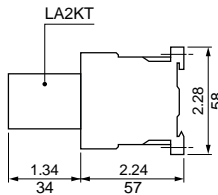

Approximate Dimensions for CA2, CA3, CA4K Control Relays (in./mm) On Panel

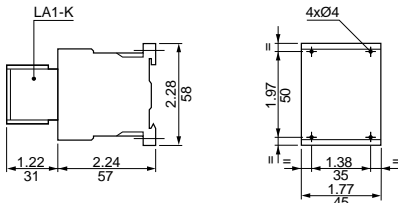

On Printed Circuit Board

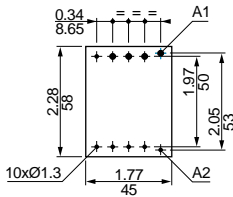

TeSys™ K IEC Style Contact Blocks and Accessories

Table 23.106: Instantaneous Auxiliary Contact Blocks [13][14]

Type of Connection	Clip-on Front Mounting, 1 Block Per Control Relay		Catalog Number
	Contact Configuration		
	N.O.	N.C.	
Screw Clamp	2	0	LA1KN20
	0	2	LA1KN02
	1	1	LA1KN11
	4	0	LA1KN40[15]
	3	1	LA1KN31[15]
	2	2	LA1KN22[15]
	1	3	LA1KN13[15]
	0	4	LA1KN04[15]
Spring Termination	2	0	LA1KN203
	1	1	LA1KN113
	0	2	LA1KN023
	4	0	LA1KN403[15]
	3	1	LA1KN313[15]
	2	2	LA1KN223[15]
	1	3	LA1KN133[15]
	0	4	LA1KN043[15]
Faston 1 x 6.35 or 2 x 2.8	2	0	LA1KN207
	0	2	LA1KN027
	1	1	LA1KN117
	4	0	LA1KN407[15]
	3	1	LA1KN317[15]
	2	2	LA1KN227[15]
	1	3	LA1KN137[15]
	0	4	LA1KN047[15]

Table 23.107: Clip-On Front Mounting, 1 Block per Control Relay

Voltage	Type	Timing Range (s)	Composition C.O.	Catalog No.
AC or DC: 24 to 48	On-delay	1 to 30 s	1	LA2KT2E
AC: 110 to 240	On-delay	1 to 30 s	1	LA2KT2U

Table 23.108: Electronic Time Delay Contact Blocks

Relay output, with common point changeover contact	240 Vac/Vdc, 2 A maximum
Control voltage	0.85–1.1 Uc
Maximum switching capacity	250 VA or 150 W
Operating temperature	-10 to +60°C (+14° F to 140° F)
Reset time	1.5 s during the time delay period, 0.5 s after the time delay.

NOTE: For other electronic timers, see Type JCK60 and JCK70 Timers, page 23-110.

Table 23.109: Accessories (supplied separately)

Description	Sold in lots of	Catalog No.
Marker holder [16]	100	LA9D90
Clip-on markers [16]	25	AB1R* [16]
		AB1G* [16]
Suppressor modules with locating device. No tools required for connection.	5	LA4KE1B [17]
		LA4KE1E [17]
		LA4KE1FC [17]
		LA4KE1UG [17]
		LA4KC1B [18]
		LA4KA1U [19]

Table 23.110: Environment

Conforming to Standards		IEC 947, NF C 63-140, VDE 0660, BS 5424, CE
Approvals		UL, CSA, DEMKO, NEMKO, SEMKO, FI
Protective treatment	Conforming to IEC 68 (DIN 50016)	"TC" (Climateproof)
Degree of protection	Conforming to VDE 0106	Protection against direct finger contact
Ambient air temperature	Storage	-58 to 176 °F (-50 to 80°C)
	Operation	-13 to 122 °F (-25 to 50°C)
Max. operating altitude	Without derating	6562 ft (2000 m)

[13] Clip-on front mounting, 1 block per control relay.

[14] Auxiliary contact module not suitable for safety circuits.

[15] Not to be used on CA4KN relays.

[16] See "Clip-in Marker Strips" in Catalog 8501CT0101 for information on completing the catalog number.

[17] Protection by the limitation of the transient voltage to 2 Uc maximum. Maximum reduction of the transient voltage peaks. Slight time delay on drop-out (1.1 to 1.5 times normal).

[18] No overvoltage or oscillation frequency. Polarized component. Slight time delay on drop-out (1.1 to 1.5 times normal).

[19] Protection by limitation of the transient voltage to 3 Uc max. and limitation of the oscillation frequency. Slight time delay on drop-out (1.2 times to twice normal).

**TeSys™ SK IEC Style Control Relays**

- Miniature size saves space.
- Up to 4 poles.
- Mounts on 35 mm DIN 3 track.



CA2SK11G7



LA1SK11



CA2SKE20

**Table 23.111: IEC Style Industrial Control Relays**

Control Circuit Supply	Consumption	Type of Termination	Contact Configuration		Catalog Number [20]
			N.O.	N.C.	
AC	4.2 VA	Screw clamp	1	1	CA2SK11 ••
			2	0	CA2SK20 ••
DC	2.2 W		1	1	CA3SK11 ••
			2	0	CA3SK20 ••

**Table 23.112: Contact Adder Decks (for CA2SK20 only)**

Type of Termination	Contact Configuration		Catalog Number
	N.O.	N.C.	
Screw clamp	2	0	LA1SK20
	1	1	LA1SK11
	0	2	LA1SK02

**Transient Suppressor Module** dampens the voltage spike that may occur when the relay coil is de-energized. The spike may adversely affect solid state equipment near the relay. The transient suppressor module snaps into a cavity located in the side of the relay. These modules can be used with CA2SK and CA3SK relays.

**Table 23.113: Transient Suppressor Module**

Control Circuit Voltage	Catalog Number
24–48 Vac 50/60 Hz, 24–48 Vdc	LA4SKEIE
110–250 Vac 50/60 Hz, 110–250 Vdc	LA4SKEIU

**Table 23.114: Coil Voltage Codes for Control Relays**

Voltage	12	24	36	48	72	110	120	220	230	240	277	380	400	480
50/60 Hz	—	B7 [21]	—	E7 [21]	—	F7	G7 [21]	M7 [21]	P7	U7 [21]	UE7	Q7	V7	T7 [21]
DC	JD	BD	CD	ED	SD	—	—	—	—	—	—	—	—	—

**IEC Style Alternating Relays** are used to alternate the use of 2 motor circuits. When the coil is energized the first time, one contact closes and will open when the coil is de-energized. When the coil is energized again, the other contact will close and will open when the coil is de-energized. The contacts from these alternators are to be used in the control circuit of the starters that are controlling pump or compressor motors.

**Table 23.115: Alternating Relays**

Coil Voltage (Voltage-Hz)	Type
24–50/60	CA2SKE20 •• [22]

**Table 23.116: Contact Ratings for CA2SK, CA3SK, and CA2SKE20 Relays**

V	AC						DC	
	NEMA Rating	Inductive 35% PF		Continuous Amperes	Resistive 75% PF	V	Continuous Amperes	
		Make	Break					Make, Break and Continuous Amperes
120	A600	60	6	10	10	24	3	
240		30	3			60	2	
480		15	1.5			110	0.8	
600		12	1.2			240	0.2	

**Approximate Dimensions for CA2SKE Relay**

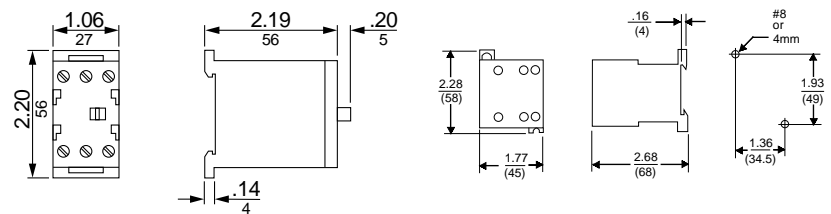

**Approvals for TeSys SK IEC Style Relays**

[20] Use the appropriate voltage code from Table 23.114 to complete the catalog number. For example, CA2SK11G7.  
 [21] Alternating relays CA2SKE available in these voltages only. No other voltages are available.  
 [22] Use the appropriate voltage code from Table 23.114 to complete the catalog number (for example, CA2SK11G7). Only available with voltages indicated in this table.



File: E164353  
CCN: NKCR



File: LR43364  
Class: 3211 03



8501XO40V02 AC Control Relay



8501XMO40V02 AC Master Relay

AC Control and Master Relays Dimensions

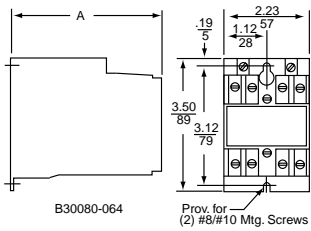

B30080-064

Dual Dimensions: INCHES  
Millimeters



8501XO40XTE1V02 AC Timing Relay

### Square D™ NEMA Style AC Relays

Class 8501 Type X relays combine a rugged, heavy-duty design with modular construction for greater flexibility. They are ideal for applications where long life, high reliability, and ease of maintenance are important. The Type X family offers a complete line of relays and accessories for most control applications. The 8501X relay consists of a standard 4 pole base to which it is possible to add additional contacts, timer, and latch functionality. Instantaneous and Master contacts are converted from N.O. to N.C. by flipping the contact cartridge within the base. The 8501X relay can either be built from individual part numbers or ordered pre-assembled.

#### AC Control Relays

- Straight-through wiring
- Plug-in contact cartridges for easy contact conversion and replacement
- Contact conversion without removing terminal screws or wires
- Self-lifting pressure wire connectors
- Replaceable coil

Table 23.117: AC Control Relays (lots of 1)

No. of N.O. 10 A Convertible Instantaneous Contacts <sup>[1]</sup>	Type <sup>[1][2]</sup>
0	XO00
2	XO20
3	XO30
4	XO40
6	XO60
8	XO80
10	XO1000
12	XO1200

#### AC Master Relays

- 20 ampere contact rating due to use of master contact cartridges.<sup>[3]</sup>
- Provisions for standard cartridges to be used in contact cavities not occupied by master cartridges in 2-8 pole AC relay.

Table 23.118: AC Master Relays

No. of N.O. 20 A Convertible Contacts	Type <sup>[2][4]</sup>
2	XMO20
4	XMO40
6	XMO60

Table 23.119: Dimension A (See Figure at Left) and Weights

No. of Poles	Dim. A		Shipping Weight, lb
	in.	mm	
0-4	3.95	100	2.0
6-8	5.16	131	2.3
10-12	6.36	162	2.7

#### AC Timing Relays

- Easily convertible On or Off Delay
- Two adjustable timing ranges
- Repeat accuracy well above ±10%
- Convertible 1 N.O. and 1 N.C. timed contacts
- Large knob for easy adjustment of time delay
- Off Delay mode times out even after loss of power

Table 23.120: AC Timing Relays (lots of 1)

Timing Mode	No. of N.O. 10 A Convertible Instantaneous Contacts	Timed Convertible Contacts		Timing Relay	
		N.O.	N.C.	0.2-60 s	5-180 s
				Type <sup>[2]</sup>	Type <sup>[2]</sup>
On Delay	0	1	1	XO00XTE1	XO00XTE2
	2	1	1	XO20XTE1	XO20XTE2
	4	1	1	XO40XTE1	XO40XTE2
Off Delay	0	1	1	XO00XTD1	XO00XTD2
	2	1	1	XO20XTD1	XO20XTD2
	4	1	1	XO40XTD1	XO40XTD2

[1] A maximum of 8 N.C. contacts is allowed on 9-12 pole relays.

[2] Voltage code must be specified to order these products. Refer to Table 23.124 and insert the code as shown in Table 23.125.

[3] Maximum of six 8501 Type XC4 master cartridges may be used on only 7 and 8 pole AC devices.

[4] Attachments not permitted on this relay.



8501XO40XLV02 Latching Relay

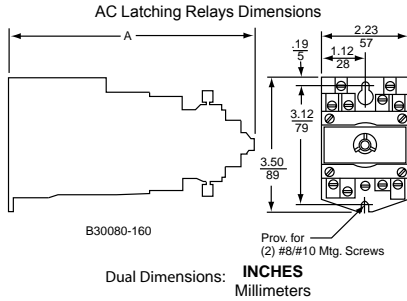

Dual Dimensions: **INCHES**  
Millimeters

**AC Latching Relays**

- Mechanical latch holds all contacts switched even after removal of power from replaceable latching coil.
- Provides sequence memory in the event of power loss. Ideal for press control, process control, and punch presses.
- Replaceable unlatch coil to switch contacts back to original state.

**Table 23.121: AC Latching Relays (lots of 1)**

N.O. 10 A Convertible Instantaneous Contacts	Latching Relay
	Type [5]
2	XO20XL
3	XO30XL
4	XO40XL
6	XO60XL
8	XO80XL

**Table 23.122: Dimension A (See Figure at Left) and Weights**

No. of Poles	Dim. A		Shipping Weight, lb
	in.	mm	
2-4	6.54	166	2.8
6-8	7.74	197	3.1

- For replacement coils, see Table 23.139.

**Table 23.123: AC Contact Ratings**

Type of Cartridge	V	NEMA Rating	Inductive 35% Power Factor				Continuous Amperes	Resistive 75% Power Factor Make, Break and Continuous Amperes
			Make		Break			
			A	VA	A	VA		
Standard or Overlapping	120	A600	60	7200	6	720	10	10
	240		30		3			
	480		15		1.5			
	600		12		1.2			
Master[6]	—	A600	Same as standard cartridge above except substitute 20 A for the continuous ampere rating					
Logic Reed	—	—	150 Vac, 150 mA, 8 W Maximum					

- For DC ratings, see Table 23.129.

**Table 23.124: Voltage Codes**

AC Voltages - Hz	Code
12-60	V11
24-60	V01
24-50	V12
48-60	V18
48-50	V16
120-60/110-50	V02
208-60	V08
240-60/220-50	V03
277-60	V04
480-60/440-50	V06
600-60/550-50	V07

**Table 23.125: How to Order**

To Order Specify:	Catalog Number		
• Class Number	<b>Class</b>	<b>Type</b>	<b>Voltage Code</b>
• Type Number	8501	XO40	V02
• Voltage Code			

**Approvals for Square D NEMA Style Relays**



File: E78403  
CCN: NKCR



File: 060905  
Class: 3211 03



IEC 60947-1

[5] Voltage code must be specified to order these products. Refer to Table 23.124 and insert the code as shown in Table 23.125.  
[6] Maximum of six 8501 Type XC4 master cartridges may be used on only 7 and 8 pole AC devices.



8501XDO40V53 Control Relay

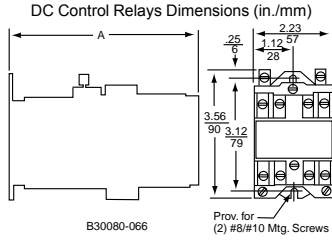

8501XDO40XTE2V53 Timing Relay

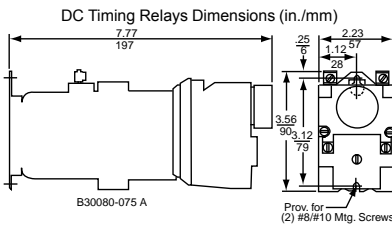

## Square D™ NEMA Style DC Relays

### DC Control Relays

- Replaceable, highly reliable pure DC power plant: no economizing resistors, overlapping contacts or dual-wound coil.
- Uses the same Type XB adder decks and attachments as the AC version.
- Offers all the features of the AC relay.
- Available in up to 8 poles.
- All contact poles are usable since no overlapping contacts are needed.

Table 23.126: DC Control Relays

Normally Open 5 A Convertible Instantaneous Contacts	Control Relay
	Type <sup>[7]</sup>
0	XDO00
2	XDO20
4	XDO40
6	XDO60
8	XDO80

Table 23.127: Dimension A (See Figure at Left) and Weights

No. of Poles	Dim. A		Shipping Weight lb.
	in.	mm	
0-4	5.17	131	3.1
6-8	6.37	162	3.4
10-12	7.60	193	3.8

### DC Timing Relays

- Easily convertible On Delay or Off Delay.
- Two adjustable timing ranges.
- Repeat accuracy well above ±10%.
- Convertible 1 N.O. and 1 N.C. timed contacts.
- Large knob for easy adjustment of time delay.
- Off Delay mode times out even after loss of power.

Table 23.128: DC Timing Relays

Timing Mode	Normally Open 5 A Convertible Instantaneous Contacts	Timed Convertible Contacts		Timing Relay <sup>[7]</sup>	
		N.O.	N.C.	0.2-60 s	5-180 s
				Type	Type
On Delay	0	1	1	XDO00XTE1	XDO00XTE2
	2	1	1	XDO20XTE1	XDO20XTE2
	4	1	1	XDO40XTE1	XDO40XTE2
Off Delay	0	1	1	XDO00XTD1	XDO00XTD2
	2	1	1	XDO20XTD1	XDO20XTD2
	4	1	1	XDO40XTD1	XDO40XTD2

Table 23.129: DC Contact Ratings

Type of Cartridge	DC Ratings					
	Volts	Inductive			Resistive	
		NEMA Rating	Make and Break Amperes 138 VA Max.	Continuous Amperes	Make and Break Amperes	Continuous Amperes
Standard	125 250	P600	1.1 0.55	5 5	4 0.8	5 5
Overlapping	125	P150	1.1	5	4	5
Logic Reed	—	—	30 Vdc, 60 mA	—	—	—

- For AC ratings, see Table 23.123.

**NOTE:** Do not use any 8501 Type XC4 Master Cartridges on any DC-operated device.

[7] Voltage code must be specified to order these products. Refer to Table 23.133 and insert the appropriate code as shown in Table 23.134.



8501XDO40XDLV53 Latching Relay

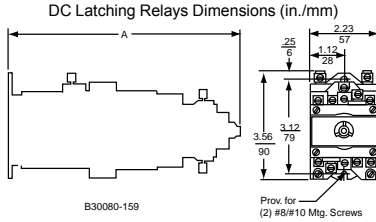

8501XUDO40V53 Utility Relay

**DC Latching Relays**

- Mechanical latch holds all contacts switched even after removal of power from replaceable latching coil.
- Provides sequence memory in the event of power loss.
- Ideal for sequencing applications such as press control, process control and punch presses.
- Replaceable unlatch coil to switch contacts back to original state.

**Table 23.130: DC Latching Relays**

Normally Open 5 A Convertible Instantaneous Contacts	Latching Relay [8]
	Type
2	XDO20XDL
4	XDO40XDL
6	XDO60XDL
8	XDO80XDL

**NOTE:** Unlatch coil is rated for intermittent duty and should be connected through a N.O. contact of the relay if the input signal is maintained. Order one more N.O. contact than the application requires to use as a coil clearing contact.

**Table 23.131: Dimension A (See Figure at Left) and Weights**

No. of Poles	Dim. A		Shipping Weight, lb.
	in.	mm	
2–4	7.76	197	3.9
6–8	8.98	228	4.2

**DC Utility Relays**

Ideal for utility plant applications where reliable performance and a pure DC power plant is required. In addition to the Type XDO relay features, the Type XUDO provides:

- Up to 12 poles N.O. or N.C.
- Nominal 125 Vdc coil, capable of handling 140 Vdc continuously and picking up at 105 Vdc after having been operated at 140 Vdc continuously. Other voltages with comparable operating characteristics are available.
- Enclosed device capable of operating in 145°F ambient.

**Table 23.132: DC Utility Relays**

Number of 5 A Convertible Contacts		Open Type[8]
N.O.	N.C.	Type
4	0	XUDO40
0	4	XUDO04
8	0	XUDO80
0	8	XUDO08
12	0	XUDO1200
0	12	XUDO0012

**Table 23.133: Voltage Codes—8501 XUDO and XDO Relays**

DC Voltages for 8501 XUDO Relays ONLY		Code	DC Voltages for 8501 XDO Relays		Code
6		V50	6		V50
12		V51	12		V51
24		V53	24		V53
48		V56	32		V54
125		V63	48		V56
250		V67	72		V58
—		—	90		V59
—		—	115/125		V62
—		—	230/250		V66

**Table 23.134: How to Order**

To Order Specify:	Catalog Number		
	Class	Type	Voltage Code
<ul style="list-style-type: none"> <li>• Class Number</li> <li>• Type Number</li> <li>• Voltage Code</li> </ul>	8501	XDO40	V53

- For replacement coils, see [Table 23.138](#).
- For UL and CSA approvals, see [Square D NEMA Style AC Relays](#).

[8] Voltage code must be specified to order these products. Refer to [Table 23.133](#) and insert the appropriate code as shown in [Table 23.134](#).

### Attachments and Accessories for Square D™ NEMA Style Relays

Table 23.135: Type X™ Relays







	Description	Type
	<p><b>Mechanical Latch Attachment</b>—Mounts on any 2 through 8-pole relay (except XMO master relay). The Type XL and XDL latch attachments are identical in size and mounting provisions. The Type XLAC latch attachment has a continuous-duty-rated coil which is replaceable. <b>The Type XDLDC latch attachment has an intermittent-rated coil (replaceable) and should be connected through a N.O. contact of the basic relay if the input signal is maintained to the unlatch coil.</b>                      AC Latch Attachment                      DC Latch Attachment</p>	XL [9] XDL[9]
	<p><b>Pneumatic Timer Attachment</b>—Mounts only on any 0 through 4-pole AC or DC relays (except XMO master relay). It provides 1 N.O. and 1 N.C. convertible timed contacts, which are the same Type XC1 cartridges used on the basic relay. Two timing ranges are available, and conversion from On Delay to Off Delay or vice versa is easy.  <b>Off Delay</b>                      0.2–60 seconds                      5–180 seconds  <b>On Delay</b>                      0.2–60 seconds                      5–180 seconds</p>	XTD1 XTD2 XTE1 XTE2
	<p><b>Timer Lockout Cover</b>—Fits over the time delay adjustment knob of any Type XT timing attachment. The Lockout Cover is designed to protect the time setting against accidental adjustment. It mounts directly to the timing attachment with two included screws.</p>	XJ1
	<p><b>Adder Decks</b>—Adder decks are used to expand the number of poles on a relay. The basic 4-pole relay can be easily converted to an 8-pole or 12-pole relay by installing one or two adder decks. The Class 8501 Type XB20 comes with 2 convertible contact cartridges and will accept 2 additional convertible contact cartridges. The Class 8501 Type XB40 comes with 4 convertible contact cartridges. The same Type XB adder deck is used for both the middle and upper decks of the AC or DC relay.</p> <p>With 2 N.O. contact cartridges</p> <p>With 4 N.O. contact cartridges</p>	XB20  XB40
	<p><b>Contact Cartridges</b>—The Type X relay offers 4 Types of contact cartridges. All are color-coded for visual identification of each Type.</p> <p><b>Standard Cartridge</b>—The standard cartridge, used for most applications, has a black case.</p> <p><b>Overlapping Cartridge</b>—Same NEMA Type A600 AC rating as standard cartridge and a NEMA Type P150 DC rating. When it is used in the N.O. mode it will close early and when used in the N.C. mode it will open late. If two or more are used together, the N.O. contacts will close before the N.C. contacts open as the relay picks up. Overlap also occurs during dropout. Overlapping cartridge has a red case.</p> <p>May be ordered factory installed:</p> <ul style="list-style-type: none"> <li>Substitute 1 N.O. and 1 N.C. overlapping cartridges for 2 standard cartridges.</li> <li>Substitute 2 N.O. and 2 N.C. overlapping cartridges for 4 standard cartridges.</li> <li>Substitute 3 N.O. and 3 N.C. overlapping cartridges for 6 standard cartridges.</li> <li>Substitute 4 N.O. and 4 N.C. overlapping cartridges for 8 standard cartridges.</li> </ul> <p><b>Master Cartridge</b>—Features the same contact ratings as the Type XC1 standard cartridge except it has a 20 ampere continuous current rating instead of 10 amperes. It can be used in circuits where a master relay is required. Master cartridge has a blue case. <b>Maximum of 6 master cartridges may be used on any 7 and 8-pole AC relays. Do not use any master cartridges on 9-12-pole AC or any DC-operated devices. Note: If master cartridges are added to a standard relay, attachments (latch mechanism, timers, etc.) cannot be used.</b></p>	XC1 XC2  Form Y1591 Y1592 Y1593 Y1594  XC4
	<p><b>Mounting Track</b>—The mounting track has pre-punched mounting holes to simplify mounting the track on the control panel. The relay mounting screws are factory installed on the track so that the relays can be hung prior to tightening the screws.</p> <p>9 in. long for 4 relays                      18 in. long for 8 relays                      27 in. long for 12 relays                      36 in. long for 16 relays</p>	XM4 XM8 XM12 XM16
	<p><b>Manual Test Tool</b>—Provides a means of manually switching the contacts of a basic relay or timing relay and holding all contacts in their switched state until the tool is removed. This simplifies the checking of control circuits without power on the coil or contacts.</p> <p><b>Transient Suppressor</b>—Consists of an R-C circuit designed to suppress coil generated transients to approximately 200 percent of peak voltage. It is particularly useful when switching the Type X relay near solid state equipment. It is designed for use on coils up to 120 Vac.</p>	XA1  XS1
	<p><b>NEMA 1 Enclosure</b>—Formed from sheet steel to provide strength and rigidity. Two conduit knockouts are located in both the top and bottom of the enclosure. The enclosure is furnished with self tapping screws for mounting the relay inside the enclosure. Accommodates a single 4 or 8-pole AC or DC relay, 12-pole AC relay, 4-pole AC latching relay, and 4-pole AC timing relay.</p> <p><b>NOTE:</b> The 4-pole DC latching relay, 4-pole DC timing relay, 8-pole AC and DC latching relays and 12-pole utility auxiliary relay will not fit.</p>	Class 9991 Type UE7

Table 23.136: Mechanical Latch Attachment Voltage Codes

AC Voltage	Code	DC Voltage	Code
24–60	V01	6	V50
24–50	V12	12	V51
120–60/110–50	V02	18	V99
208–60	V08	24	V53
240–60/220–50	V03	48	V56
277–60	V04	72	V58
480–60/440–50	V06	90	V59
600–60/550–50	V07	115/125	V62
		230/250	V66

Table 23.137: How to Order

To Order Specify:	Catalog Number	
<ul style="list-style-type: none"> <li>Class Number</li> <li>Type Number</li> <li>Voltage Code for mechanical latch attachment</li> <li>Form for factory installed overlapping contacts</li> </ul>	Class  8501	Type  XTE1

[9] See Table 23.136.

**Table 23.138: DC Relay Coil Selection**

Equipment To Be Serviced		Coil Prefix, or Class and Type	Hz	Suffix (The complete coil number consists of prefix or the Class and Type, followed by suffix.)													Coil Burden Watts
Class	Type			6 V	12 V	18 V	24 V	32 V	48 V	64 V	72 V	90 V	110 V	115/125 V	220 V	230/250 V	
8501	XD	9998 XD	—	19	28	34	37	40	46	49	52	55	—	58	—	67	18
	XDL	9998 XDL	—	19	28	34B	37B	40B	46B	49B	52B	55B	—	58B	—	67B	50
	XUD	9998 XUD	—	19	28	—	37	—	46	—	—	—	—	58 [10]	—	67 [11]	16

**Table 23.139: AC Relay Coil Selection**

Equipment To Be Serviced		Coil Prefix or Class and Type	—	Suffix (The complete coil number consists of prefix or the Class and Type, followed by suffix.)												Coil Volt-Amperes	
Class	Type			24 V	110-115 V	120 V	208 V	220 V	240 V	277 V	380 V	440 V	480 V	550 V	600 V	In-rush	Sealed
8501	XO, XMO	9998 X [12]	60	23	—	44	51	52	53	55	—	—	62	—	65	148	23
			50	24	44	—	52	53	—	—	—	62	—	65	—	—	143

[10] 125 Vdc only

[11] Not dual rated—250 Vdc only

[12] To order an unlatch coil, add the letter L to the type number and the letter B to the suffix number. Example: for a 120 V 60 Hz unlatch coil, order a Class 9998 Type XL44B.



RE17LAMW



RE17LMBM



RE17RLMU

### Zelio™ RE17, E22 and RENF22 Modular Timers

The Zelio RE17, RE22 and RENF22 modular timer range is comprised of both 8 A relay and 0.7 A solid state outputs. Thanks to its space saving 17.5 mm design, this relay is ideal for applications that require a lot of control in a small foot print. The RE17 series is designed to attach to a 35 mm DIN rail.

- Multifunction, dual function, or single function
- Multi-range (7 selectable ranges)
- Multivoltage
- Solid state or relay output options

**Table 23.140: RE17 Series Timers**

Supply Voltage	Timing Ranges	Output Type	Rated Current	Functions	Function Descriptions [1]	Catalog Number
24–240 Vac/ Vdc	0.1 s to 100 h	SPST Solid State	0.7 A	A	Power On delay	RE17LAMW
				H	Interval	RE17LHBM
24–240 Vac	0.1 s to 100 h	SPST Solid State	0.7 A	C	Off delay with control signal	RE17LCBM
				L, Li	Asymmetrical flasher	RE17LLBM
				A, At, B, C, H, Ht, D, Di, Ac, Bw	Multi-function	RE17LMBM
				B	Interval with control signal	RE17RBMU
24 Vdc, 24–240 Vac	0.1 s to 100 h	SPDT Relay	8 A	C	Off delay with control signal	RE17RCMU
				A, At	Power on delay	RE17RAMU
				H, Ht	Interval	RE17RHMU
				L, Li	Asymmetrical flasher	RE17RLMU
				A, At, B, C, H, Ht, D, Di, Ac, Bw	Multi-function	RE17RMMU
				Ad, Ah, N, O, P, Pt, T, Tt, W	Multi-function	RE17RMXMU
				A, At, B, C, H, Ht, D, Di	Multi-function	RE17RMEMU
				L, Li	Asymmetrical flasher	RE17RLJU
12 Vdc	0.1 s to 100 h	SPDT Relay	8 A	A, At, B, C, H, Ht, D, Di, Ac, Bw	Multi-function	RE17RMJU
				A, At, B, C, H, Ht, D, Di, Ac, Bw	Multi-function	RE17RMMW
12–240 Vac	0.1 s to 100 h	SPDT Relay	8 A	A, At, B, C, H, Ht, D, Di, Ac, Bw	Multi-function	RE17RMMWS

[1] For detailed function definitions, see Table 23.147.

**Table 23.141: RE22 Series Timer References**

Timing Ranges	Functions	No. of relay outputs	Voltages V	Reference	Weight kg/lb
<b>Single function</b>					
10 selectable timing ranges 1 s, 3 s, 10 s, 30 s, 100 s, 300 s, 30 min, 300 min, 30 h, 300 h	Ac	2	24...240	RE22R2ACMR	0.105/ 0.231
	Qg	2	24...240	RE22R2QGMR	0.105/ 0.231
	Qt	2	24...240	RE22R2QTMR	0.105/ 0.231
7 selectable timing ranges 1 s, 3 s, 10 s, 30 s, 100 s, 300 s, 10 min	K	1	24...240	RE22R1KMR <sup>[2][3]</sup>	0.100/ 0.220
		2	24...240	RE22R2KMR <sup>[2][3]</sup>	0.100/ 0.220
7 selectable timing ranges 0.5 s, 1 s, 3 s, 10 s, 30 s, 100 s, 300 s	Qc	1	24/24...240	RE22R1QCMU	0.080/ 0.176
Single range selection 30 s	Qe	2	24...240	RE22R2QEMR	0.090/ 0.198
		2	380...415	RE22R2QEMT	0.090/ 0.198
<b>Dual function</b>					
10 selectable timing ranges 1 s, 3 s, 10 s, 30 s, 100 s, 300 s, 30 min, 300 min, 30 h, 300 h	A, Aw	1	24...240	RE22R1AMR	0.100/ 0.220
		2	24...240	RE22R2AMR	0.105/ 0.231
	C, Ct	1	24...240	RE22R1CMR	0.100/ 0.220
	C	2	24...240	RE22R2CMR	0.105/ 0.231
	Ac, Act	1	24...240	RE22R1ACMR	0.100/ 0.220
	Ak, Akt	1	24...240	RE22R1AKMR	0.100/ 0.220
		1	24...240	RE22R1DMR	0.100/ 0.220
	D, Dw	2	24...240	RE22R2DMR	0.105/ 0.231
		1	24...240	RE22R1HMR	0.100/ 0.220
		2	24...240	RE22R2HMR	0.105/ 0.231
7 selectable timing ranges 0.5 s, 1 s, 3 s, 10 s, 30 s, 100 s, 300 s	K, He	1	24...240	RE22R1MKMR <sup>[2][3]</sup>	0.100/ 0.220
10 selectable timing ranges 1 s, 3 s, 10 s, 30 s, 100 s, 300 s, 30 min, 300 min, 30 h, 300 h	A, At, Aw	1	24...240	RE22R1MAMR	0.100/ 0.220
	A, At, Aw, Ac, Act, C, Ct, D, Dt, Dw, Di, Dit, Diw, H, Ht, Hw, W, Wt	1	24...240	RE22R1MYMR	0.100/ 0.220
	A, At, Aw, C, Ct, D, Dt, Dw, Di, Dit, Diw, H, Ht, Hw, Qg, Qgt, Qt, Qtt, W, Wt	2	24...240	RE22R2MYMR	0.105/ 0.231
	L, Li, Lt, Lit	1	24...240	RE22R1MLMR	0.100/ 0.220
<b>Multifunction</b>					
7 selectable timing ranges 1 s, 10 s, 1 min, 10 min, 1 h, 10 h, 100 h	Q	1	24/24...240	RE22R1QMU	0.090/ 0.198
		1	230-380	RE22R1QMQ	0.090/ 0.198
<b>Dual function</b>					
7 selectable timing ranges 1 s, 10 s, 1 min, 10 min, 1 h, 10 h, 100 h	A, At	2	24/24...240	RE22R2AMU	0.090/ 0.198
<b>Multifunction</b>					
7 selectable timing ranges 1 s, 10 s, 1 min, 10 min, 1 h, 10 h, 100 h	A, At, B, C, H, Ht, Di, D, Ac, Bw	2	24/24...240	RE22R2MMU	0.090/ 0.198
			12	RE22R2MJU	0.090/ 0.198
	Ad, Ah, N, O,P, Pt, Tl, Tt, W	2	12...240	RE22R2MMW	0.090/ 0.198
			24/24...240	RE22R2MXMU	0.090/ 0.198

**Approvals for RE17 Timers**



File: E173076  
CCN: NRNT, NRNT7



File: 248382  
Class: 3211-06



IEC 61812-1

RoHS Compliant

[2] The diagnostic button is not available for the K function related references (RE22R1KMR, RE22R2KMR, and RE22R1MKMR).  
[3] 1 or 2 relay outputs: 5 A - 250 V.



RE48ATM12MW



RE48AMH13MW



RUZC3M



RE48ASOC11AR



RE48ASOC8SOLD



RE48ASOC11SOLD



RE48ASETCOV



RE48AIPCOV

### Zelio™ RE48 Panel Mount Timers

The Zelio RE48 panel mount timer range is comprised of 5 A relay outputs. The unit can be mounted either on a panel or on a DIN rail with the optional octal socket. Thanks to the large selector knob, the user can quickly and easily see the current value selected and change it if needed.

- Time unit selector knob
- Multifunction, single function, or dual function
- 1.2 second to 300 hour timing range
- Wide input voltage range
- 5 A relay outputs
- Panel-mounted or plug-in
- LED indication

Table 23.142: RE48 Series Timers

Supply Voltage	Timing Ranges	Pin Configuration	Output Type	Rated Current	Functions	Function Descriptions [4]	Catalog Number
24–240 Vac/Vdc	1.2 s to 300 h	8–Pin Octal	DPDT Relay	5 A	A	Power On delay	RE48ATM12MW
					A1, A2, H1, H2	Delay On Energization, Pulse-on Energization	RE48AMH13MW
24–240 Vac/Vdc	1.2 s to 300 h	11–Pin Octal	DPDT Relay	5 A	L, Li	Asymmetrical flasher	RE48ACV12MW
					A, B, C, Di	Multi-function	RE48AML12MW

Table 23.143: Sockets (sold in lots of 10)

Description	Connection	Compatibility	Catalog Number
Mixed 8–Pin DIN Rail Mountable Socket	Box lug connector, DIN rail mount	RE48ATM12MW, RE48AMH13MW	RUZC2M
Mixed 11–Pin DIN Rail Mountable Socket		RE48ACV12MW, RE48AML12MW	RUZC3M
Mixed 11–Pin Mountable Socket	Box lug connector	RE48ACV12MW, RE48AML12MW	RE48ASOC11SOLD
Mixed 8–Pin Solder Connector	Solder connectors	RE48ATM12MW, RE48AMH13MW	RE48ASOC8SOLD
Mixed 11–Pin Solder Connector	Solder connectors	RE48ACV12MW, RE48AML12MW	RE48ASOC11SOLD

Table 23.144: Accessories (sold in lots of 10)

Description	Compatibility	Catalog Number
Setting protective cover	RE48 Series Timers	RE48ASETCOV
Protective cover IP64		RE48AIPCOV

### Approvals for RE48 Timers



File: E173076  
CCN: NRNT2, NRNT8



File: 248382  
Class: 3211 07



IEC 61812-1

RoHS Compliant

[4] For detailed function definitions, see Table 23.147.

### Zelio™ REXL Miniature Plug-In Timers

The Zelio REXL miniature plug-in timer range is comprised of DPDT and 4PDT single On-delay function timers. The unit is designed to be mounted in a socket in a panel. Thanks to the large selector knob, the user can quickly and easily see the current value selected and change it if needed. Features include:

- Miniature and plug-in (21 x 27 mm / 0.827 x 1.062 in.)
- Single function: function A = delay on energization
- Rated current at 5 A
- 7 timing ranges (0.1 s to 100 h)
- Multivoltage
- Excellent immunity to interference
- Power on and relay energized indication by 2 LEDs



REXL2TM



REXL4TM



RXZE2M114M



RXZE2S114M

Table 23.145: REXL Series Timers

Supply Voltage	Timing Ranges	Pin Configuration	Output Type	Rated Current	Functions	Function Descriptions [5]	Catalog Number
12 Vdc	0.1 s to 100 h	8-Pin Quick Connect (Blade)	DPDT Relay	5 A	A	Power On delay	REXL2TMJD
24 Vdc	0.1 s to 100 h	8-Pin Quick Connect (Blade)	DPDT Relay	5 A	A	Power On delay	REXL2TMBD
24 Vac	0.1 s to 100 h	8-Pin Quick Connect (Blade)	DPDT Relay	5 A	A	Power On delay	REXL2TMB7
120 Vac	0.1 s to 100 h	8-Pin Quick Connect (Blade)	DPDT Relay	5 A	A	Power On delay	REXL2TMF7
230 Vac	0.1 s to 100 h	8-Pin Quick Connect (Blade)	DPDT Relay	5 A	A	Power On delay	REXL2TMP7
12 Vdc	0.1 s to 100 h	14-Pin Quick Connect (Blade)	4PDT Relay	5 A	A	Power On delay	REXL4TMJD
24 Vdc [6]	0.1 s to 100 h	14-Pin Quick Connect (Blade)	4PDT Relay	5 A	A	Power On delay	REXL4TMBD
24 Vac [6]	0.1 s to 100 h	14-Pin Quick Connect (Blade)	4PDT Relay	5 A	A	Power On delay	REXL4TMB7
120 Vac	0.1 s to 100 h	14-Pin Quick Connect (Blade)	4PDT Relay	5 A	A	Power On delay	REXL4TMF7
230 Vac	0.1 s to 100 h	14-Pin Quick Connect (Blade)	4PDT Relay	5 A	A	Power On delay	REXL4TMP7

Table 23.146: Sockets (sold in lots of 10)

Contact Terminal Arrangement	Connection	For Use with Relays	Catalog Number
Mixed	Box lug connector	REXL2TM** REXL4TM**	RXZE2M114M
	Box lug connector	REXL2TM**	RXZES108M
Separate	Box lug connector	REXL4TM**	RXZE2S114M

### Approvals for REXL Timers



File: E173076  
CCN: NRNT2,  
NRNT8



File: 248382  
Class: 3211 07



IEC 61812-1

RoHS Compliant

Table 23.147: Timer Function Description

Function	Function Description [7]	Timer
A	Power on delay relay	RE17, RE48, REXL
A1, A2	Delay on energization	RE48
Ac	On-delay and off-delay relay with control signal	RE17
Ad	Pulse delayed relay with control signal	RE17
At	Power on delay relay (summation) with control signal	RE17
B	Interval relay with control signal	RE17, RE48
Bw	Double interval relay with control signal	RE17
C	Off-delay relay with control signal	RE17, RE48
D	Symmetrical flasher relay (starting pulse off)	RE17
Di	Symmetrical flasher relay (starting pulse on)	RE17, RE48
H	Interval relay	RE17
H1, H2	Pulse-on energization	RE48
Ht	Interval relay (summation) with control signal	RE17
L	Asymmetrical flasher relay (starting pulse off)	RE17, RE48
Li	Asymmetrical flasher relay (starting pulse on)	RE17, RE48
N	Retriggerable interval relay with control signal on	RE17
O	Retriggerable interval delayed relay with control signal on	RE17
P	Pulse delayed relay with fixed pulse length	RE17
Pt	Pulse delayed relay (summation and fixed pulse length) with control signal off	RE17
T	Bistable relay with control signal on	RE17
Tt	Retriggerable bistable relay with control signal on	RE17
W	Interval relay with control signal off	RE17

[5] For detailed function definitions, see Table 23.147.

[6] For 48 Vdc supply, additional resistor 560 ohms 2 W / 24 Vdc. For 48 Vac, additional resistor 390 ohms 4 W / 24 Vac.

[7] See catalog 9050CT0001 for timing diagrams and detailed descriptions.



821 Relay



822 Relay

820 Series Time Delay and Sensor Relays

820 Series—SPDT, 15 A; DPDT, 15 A

Input Voltage	Functions Available	Timing Range	Contact Configuration	Rated Current	Standard Part Number
12–240 Vac/Vdc	A,B,C,D,E,F,G,H,I,J	10 ms to 10 days SPDT	SPDT	15 A	821TD10HUNI
			DPDT	15 A (2 pairs of contacts)	822TD10HUNI

820 Specifications

Part Number	821TD10HUNI	822TD10HUNI
<b>Input Characteristics</b>		
Input Voltage Range	12–240 Vac/Vdc	12–240 Vac/Vdc
Operating Voltage (% of Nominal)	85% of 12 V to 110% of 240 V	85% of 12 V to 110% of 240 V
Maximum Power Consumption	3 VA 1.7W	3 VA 1.7W
<b>Output Characteristics</b>		
Contact Configuration	SPDT	DPDT
Output Current Rating	15 A	15 A
Contact Material	Silver alloy	Silver alloy
Switching Capability	N/A	
Minimum Switching Requirement	15 A @ 240 Vac, 50/60 Hz, 24 Vdc 1/2 hp @ 120 Vac 1 hp @ 240 Vac Pilot duty B300	15 A @ 240 Vac, 50/60 Hz, 24 Vdc 1/2 hp @ 120 Vac 1 hp @ 240 Vac Pilot duty B300
<b>Timing Characteristics</b>		
Functions Available	Multifunction	Multifunction
Time Scales	8	8
Time Ranges	100 ms to 1 s 1 s to 10 s 0.1 min to 1 min 1 min to 10 min 0.1 hr to 1 hr 1 hr to 10 hr 0.1 day to 1 day 1 day to 10 days	100 ms to 1 s 1 s to 10 s 0.1 min to 1 min 1 min to 10 min 0.1 hr to 1 hr 1 hr to 10 hr 0.1 day to 1 day 1 day to 10 days
Tolerance	5% of mechanical setting	5% of mechanical setting
Repeatability at Constant Voltage and Temperature	0.2%	0.2%
Reset Time	150 ms maximum	150 ms maximum
Trigger Pulse Length	50 ms minimum	50 ms minimum

Dimensions, in. (mm)

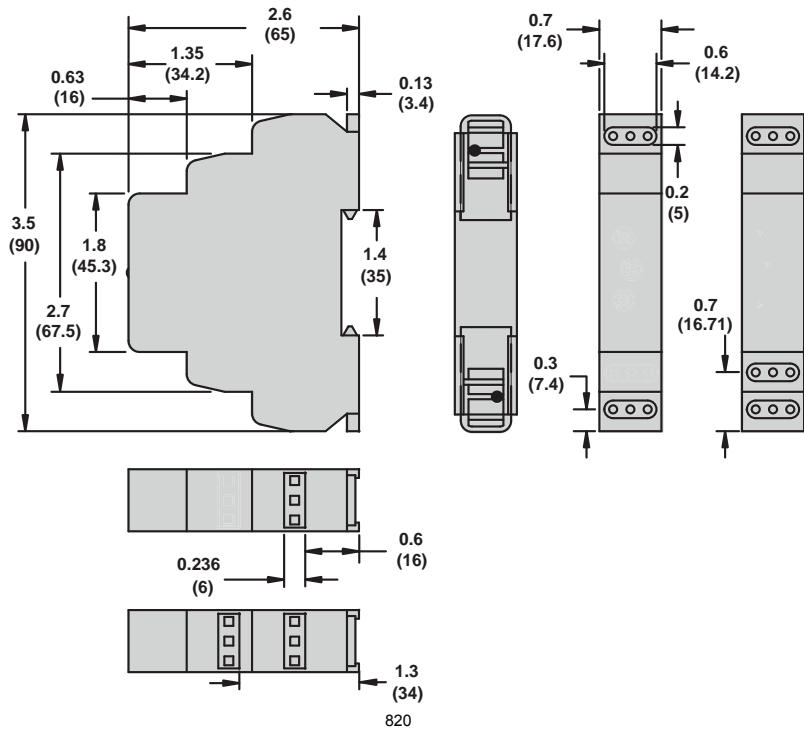

**Wiring Diagram**

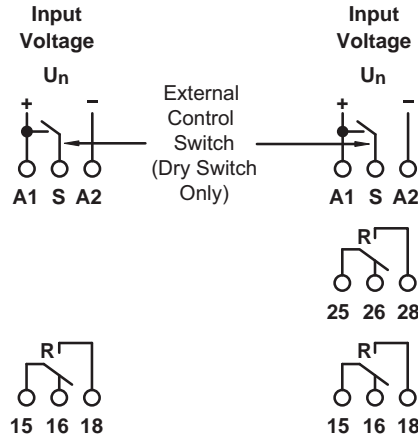

- 15—Common
- 16—Normally Closed
- 18—Normally Open
  
- 25—Common
- 26—Normally Closed
- 28—Normally Open

821TD10H-UNI

822TD10H-UNI

**TDR782 Series Time Delay and Sensor Relays**  
TDR782 Series—DPDT, 5 A; 4PDT, 3 A



TDR782 Relay

Input Voltage	Functions Available	Timing Range	Contact Configuration	Rated Current	Standard Part Number
<b>AC</b>					
24 Vac	A (On-Delay)	100 ms to 100 hr	4PDT	3 A	TDR782XDXA24A
			DPDT	5 A	TDR782XBXA24A
110 Vac	A (On-Delay)	100 ms to 100 hr	4PDT	3 A	TDR782XDXA110A
			DPDT	5 A	TDR782XBXA110A
230 Vac	A (On-Delay)	100 ms to 100 hr	4PDT	3 A	TDR782XDXA230A
<b>DC</b>					
12 Vdc	A (On-Delay)	100 ms to 100 hr	4PDT	3 A	TDR782XDXA12D
			DPDT	5 A	TDR782XBXA12D
24 Vdc	A (On-Delay)	100 ms to 100 hr	4PDT	3 A	TDR782XDXA24D
			DPDT	5 A	TDR782XBXA24D

**TDR782 Specifications**

Part Number	TDR782XB	TDR782XD
<b>Input Characteristics</b>		
Input Voltage Range	24, 110/120, 230/240 Vac 12, 24 Vdc	24, 110/120, 230/240 Vac 12, 24 Vdc
Operating Voltage	Vac	85–115% of nominal
	Vdc	90–110% of nominal
Maximum Power Consumption	1.7 VA @ 24 Vac 2.6 VA @ 120 Vac 3 VA @ 230 Vac 1.5 W @ 12 Vdc 1.2 W @ 24 Vdc	1.7 VA @ 24 Vac 2.6 VA @ 120 Vac 3 VA @ 230 Vac 1.5 W @ 12 Vdc 1.2 W @ 24 Vdc
<b>Output Characteristics</b>		
Contact Configuration	DPDT	4PDT
Output Current Rating	5 A	3 A
Contact Material	Silver alloy	Silver alloy
Maximum Inrush Current	10 A @ < 100 ms	10 A @ < 100 ms
Minimum Switching Requirement	100 mA at 5 Vac/Vdc	100 mA at 5 Vac/Vdc
<b>Timing Characteristics</b>		
Functions Available	Multifunction	Multifunction
Time Scales	7	7
Time Ranges	100 ms to 1 s 1 s to 10 s 0.1 min to 1 min 1 min to 10 min 0.1 hr to 1 hr 1 hr to 10 hr 10 hr to 100 hr	100 ms to 1 s 1 s to 10 s 0.1 min to 1 min 1 min to 10 min 0.1 hr to 1 hr 1 hr to 10 hr 10 hr to 100 hr
Tolerance	5% of mechanical setting	5% of mechanical setting
Repeatability at Constant Voltage and Temperature	0.5%	0.5%
Reset Time	50 ms maximum	50 ms maximum
Temperature Drift	0.05% /°C	0.05% /°C

Dimensions, in. (mm)

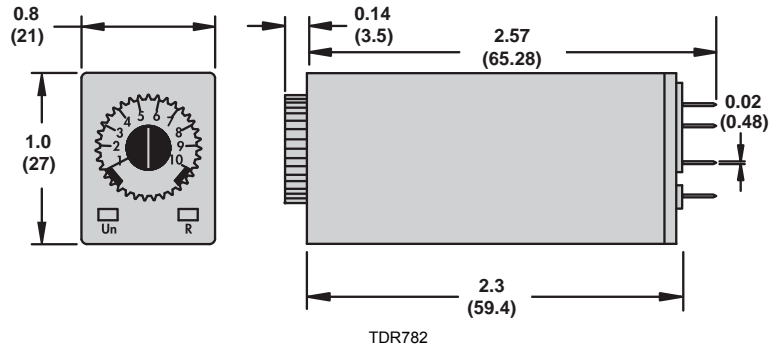

Wiring Diagram

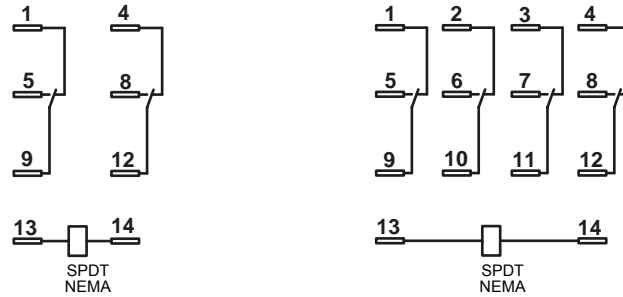

Relay Accessories

Description	Function	For Use With Relays	Packaging Quantities	Standard Part Number
Socket	Mounts directly to the DIN rail or panel	TDR782XBX	10	70782EL81
		TDR782XDX	10	70782EL141
	DIN or panel mounting with rising elevator box terminals	TDR782XBX	10	70782E141
		TDR782XDX		
	DIN or panel mounting with screw terminals and clamping plates	TDR782XBX	10	70782D141
		TDR782XDX		
TDR782XDX				
Solder terminals for chassis mounting	TDR782XBX	10	703781	
	TDR782XDX			
Printed circuit terminals	TDR782XBX	10	703791	
	TDR782XDX			
Metal Retention Clip	Helps secure the relay in the socket	TDR782**	10	16TDR782SC

Socket Accessories

Description	Function	For Use With Sockets	Packaging Quantities	Standard Part Number
Metal DIN Rail, 1 m (39.3 in.)	Quick installation and removal of sockets	See table above	10	16700DIN
DIN Rail End Clip	Holds sockets firmly in place on the DIN rail	—	10	16DCLIP1
ID Tags	Allows for identification of circuits in multi-relay applications	70782EL81	10	16782FT1
		70782EL141		
		70782E141		



TDRPRO Relay

**TDRPRO Series Time Delay and Sensor Relays**  
TDRPRO Series —SPDT, 12 A; DPDT, 12 A

Input Voltage	Timing Range	Functions Available	Contact Configuration	Rated Current	Standard Part Number
12–240 Vac/Vdc	100 ms to 9990 hr	A,B,C,D,E,F,G,H,I,J	DPDT	12 A	TDRPRO5100
		A,B,C,D,E,F,G,H,I,J	SPDT	12 A	TDRPRO5101
		A,B,C	DPDT	12 A	TDRPRO5102

**TDRPRO Specifications**

Part Number	TDRPRO5100	TDRPRO5101A	TDRPRO5102
<b>Input Characteristics</b>			
Input Voltage Range	12–240 Vac/Vdc	12–240 Vac/Vdc	12–240 Vac/Vdc
Operating Voltage	85–115% of nominal	85–115% of nominal	85–115% of nominal
Maximum Power Consumption (AC)	2.5 VA	2.5 VA	2.5 VA
Maximum Power Consumption (DC)	2 W	2 W	2 W
<b>Output Characteristics</b>			
Contact Configuration	DPDT	SPDT	DPDT
Output Current Rating	12 A	12 A	12 A
Contact Material	Silver alloy	Silver alloy	Silver alloy
Switching Capabilities	12 A, 240 Vac, 50/60 Hz, 30 Vdc 1/3 hp @ 120 Vac 1/2 hp @ 240 Vac Pilot duty B300	12 A, 240 Vac, 50/60 Hz, 30 Vdc 1/3 hp @ 120 Vac 1/2 hp @ 240 Vac Pilot duty B300	12 A, 240 Vac, 50/60 Hz, 30 Vdc 1/3 hp @ 120 Vac 1/2 hp @ 240 Vac Pilot duty B300
Minimum Switching Requirement	100 mA	100 mA	100 mA
<b>Timing Characteristics</b>			
Functions Available	A,B,C,D,E,F,G,H,I,J	A,B,C,D,E,F,G,H,I,J	A,B,C
Time Scales	7	7	7
Time Ranges	0–999 by 0.1 s 0–999 by 1 s 0–999 by 0.1 min 0–999 by 1 min 0–999 by 0.1 hr 0–999 by 1 hr 0–999 by 10 hr	0–999 by 0.1 s 0–999 by 1 s 0–999 by 0.1 min 0–999 by 1 min 0–999 by 0.1 hr 0–999 by 1 hr 0–999 by 10 hr	0–999 by 0.1 s 0–999 by 1 s 0–999 by 0.1 min 0–999 by 1 min 0–999 by 0.1 hr 0–999 by 1 hr 0–999 by 10 hr
Repeatability of the Time Delay at Constant Voltage and Temperature	0.1%	0.1%	0.1%
Reset Time	150 ms	150 ms	150 ms
Operate Time <sup>[8]</sup>	25 ms maximum	25 ms maximum	25 ms maximum
Release Time <sup>[8]</sup>	25 ms maximum	25 ms maximum	25 ms maximum

**Dimensions, in. (mm)**

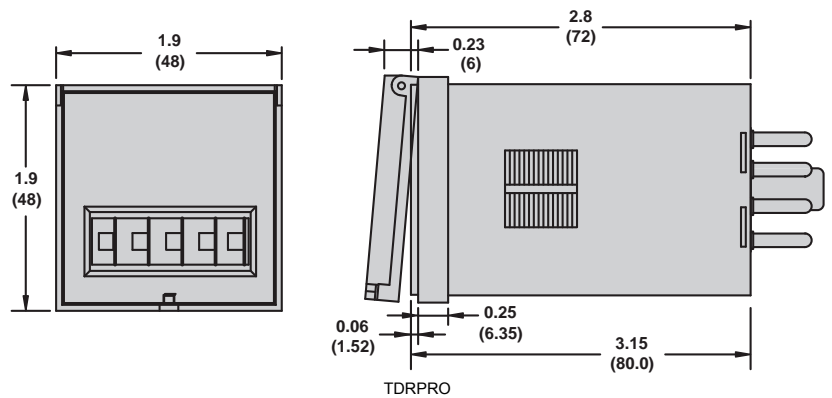

**Wiring Diagrams**

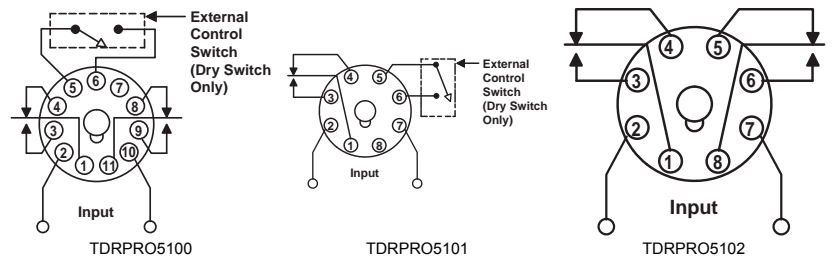

[8] After the time delay period expires, or upon application of the trigger signal (depending on the selected function).

## Relay Accessories

Description	Function	For Use With Relays	Packaging Quantities	Standard Part Number
Socket	Mounting directly to DIN Rail or Panel	TDRPRO5101, TDRPRO5102	10	70750DL81
	Panel Mounting with Screw Terminals and Clamping Plates		10	701691
	DIN or Panel Mounting with Elevator Terminals	TDRPRO5101	10	70750E81
	DIN or Panel Mounting with Screw Terminals and Clamping Plates		10	704641
	Mounting directly to DIN Rail or Panel	TDRPRO5100	10	70750DL111
	DIN or Panel Mounting with Elevator Terminals		10	70750E111
	DIN or Panel Mounting with Screw Terminals and Clamping Plates		10	704651
	Panel Mounting with Screw Terminals and Clamping Plates		10	701701
Metal Retention Clip	Helping secure the relay in the socket	TDRPRO	10	16TDRPROSC

## Socket Accessories

Description	Function	For Use With Sockets	Packaging Quantities	Standard Part Number
Metal DIN Rail, 1 m (39.3 in.)	Quick installation and removal of sockets	Compatible with all sockets listed in the table above.	10	16700DIN
DIN Rail End Clip	Holds sockets firmly in place on the DIN rail		10	16DCLIP1
ID Tags	Identification of circuits in multi-relay applications	70-750E8-1, 70-750EL8-1, 70-750DL8-1, 70-750E11-1, 70-750EL11, 70-750DL11-1	10	16750/782FT1
Insulated Coil Bus Jumper System	Wireless socket connection		10	16750/788CBJ1



9050JCK46V20

### Square D™ JCK General Purpose Plug-In Timers

Square D 9050JCK timing relays are designed to provide low-cost timing in a plug-in housing. The Types JCK11 through 59 provide ±1% repeat accuracy. The Types JCK60 and 70 offer ±0.1% repeat accuracy. These timers are directly interchangeable with many other 8 and 11 pin octal base timers.

- Up to ±0.1% repeat accuracy
- Timing from 0.05 seconds to 999 hours
- Available in 7 timing modes
- DPDT contacts (2 N.O. and 2 N.C.)
- 10 A contact rating
- Transient protected
- Hold down spring available
- Variable or fixed time delay
- Horsepower rated
- RoHS compliant

Table 23.148: Variable Time Delay

Knob Adjustable Timing Range	On Delay <sup>[1]</sup>	Off Delay <sup>[2]</sup> <sup>[1]</sup>	Off Delay Power Trigger <sup>[1]</sup>	Interval <sup>[1]</sup>	One Shot <sup>[2]</sup> <sup>[1]</sup>	One Shot Power Trigger <sup>[1]</sup>	Repeat Cycle <sup>[3]</sup> <sup>[1]</sup>
0.1–10 seconds	JCK11	JCK21	JCK21PT	JCK31	JCK41	JCK41PT	JCK51
0.3–30 seconds	JCK12	JCK22	JCK22PT	JCK32	JCK42	JCK42PT	JCK52
0.6–60 seconds	JCK13	JCK23	JCK23PT	JCK33	JCK43	JCK43PT	JCK53
1.2–120 seconds	JCK14	JCK24	JCK24PT	JCK34	JCK44	JCK44PT	JCK54
1.8–180 seconds	JCK15	JCK25	JCK25PT	JCK35	JCK45	JCK45PT	JCK55
0.1–10 minutes	JCK16	JCK26	JCK26PT	JCK36	JCK46	JCK46PT	JCK56
0.3–30 minutes	JCK17	JCK27	JCK27PT	JCK37	JCK47	JCK47PT	JCK57
0.6–60 minutes	JCK18	JCK28	JCK28PT	JCK38	JCK48	JCK48PT	JCK58
1.2–120 minutes	JCK19	JCK29	JCK29PT	JCK39	JCK49	JCK49PT	JCK59

Table 23.149: Fixed Time Delay

Timing Mode	Type <sup>[1]</sup> <sup>[4]</sup> <sup>[5]</sup>	Timing Range (seconds)
On Delay	JCK1F(XXXX)	0.1 to 180
		181 to 3600
Off Delay <sup>[2]</sup>	JCK2F(XXXX)	0.1 to 180
		181 to 3600
Off Delay with Power Trigger	JCK2F(XXXX)PT	0.1 to 180
		181 to 3600
Interval	JCK3F(XXXX)	0.1 to 180
		181 to 3600
One Shot <sup>[2]</sup>	JCK4F(XXXX)	0.1 to 180
		181 to 3600
One Shot with Power Trigger	JCK4F(XXXX)PT	0.1 to 180
		181 to 3600
Repeat Cycle	JCK5F(XXXX)	0.1 to 180
		181 to 3600

Table 23.150: Voltage Codes

Voltage	Code
12 Vdc	V36
24 Vac/Vdc	V14
48 Vac/Vdc	V17
120 Vac/110 Vdc	V20
240–50/60 Vac	V24

Table 23.151: How to Order

To Order Specify:	Catalog Number		
	Class	Type	Voltage Code
<ul style="list-style-type: none"> <li>• Class Number</li> <li>• Type Number</li> <li>• Voltage Code</li> </ul>	9050	JCK11	V20

[1] Voltage code must be specified to order this product. Refer to the standard voltage codes listed in Table 23.150 and insert as shown in Table 23.151.

[2] Initiating contact can be up to 50 feet from the timer.

[3] Two dials are provided for independently adjustable repeat cycle timing ranges.

[4] (XXXX) denotes the timing period in seconds.

Example: Class 9050 Type JCK1F60 is an On Delay timer fixed at 60 seconds.

[5] Fixed repeat cycle timers can be supplied with the same or different On-Time and Off-Time.

### Type JCK60 and JCK70 Timers

**NOTE:** Type JCK60 and JCK70 Timers are rated for AC supply voltage only. They are not rated for DC coil.

#### Type JCK60

This On-Delay timer uses four push button thumbwheels to set the time delay. One switch is used for the range. The remaining three are used for the time setting.



9050JCK60V14



9050JCK70V14

**Table 23.152: Selection**

Timing Modes	Timing Ranges		Type
On Delay	0.01s	0.05–9.99 seconds	JCK60 <sup>[6]</sup>
	0.1s	00.1–99.9 seconds	
	S	001–999 seconds	
	0.1m	00.1–99.9 minutes	
	M	001–999 minutes	
	0.1h	00.1–99.9 hours	
H	001–999 hours		

#### Type JCK70

This multifunction multirange time delay relay uses five push button thumbwheel switches. Three switches are used for the time delay, one switch is used for the timing range, and the other switch is used to select the timing mode.

**Table 23.153: Selection**

Timing Modes	Timing Ranges	Type
On Delay Interval Off Delay One Shot Repeat Cycle-Off <sup>[7]</sup> Repeat Cycle-On On/Off Delay 1 Shot Falling Edge Watchdog Trigger On Delay	Same as JCK60	JCK70 <sup>[6]</sup>

**Table 23.154: Sockets**

Contact Terminal Arrangement	Connection	For Use with Relays	Sold in Lots of	Catalog Number <sup>[8]</sup>
Mixed <sup>[9]</sup>	Screw Connector	JCK11–19 JCK31–39 JCK51–59 JCK60 JCK1 F JCK3 F JCK5 F	1	8501NR51
		JCK21–29 JCK41–49 JCK70 JCK2F JCK4F	10	8501NR51B
		JCK21–29 JCK41–49 JCK70 JCK2F JCK4F	1	8501NR61
		JCK21–29 JCK41–49 JCK70 JCK2F JCK4F	10	8501NR61B
Separate <sup>[10]</sup>	Screw Connector	JCK11–19 JCK31–39 JCK51–59 JCK60 JCK1 F JCK3 F JCK5 F	1	8501NR52
		JCK21–29 JCK41–49 JCK70 JCK2F JCK4F	10	8501NR52B
		JCK21–29 JCK41–49 JCK70 JCK2F JCK4F	1	8501NR62
		JCK21–29 JCK41–49 JCK70 JCK2F JCK4F	10	8501NR62B



8501NR61



8501NR52

**Table 23.155: Accessories (sold in lots of 10)**

Description	For Use With	Sold in Lots of	Catalog Number
Metal Restraining Strap	8501NR51 sockets	1	8501NH7
	8501NR52 sockets		
	8501NR61 sockets		
	8501NR62 sockets		



8501NH7

#### Approvals for 9050JCK Timers



File: E3190  
CCN: NLDX2



File: E3190  
CCN:  
NLDX,  
NLDX7<sup>[11]</sup>



File:  
260367  
Class:  
3211 07



RoHS  
Compliant

<sup>[6]</sup> Voltage code must be specified to order this product. Refer to the standard voltage codes listed in Table 23.150 and insert as shown in Table 23.151.

<sup>[7]</sup> The repeat cycle mode uses the same on-time and off-time.

<sup>[8]</sup> Please note that the B suffix only designates quantities of 10 and is not printed on the socket.

<sup>[9]</sup> The inputs and outputs are mixed on both sides.

<sup>[10]</sup> The inputs and outputs are on separate sides.

<sup>[11]</sup> When used with the appropriate 8501NR socket.

**Zelio™ Current Measurement Relays**

Zelio Current Measurement Relays are designed to measure under and overcurrent conditions, without external sensors. Current measurement relays enable continuous monitoring of the operation of electrical and mechanical loads such as motors and heaters. They are DIN rail mountable and the control status is indicated by an LED.

**RM17JC Current Control Relay**

- Monitors AC currents
- Designed to monitor overcurrent
- Equipped with an integrated current transformer

**RM35JA Current Control Relays**

- Selection between overcurrent or undercurrent
- Automatic DC or AC recognition
- Selectable memory function



RM17JC00MW



RM35JA31MW



RM35JA32MW

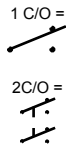

**Table 23.156: Zelio Current Measurement Relays**

Supply Voltage	Measurement Range		Output 5 A	Width		Catalog Number
	Range <sup>[1]</sup>	Terminals		Inches	mm	
24–240 Vac/dc	2–20 A	N/A	1 C/O	0.69	17.50	RM17JC00MW
	2–20 mA	E1-M	2 C/O	1.38	35.00	RM35JA31MW
	10–100 mA	E2-M				
	50–500 mA	E3-M				
	0.15–1.5 A	E1-M				
	0.5–5 A	E2-M				
1.5–15 A	E3-M	RM35JA32MW				

**Table 23.157: Output Characteristics and Measurement Circuit Characteristics**

Type of Relay	RM17JC00MW	RM35JA31MW	RM35JA32MW
Setting accuracy	Plus or minus 10% of the full scale value		
Repeat accuracy (with constant parameters)	Plus or minus 0.5%		
Hysteresis	15% of the threshold setting, fixed	5 to 50% of the threshold setting, adjustable	
Time delay accuracy (with constant parameters)	N/A	Plus or minus 2%	
Time delay on pick-up	500 ms	300 ms	
Conforming to standards	NF EN 60255-6		
Ambient air temperature around the device	Storage	-40 to 158 degrees F (-40 to +70°C)	
	Operational	-4 to 122 degrees F (-20 to +50°C)	

**Approvals for Zelio Current Measurement Relays**



File: E173076  
CNN: NRNT,  
NRNT7



File: 248382  
Class: 3211 07



CE: 73/23/EEC  
and EMC 89/  
336/EEC

GL, C-Tick,  
GOST, RoHS

**Approximate Dimensions**

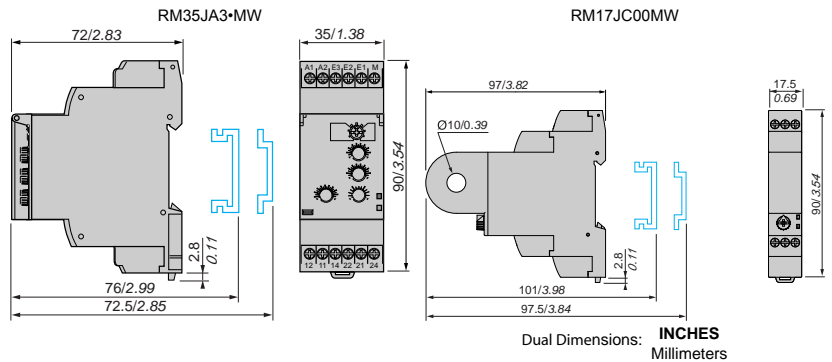

[1] Above 15 A, a current transformer can be connected (for RM35JA3-MW). See page 57 of catalog 8430CT0601 for suggested wiring.

**Zelio™ Phase Measurement Relays**

Zelio Phase Measurement Relays monitor their own power supply. Relay status is indicated by an LED and they are DIN rail mountable.

RM17TG-0 measurement and control relays are for monitoring of 3-phase supplies for the correct sequencing of phases L1, L2, and L3, as well as the total loss of one or more phases.



RM17TG-0



RM17TE00



RM17TA00



RM35TM-MW



RM35TF30

**Table 23.158: 3-Phase Supply Control Relays**

Supply Voltage	Detection Threshold	Output 5 A	Width		Catalog Number
			inches	mm	
208-480 Vac	<100 Vac	1 C/O	0.69	17.50	RM17TG00
208-440 Vac		2 C/O			RM17TG20

**Table 23.159: Multifunction 3-Phase Supply Control Relays**

Supply Voltage	Voltage Range	Output 5 A	Width		Catalog Number
			inch	mm	
208-480 Vac	Selectable voltages: 208, 220, 380, 400, 415, 440, 480	1 C/O	0.69	17.50	RM17TT00
					RM17TA00
					RM17TU00
					RM17TE00

**Table 23.160: RM17TT, RM17TA, RM17TU, and RM17TE Multifunction Control Relays monitor the following on 3-phase supplies:**

Function	RM17TT	RM17TA	RM17TU	RM17TE
Sequence of phases L1, L2 and L3	Yes	Yes	Yes	Yes
Phase failure with regeneration (0.7 x selected voltage range)	Yes	Yes	Yes	Yes
Asymmetry (phase imbalance)	No	Yes	No	Yes
Undervoltage	No	No	Yes	No
Overvoltage and undervoltage	No	No	No	Yes

**Table 23.161: 3-Phase Supply and Motor Temperature Control Relays**

Supply Voltage	Measurement Range	Output 5 A	Width		Catalog Number
			inch	mm	
220-480 Vac	208-480 Vac	2 N.O.	1.38	35.00	RM35TM50MW
					RM35TM250MW

**Table 23.162: RM35TM Control Relays monitor the following on 3-phase supplies:**

Function	RM35TM50MW	RM35TM250MW
Sequence of phases L1, L2 and L3	Yes	Yes
Phase failure	Yes	Yes
Motor temperature via PTC probe	Yes	Yes
Selection (with or without memory)	No	Yes
Test-reset button	No	Yes

RM35TF30 measurement and control relay is for monitoring of phase sequence, phase failure, asymmetry, undervoltage and overvoltage in window mode.

**Table 23.163: Multifunction 3-Phase Supply Control Relays**

Supply Voltage	Measurement Range	Output 5 A	Width		Catalog Number
			inch	mm	
220-480 Vac	194-528 Vac	2 C/O	1.38	35.00	RM35TF30

**Approvals for Zelio Phase Measurement Relays**



File: E173076  
CNN: NRNT,  
NRNT7



File: 248382  
Class: 3211 07



CE: 73/23/EEC  
and EMC 89/  
336/EEC

GL, C-Tick,  
GOST, RoHS

**Approximate Dimensions**

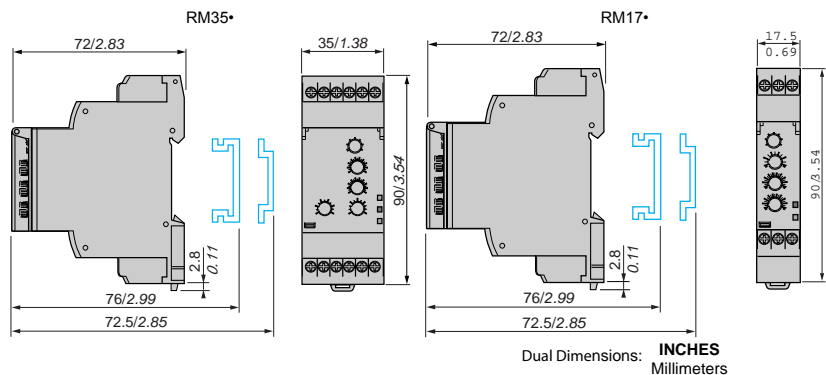
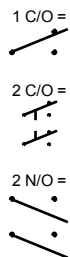

**Zelio™ Voltage Measurement Relays**

Zelio Voltage Measurement Relays are DIN rail mountable and relay status is indicated by an LED. Single phase and DC voltage measurement and control relays RM17UAS•• and RM17UBE•• monitor:

- Overvoltage
- Undervoltage
- Overvoltage and undervoltage
- Nominal voltages



**Table 23.164: Single-phase and DC voltage control relays**

Supply Voltage	Ranges Controlled	Output 5 A	Width		Catalog Number
			in.	mm	
12 Vdc	9–15 Vdc	1 C/O	0.69	17.50	RM17UAS14[2]
24–48 Vac/Vdc	20–80 Vac/Vdc				RM17UAS16[2]
110–240 Vac/Vdc	65–260 Vac/Vdc				RM17UAS15[2]
24–48 Vac/Vdc	20–80 Vac/Vdc				RM17UBE16[3]
110–240 Vac/Vdc	65–260 Vac/Vdc				RM17UBE15[3]

Multifunction voltage control relays RM35UA1•MW monitor both AC and DC voltages.

- Automatic Vdc or Vac recognition
- Selection between overvoltage and undervoltage

**Table 23.165: Multifunction voltage control relays**

Supply Voltage	Measurement Range		Output 5 A	Width		Catalog Number
	Range[4]	Terminals		in.	mm	
24–240 Vac/Vdc	0.05–0.5 V	E1-M	2 C/O	1.38	35.00	RM35UA11MW
	0.3–3 V	E2-M				
	0.5–5 V	E3-M				
	1–10 V	E1-M				RM35UA12MW
	5–50 V	E2-M				
	10–100 V	E3-M				
	15–150 V	E1-M				
	30–300 V	E2-M				
	60–600 V	E3-M				

3-phase voltage control relays monitor:

- Failure of one or more phases
- Voltage between phases
- Absence of neutral
- Voltage between phases and neutral
- Overvoltage and undervoltage

**Table 23.166: Three-phase voltage control relays**

Rated 3-Phase Supply Voltage Vac	Measurement Range	Output 5 A	Width		Catalog Number
			in.	mm	
220–480 phase-phase	195–528 Vac	1 C/O + 1 C/O 1 per threshold	1.38	35.00	RM35UB330[5]
120–277 phase-neutral	183–528 Vac	1 C/O	0.69	17.50	RM17UB310[5]
120–277 phase-neutral	114–329 Vac	1 C/O + 1 C/O 1 per threshold	1.38	35.00	RM35UB3N30[4]

**Approvals for Zelio Voltage Measurement Relays**

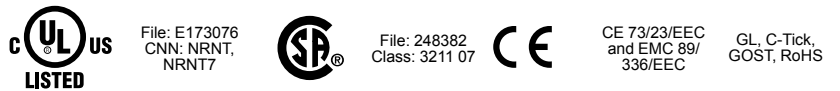

**Approximate Dimensions**

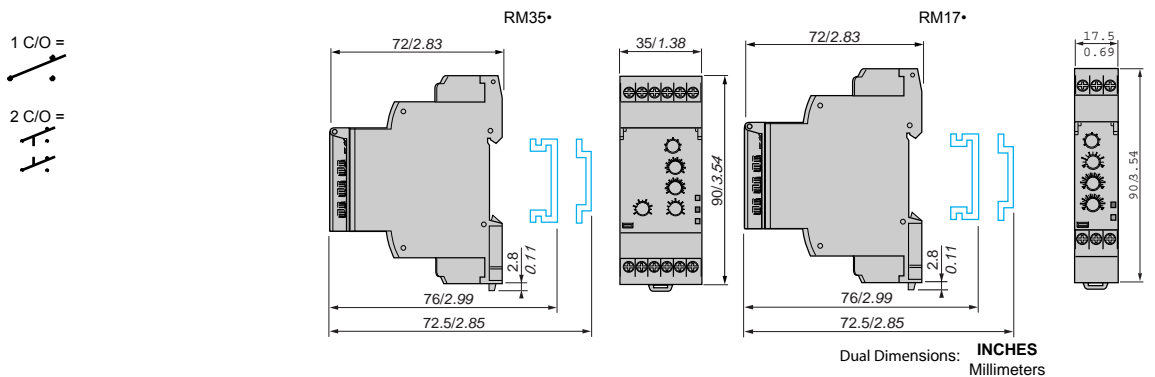

[2] Provides overvoltage or undervoltage protection.  
 [3] Provides overvoltage and undervoltage protection in window mode.  
 [4] Provides overvoltage and undervoltage protection between phases and neutral and absence of neutral.  
 [5] Provides overvoltage and undervoltage protection between phases.



RM35LM33MW



RM35LV14MW

### Zelio™ Level Control Relays and Zelio™ Pump Control Relays

Zelio level control relays control one or two levels with fill or empty function. The settings are protected by a sealable cover, control status is indicated by an LED, and they are DIN rail mountable. RM35LM is designed to control levels of conductive liquid, and RM35LV is designed to control levels of other materials.

#### Application examples for RM35LM:

- Detecting pump seal failures
- Spring, town, industrial and sea water
- Metallic salt, acid or base solutions
- Liquid fertilizers
- Non-concentrated alcohol (<40%)

#### Application examples for RM35LV:

- Liquids in the food-processing industry: milk, beer, coffee, etc.
- Chemically pure water
- Fuels, liquid gasses (inflammable)
- Oil, concentrated alcohol (>40%)
- Ethylene, glycol, paraffin, varnish and paints

**Table 23.167: Level Control Relays**

Time Delay on Crossing the Threshold	Function	Output Relay	Supply Voltage 50/60 Hz	Measurement Ranges	Catalog Number
0.1–5 seconds, 0 + 10%	Detection by resistive probes	2 C/O, 5 A	24–240 Vac/Vdc	250–5 k	RM35LM33MW
				5 k–100 k	
	Detection by discrete sensors	1 C/O, 5 A		50 k–1 M	RM35LV14MW
				—	

**Table 23.168: Probes**

Application	No. of probes	Operating temperature		Max. Pressure kg/cm <sup>2</sup>	Catalog Number
		°F	°C		
Recommended for drink vending machines and where installation space is limited (stainless steel) <sup>[6]</sup>	3	176	80	2	RM79696044
Suitable for boilers, pressure vessels, and under high temperature conditions (1) (304 stainless steel) <sup>[6]</sup>	1	392	25	200	RM79696014

**Table 23.169: Probes**

Description	Catalog Number
Protected probe for mounting by suspension, protective shell PUC (S7) Electrode: stainless steel	RM79696043
Liquid level control probe, suspended by cable, maximum operating temperature 212 °F (100 °C) <sup>[7]</sup>	LA9RM201

**Table 23.170: Electrode Holders**

Description	Material	Catalog Number
Electrode for use up to 662°F (350°C)	Stainless steel isolated by ceramic	RM79696006



RM79696043



LA9RM201



RM79696006



[6] 3/8 in. BSP mounting thread with hexagonal head. Use a 24 mm spanner for tightening.

[7] 3/8 in. BSP mounting head.

Refer to Catalog [DIA5ED2160501EN](#)

**Pump Control Relay**

Zelio pump control relay RM35BA10 can operate on a single-phase or 3-phase supply. It incorporates three functions in a signal unit:

- Over and under current measurement
- Phase presence control
- Single or three phase

It has two operating modes which are designed to control a pump via two external signal inputs (Y1 Y2). These two signals are controlled by volt-free contacts. Control inputs Y1 and Y2 can be connected to:

- Level sensor
- Level relay
- Pressure sensor
- Push button



RM35BA10

1 C/O =



2 C/O =



**Table 23.171: Pump Control Relay**

Description	Current Range Controlled	Supply Voltage	Output	Catalog Number
Pump Control Relay	1–10 A	208–480 Vac, 3 phase	1 C/O 5 A	RM35BA10
		230, single-phase		

**Approvals for Zelio Level Control and Pump Control Relays**



File: E173076  
CNN: NRNT,  
NRNT7



File: 248382  
Class: 3211 07



CE 73/23/EEC  
and EMC 89/  
336/EEC

GL, C-Tick,  
GOST, RoHS

**Approximate Dimensions (mm/in.)**

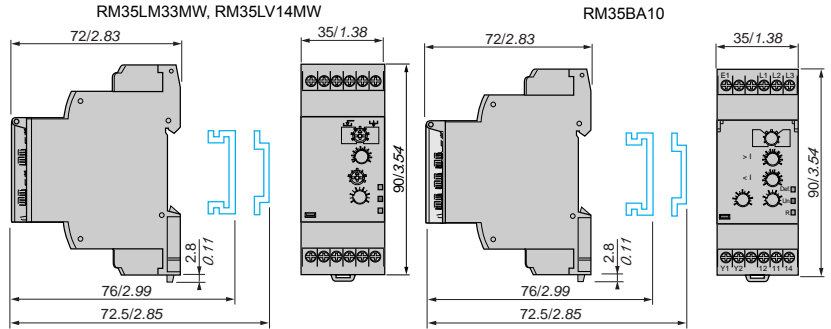

Refer to Catalog DIA5ED2160501EN

Zelio™ Speed, Frequency, & Temp. Control Relays

Zelio speed control relay RM35SOMW monitors underspeed and overspeed conditions, with or without memory, with inhibition by an external contact. It operates with either N.O. or N.C. sensors. Adjustable time between impulses is 0.05 s to 10 min. Power-on inhibition time is adjustable from 0.6 to 60 s. Inhibition is controlled by an external contact. Settings are protected by a sealable cover, control status is indicated by an LED, and it is DIN rail mountable.

Table 23.172: Speed Control Relay

Function	Time Delay	Measurement Input	Supply	Out-put	Catalog Number
Under-speed	0.05 s to 10 min	3-wire PNP or NPN proximity sensor	24–240 Vac/ Vdc	1 C/O 5 A	RM35S0MW
Over-speed		Namur type proximity sensor 0–30 V voltage Volt-free contact			

Zelio frequency control relay RM35HZ monitors its own supply voltage. Settings are protected by a sealable cover, control status is indicated by an LED, and it is DIN rail mountable.

Table 23.173: Frequency Control Relay

Function	Controlled	Supply Voltage	Output	Catalog Number
Over frequency and under frequency (50 or 60 Hz)	40–60 Hz (50 Hz) / 50–70 Hz (60 Hz)	120–277 Vac	1 C/O + 1 C/O 5 A	RM35HZ21FM

Zelio temperature control relays are designed for monitoring the temperature in elevator (lift) rooms, in compliance with directive EN81. For use with PT100 input (customer supplied). Features adjustable control, control status indicated by an LED, and is DIN rail mountable.

Table 23.174: Temperature Control Relays

Function	Supply Voltage	Vac	Output	Catalog Number	
Over temperature 93 to 114°F (34 to 46°C)	24–240 Vac/Vdc	—	1 C/O 5 A	RM35ATL0MW	
Under temperature 30 to 51°F (-1 to 11°C)		—	2 N.O. 5 A	RM35ATR5MW	
Over temperature 93 to 114 °F (34 to 46°C)		208–480 Vac		2 N.O. 5 A	RM35ATW5MW
Under temperature 30 to 51°F (-1 to 11°C)					
Phase sequence					
Phase failure					

Approvals for Zelio Speed, Frequency, and Temperature Control Relays



File: E173076  
CNN: NRNT,  
NRNT7



File: 248382  
Class: 3211 07



CE: 73/23/EEC  
and EMC 89/  
336/EEC

GL, C-Tick,  
GOST, RoHS

Approximate Dimensions (mm/in.)

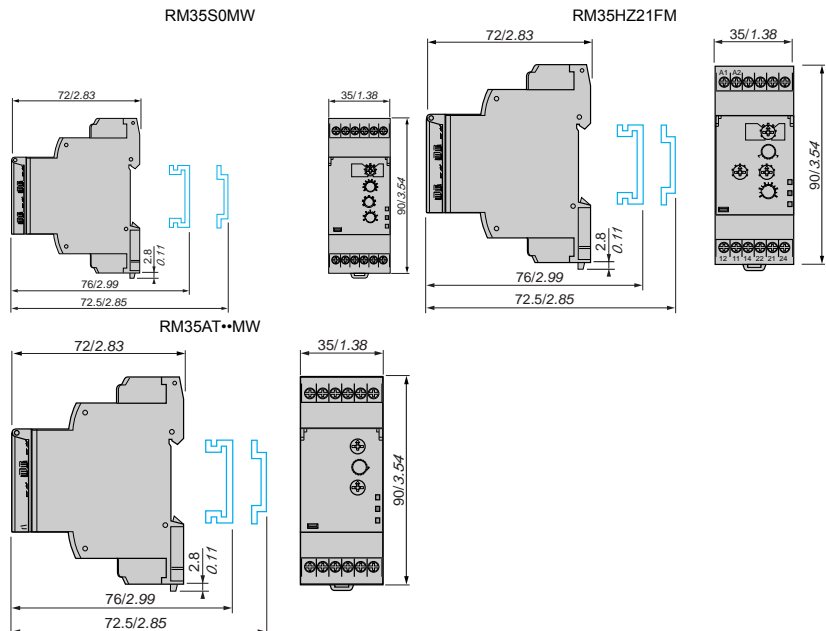
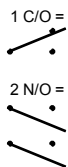

RM35S0MW



RM35HZ21FM



RM35AT-0MW



ABL8MEM12020

ABL8REM24030

### Phaseo™ DC Power Supply

Phaseo switch mode power supplies are totally electronic and their output voltage is regulated. They offer:

- Compact size
- High degree of output voltage stability

For use with Universal power supplies, see optional function modules in catalog DIA3ED207041EN-US, which offer a set of solutions to meet the needs for continuity of service such as:

- Immunity to microbreaks
- Voltage holding during power outages
- Voltage holding during power supply equipment failure

#### Table 23.175: Modular, Single Phase

Meets all the needs of simple automation systems with power ratings from 7 to 60 W and an output voltage of 5 Vdc, 12 Vdc, or 24 Vdc.

Input Voltage (Vac)	Output Voltage (Vdc)	Nominal Current (I)	Protection Reset	Catalog Number
100–240	5	4	Auto	ABL8MEM05040
	12	2		ABL8MEM12020
	24	0.3		ABL8MEM24003
		0.6		ABL8MEM24006
		1.2		ABL8MEM24012
		2.5		ABL7RM24025

#### Table 23.176: Optimum, Single Phase

The low-cost solution for applications supplied at 12 Vdc, 24 Vdc, or 48 Vdc and requiring currents between 3 and 5 A.

Input Voltage (Vac)	Output Voltage (Vdc)	Nominal Current (I)	Protection Reset	Catalog Number
100–240	12	5	Auto	ABL7RP1205
	24	3		ABL8REM24030
		5		ABL8REM24050
		2.5		ABL7RP4803

#### Table 23.177: Universal, Single Phase

Adapts to the majority of power distribution systems with power ratings from 72 to 480 W at 24 Vdc. The same power supply can be connected phase-to-neutral (N-L1) or phase-to-phase (L1-L2) for line supplies ranging from 100 to 500 Vac. Energy reserve, diagnostics, and choice of manual or auto reset are integrated into these units.

Input Voltage (Vac)	Output Voltage (Vdc)	Nominal Current (I)	Auto-Protection Reset	Catalog Number
100–120 / 200–500	24	3	Auto/Manual	ABL8RPS24030
		5		ABL8RPS24050
		10		ABL8RPS24100
100–120 / 200–240	24	20	Auto/Manual	ABL8RPM24200

#### Table 23.178: Universal, Three Phase

This three-phase, 480 to 960 W, 24 Vdc output offering is particularly suited for complex machines and processes. Energy reserve, diagnostics, and choice of manual or auto reset are integrated into these units.

Input Voltage (Vac)	Output Voltage (Vdc)	Nominal Current (I)	Auto-Protection Reset	Catalog Number
380–500	24	20	Auto/Manual	ABL8WPS24200
		40		ABL8WPS24400

#### Table 23.179: Dedicated, Single Phase

Designed for integration into repetitive equipment with power ratings from 60 to 240 W and an output voltage of 12 Vdc or 24 Vdc.

Input Voltage (Vac)	Output Voltage (Vdc)	Nominal Current (I)	Protection Reset	Catalog Number
100–240 <sup>[1]</sup>	12	5	Auto	ABL1REM12050
	24	2.5		ABL1REM24025
		4.2		ABL1REM24042
100–120 / 200–240 <sup>[2]</sup>	24	6.2	Auto	ABL1REM24062
		10		ABL1REM24100
100–240 <sup>[1]</sup>	12	8.3	Auto	ABL1RPM12083
	24	4.2		ABL1RPM24042
100–120 / 200–240 <sup>[2]</sup>	24	6.2	Auto	ABL1RPM24062
		10		ABL1RPM24100

#### Approvals for Phaseo DC Power Supply

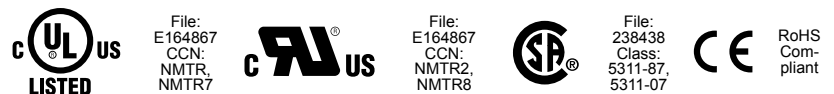

- SEMI F47 Compliant for most units
- For additional information, refer to Catalog DIA3ED207041EN-US.

[1] Compatible input voltage 120-370 Vdc not indicated on the product.  
[2] Compatible input voltage 180-370 Vdc not indicated on the product.

**Zelio™ Analog Interface Modules**

The Zelio Analog range of converters is designed to convert signals emitted by sensors or electrical measurement devices into standard electrical signals that are compatible with automation platforms and controllers. They also allow the connection distance between a sensor and a measurement device to be increased, for example, between a thermocouple and a programmable controller



RMTJ40BD



RMTK90BD



RMPT70BD



RMPT13BD



RMCN22BD

**Table 23.180: Converters for Type J and K thermocouples—supply voltage 24 Vdc ± 20%, non-isolated**

Type	Temperature Range		Switchable Output Signals	Catalog Number
	°F	°C		
Type J	32–302	0–150	0–10 V, 0–20 mA, 4–20 mA	RMTJ40BD
	32–572	0–300		RMTJ60BD
	32–1112	0–600		RMTJ80BD
Type K	32–1112	0–600	0–10 V, 0–20 mA, 4–20 mA	RMTK80BD
	32–2192	0–1200		RMTK90BD

**Table 23.181: Converters for Universal Pt100 probes—supply voltage 24 Vdc ± 20%, non-isolated**

Type	Temperature Range		Switchable Output Signals	Catalog Number
	°F	°C		
Pt100 2-wire, 3-wire, and 4-wire	- 40–104	- 40–40	0–10 V, 0–20 mA, 4–20 mA	RMPT10BD
	- 148–212	- 100–100		RMPT20BD
	32–212	0–100		RMPT30BD
	32–482	0–250		RMPT50BD
	32–932	0–500		RMPT70BD

**Table 23.182: Converters for Optimum Pt100 probes<sup>[1]</sup>—supply voltage 24 Vdc ± 20%, non-isolated**

Type	Temperature Range		Switchable Output Signals	Catalog Number
	°F	°C		
Pt100 2-wire, 3-wire, and 4-wire	- 40–104	- 40–40	0–10 V or 4–20 mA	RMPT13BD
	- 148–212	- 100–100		RMPT23BD
	32–212	0–100		RMPT33BD
	32–482	0–250		RMPT53BD
	32–932	0–500		RMPT73BD

**Table 23.183: Universal Voltage/Current Converters**

Type	Input Signal	Output Signal	Catalog Number
Supply voltage 24 Vdc ± 20%, non-isolated	0–10 V or 4–20 mA	0–10 V or 4–20 mA	RMCN22BD
Supply voltage 24 Vdc ± 20%, isolated	0–10 V, ± 10 V, 0–20 mA, 4–20 mA	Switchable: 0–10 V, ± 10 V, 0–20 mA, 4–20 mA	RMCL55BD
	0–50 V, 0–300 V, 0–500 V DC or AC, 50/60 Hz	Switchable: 0–10 V, 0–20 mA, 4–20 mA	RMCV60BD
	0–1.5 A, 0–5 A, 0–15 A DC or AC, 50/60 Hz	0–10 V, 0–20 mA, 4–20 mA	RMCA61BD

**Approvals for Zelio Analog Interface Modules**



File: E164353  
CCN: NKCR



File: 044087\_S\_000  
Class: 32T1 07



IEC  
60947-1

RoHS  
Compliant

**Table 23.184: How to Order**

To Order Specify:	Catalog Number
• Catalog Number	RMCN22BD

[1] Converters dedicated to Zelio Logic smart relays.



ABS2EA02EM



ABS2SA01MB

### Solid State Interface Modules

ABS solid state relay interface modules are for discrete digital input or output control signals exchanged in automated equipment. Features include:

- High operating rate
- 5 separate character places for marking
- Silent operation
- LED indication of the control signal state
- 35 mm DIN 3 or 32 mm DIN 1 track mountable

**Table 23.185: Solid State Interface Input Modules**

Input Module Catalog No.	Input Module Catalog Number				
	ABS2EC01EA	ABS2EC01EB	ABS2EC01EE	ABS2EA02EF	ABS2EA02EM
Dimensions (WxDxH)[2]	Inches: 0.37 x 2.78 x 2.91			mm: 9.5 x 70.5 x 74	
<b>Control Circuit Characteristics</b>					
Rated Voltage US	5 Vdc	24 Vdc	48 Vdc	120/127 60Hz	230/240 60Hz
Maximum Voltage	6 (TTL)	28.8 Vdc	57.6 Vdc	140 Vac	264 Vac
Maximum Current at Us	13.6 mA	12 mA	10.5 mA	17 mA	15 mA
Internal Protection Against Reverse Polarity	Yes	Yes	Yes	N/A	N/A
<b>Output Circuit Characteristics</b>					
Rated Operational Voltage Ve	5 to 48 Vdc	5 to 48 Vdc	5 to 48 Vdc	5 to 48 Vdc	5 to 48 Vdc
Min./Max. Voltage	2/60 Vdc	2/60 Vdc	2/60 Vdc	2/60 Vdc	2/60 Vdc
Min./Max. Switching Current	1/50 mA	1/50 mA	1/50 mA	1/50 mA	1/50 mA
Rated Insulation Voltage	Conforming to IEC 60947-1: 300 V Conforming to IEC 0110: 250 V group C				
Approvals	UL E164353, CSA 044087_S_000, IEC 60947-1				

**Table 23.186: Solid State Interface Output Modules**

	Output Module Catalog Number			
	ABS2SC01EB	ABS2SC02EB	ABS2SA01MB	ABS2SA02MB
Dimensions (W x D x H) [2]	Inches: 0.69 x 2.78 x 2.91		mm: 17.5 x 70.5 x 74	
<b>Control Circuit Characteristics</b>				
Rated Voltage Us	24 Vdc	24 Vdc	24 Vdc	24 Vdc
Maximum Voltage	28.8 Vdc	28.8 Vdc	28.8 Vdc	28.8 Vdc
Maximum Current at Us	12 mA	12 mA	13.6 mA	13.6 mA
Internal Protection against reverse polarity	Yes	Yes	Yes	Yes
<b>Output Circuit Characteristics</b>				
Rated Operational Voltage Ve	5 to 48 Vdc	5 to 48 Vdc	24 to 240 Vac	24 to 240 Vac
Maximum Voltage	57.6 Vdc	57.6 Vdc	264 Vac	264 Vac
Internal Protection against reverse polarity	Yes	Yes	Yes	Yes
External Protection	3.15 A external fuse fast blow (Ik <= 1 kA AC and Ik <= 100 A DC)			
Rated insulation voltage	Conforming to IEC 60947-1: 300 V Conforming to VDE 0110: 250 V group C			
Approvals	UL E164353, CSA 044087_S_000, IEC 60947-1			

- For Mounting Track, see [Mounting Track, End Clamps, Jumpers, Fanning Strips, page](#) .

**Table 23.187: How to Order**

To Order Specify:	Catalog Number
• Catalog Number	ABS2EC01EA

[2] Dimensions mounted on DIN 3 (7.5 mm high) track.

Refer to Catalog DIA3ED2090304EN-US

**Electromechanical Interface Modules**

ABR electromechanical relay modules are for discrete digital input or output control signals exchanged in automated equipment. Features include:

- High contact reliability
- LED indication of the control signal state
- 5 separate character places for marking
- 35 mm DIN 3 or 32 mm DIN 1 track mountable

**Table 23.188: Input Modules**

Coil Voltage	Options	1 N.O. Contact	1 C.O. Contact	2 N.O. Contacts
		Catalog Number	Catalog Number	Catalog Number
24 Vac/Vdc	Manual Operator and LED Indication	ABR1E118B <sup>[3]</sup>	ABR1E318B <sup>[3]</sup>	ABR1E418B <sup>[3]</sup>
48 Vac/Vdc		ABR1E118E <sup>[3]</sup>	ABR1E318E <sup>[3]</sup>	ABR1E418E <sup>[3]</sup>
110–125 Vdc		ABR1E112F <sup>[3]</sup>	ABR1E312F <sup>[3]</sup>	ABR1E412F <sup>[3]</sup>
110–127 Vac 50/60 Hz		ABR1E111F <sup>[3]</sup>	ABR1E311F <sup>[3]</sup>	ABR1E411F <sup>[3]</sup>
230–240 Vac 50/60 Hz		ABR1E111M <sup>[3]</sup>	ABR1E311M <sup>[3]</sup>	ABR1E411M <sup>[3]</sup>
230–240 Vac 50/60 Hz	Manual Operator	ABR1E101M <sup>[3]</sup>	ABR1E301M <sup>[3]</sup>	—
24 Vdc	LED Indication	ABR2E112B	—	—
48 Vdc		ABR2E112E	—	—
120–127 Vac 60 Hz		ABR2E116F	—	—
230–240 Vac 50/60 Hz		ABR2E111M	—	—
24 Vdc		—	ABR2EB312B	—

**Table 23.189: Output Modules**

Coil Voltage	Options	1 N.O. Contact	1 C.O. Contact	2 N.O. Contacts	1 N.C. & 1 N.O. Contact
		Catalog Number	Catalog Number	Catalog Number	Catalog Number
24 Vdc	Manual Operator	ABR1S102B <sup>[3]</sup>	ABR1S302B <sup>[3]</sup>	ABR1S402B <sup>[3]</sup>	ABR1S602B <sup>[3]</sup>
24 Vac/Vdc	Manual Operator and LED Indication	ABR1S118B <sup>[3]</sup>	ABR1S318B <sup>[3]</sup>	ABR1S418B <sup>[3]</sup>	ABR1S618B <sup>[3]</sup>
48 Vac/Vdc		ABR1S118E <sup>[3]</sup>	ABR1S318E <sup>[3]</sup>	ABR1S418E <sup>[3]</sup>	ABR1S618E <sup>[3]</sup>
110–127 Vac 50/60 Hz		ABR1S111F <sup>[3]</sup>	ABR1S311F <sup>[3]</sup>	ABR1S411F <sup>[3]</sup>	ABR1S611F <sup>[3]</sup>
24 Vdc	LED Indication	ABR2S112B	—	—	—
48 Vdc		—	ABR2SB312B	—	—
24 Vdc		—	ABR2S102B	—	—

**Table 23.190: Coil Data: ABR1E, ABR2E**

Relay		ABR1E				ABR2E				
		24 Vac/Vdc	48 Vac/Vdc	127 Vdc	127 Vac	240 Vac	24 Vdc	48 Vdc	127 Vac	240 Vac
Coil Voltage U <sub>e</sub>	V	24	48	127	127	240	24	48	127	240
Maximum Voltage	V	30	53	137	140	255	28.8	56	140	264
Pick-up Voltage	V	17	38	97	93	195	16.9	37.3	97	186
Minimum Sealed Current	mA	5.2	5.4	1.5	2.4	2	2	2	2.5	2.5
Maximum Sealed Current	mA	62	36	15	8	7	19.5	11	16	15

**Table 23.191: Coil Data: ABR2EB, ABR1S, ABR2S, ABR2SB**

Relay		ABR2EB	ABR1S			ABR2S	ABR2SB
		24 Vdc	24 Vdc	48 Vac/Vdc	127 Vac	24	24
Coil Voltage U <sub>e</sub>	V	24 Vdc	24 Vdc	48 Vac/Vdc	127 Vac	24	24
Maximum Voltage	V	28.8	30	53	140	28.8	28.8
Pick-up Voltage	V	16.9	17	38	83	16.9	16.9
Minimum Sealed Current	mA	2	6.6	6.2	5.4	2	2
Maximum Sealed Current	mA	29	62	62	36	8	29

**Table 23.192: Contact Ratings**

Relay		ABR1E	ABR2E	ABR2EB	ABR1S	ABR2S	ABR2SB
Rated Voltage U <sub>e</sub>	Vac	250	115	48	250	230	48
Rated Voltage U <sub>e</sub>	Vdc	125	100	48	125	120	48
Thermal Current I <sub>th</sub>	A	2	1	0.05	5	5	0.05
Break Rating (AC14)	A	1	0.5	1	1	1	—
Break Rating (DC13)	A	1	1	1	1	1.5	—

**Table 23.193: Dimensions**

Modules	Approximate Dimensions (WxDxH) <sup>[4]</sup>	
	In.	mm
ABR1E, ABR2EB, ABR2SB	0.69 x 2.91 x 2.78	17.5 x 74 x 70.5
ABR2E	0.37 x 2.91 x 2.78	9.5 x 74 x 70.5
ABR2S1	0.47 x 2.91 x 2.78	12 x 74 x 70.5

Approvals	
ABR1E, ABR2E	UL E164353, CSA 044087_S_000, IEC 60947-1
ABR1S, ABR2S	UL E164353, CSA 044087_S_000, IEC 60947-1

- ABR1 relays are RoHS compliant.
- For Mounting Track, see [page](#) .

[3] RoHS Compliant

[4] Dimensions mounted on DIN 3 (7.5 mm high) track.



ABR1E411F



ABR2E112E



ABR1S111F



ABR2S102B