



Main

Range of Product	Harmony STO & STU
Product or Component Type	Touch panel screen
Software Designation	Vijeo Designer
Operating System	Harmony
Processor name	CPU ARM9

Complementary

Display size	5.7 inch
Display Type	QVGA TFT colour touchscreen
Display colour	65536 colours
Display Resolution	320 x 240 pixels QVGA
Touch panel	Analogue
Backlight lifespan	50000 hours
Brightness	16 levels
Character font	Taiwanese (traditional Chinese) Japanese (ANK, Kanji) Chinese (simplified Chinese) ASCII Korean
[Us] rated supply voltage	24 V DC
Supply	External source
Supply voltage limits	20.4...28.8 V
Inrush current	30 A
Power consumption in W	6.8 W
Number of pages	Limited by internal memory capacity
Processor frequency	333 MHz
Memory description	Application memory 16 MB Back up of data 64 kB
Integrated connection type	1 USB 2.0 type mini B 1 USB 2.0 type A COM1 serial link - female RJ45 - RS232C/RS485 <= 115.2 kbits/s) Power supply - removable screw terminal block 1 Ethernet - RJ45
Realtime clock	Access to the PLC real-time clock
Downloadable protocols	Uni-TE Modbus TCP/IP Third party protocols Modbus
Fixing mode	Ø 22 mm hole
Enclosure Material	PC/PBT and PAA
Marking	With Schneider logo CE
Height	5.08 in (129.15 mm)
Width	6.42 in (163 mm)
Depth	2.22 in (56.5 mm)

Environment

Immunity to microbreaks	7 ms
Standards	UL 1604 FCC Class A IEC 61000-6-2 EN 61131-2 UL 508
Product Certifications	UL class 1 Div2 T4A ou T5 C-tick CULus Marine
Ambient Air Temperature for Operation	32...122 °F (0...50 °C)
Ambient Air Temperature for Storage	-4...140 °F (-20...60 °C)
Relative humidity	0...85 % without condensation
Operating altitude	<= 6561.68 ft (2000 m)
IP degree of protection	IP20 IEC 60529 rear panel) IP65 IEC 60529 front panel)
NEMA degree of protection	NEMA 4X front panel indoor use)
Shock resistance	15 gn 11 ms IEC 60068-2-27
Vibration resistance	+/- 3.5 mm 5...9 Hz) IEC 60068-2-6 1 gn 9...150 Hz) IEC 60068-2-6
Resistance to electromagnetic fields	9.14 V/m (10 V/m) IEC 61000-4-3

Ordering and shipping details

Category	22569-MAGELIS XBT-GT (AND XBT-G)
Discount Schedule	MC2
GTIN	3606489909499
Nbr. of units in pkg.	1
Package weight(Lbs)	30.51 oz (865.0 g)
Returnability	Yes
Country of origin	CN

Packing Units

Unit Type of Package 1	PCE
Package 1 Height	2.74 in (6.961 cm)
Package 1 width	7.30 in (18.532 cm)
Package 1 Length	10.62 in (26.974 cm)
Unit Type of Package 2	P12
Number of Units in Package 2	192
Package 2 Weight	6612.49 oz (187464.0 g)
Package 2 Height	37.40 in (95 cm)
Package 2 width	31.50 in (80 cm)
Package 2 Length	47.24 in (120 cm)
Unit Type of Package 3	S03
Number of Units in Package 3	8
Package 3 Weight	262.29 oz (7436.0 g)
Package 3 Height	11.81 in (30 cm)
Package 3 width	11.81 in (30 cm)
Package 3 Length	15.75 in (40 cm)

Offer Sustainability

Sustainable offer status	Green Premium product
California proposition 65	WARNING: This product can expose you to chemicals including: Lead and lead compounds, which is known to the State of California to cause cancer and birth defects or other reproductive harm. For more information go to www.P65Warnings.ca.gov
REACH Regulation	REACH Declaration
EU RoHS Directive	Pro-active compliance (Product out of EU RoHS legal scope) EU RoHS Declaration
Mercury free	Yes
RoHS exemption information	Yes
China RoHS Regulation	China RoHS Declaration
Environmental Disclosure	Product Environmental Profile
Circularity Profile	End Of Life Information
WEEE	The product must be disposed on European Union markets following specific waste collection and never end up in rubbish bins.
Upgradeability	Upgradeable Through Digital Modules And Upgraded Components

Contractual warranty

Warranty	18 months
----------	-----------

Display and Rear Modules

Dimensions

mm
in.

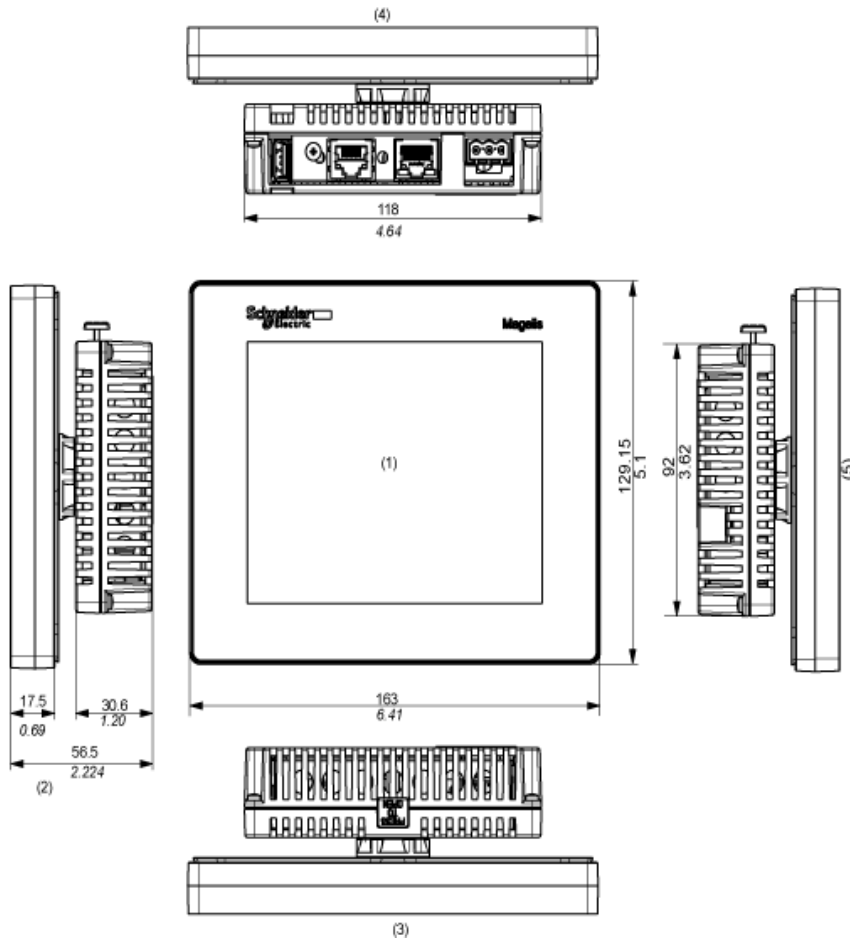

- (1) Front
- (2) Right side
- (3) Top
- (4) Bottom
- (5) Left side

Rear Module

Dimensions

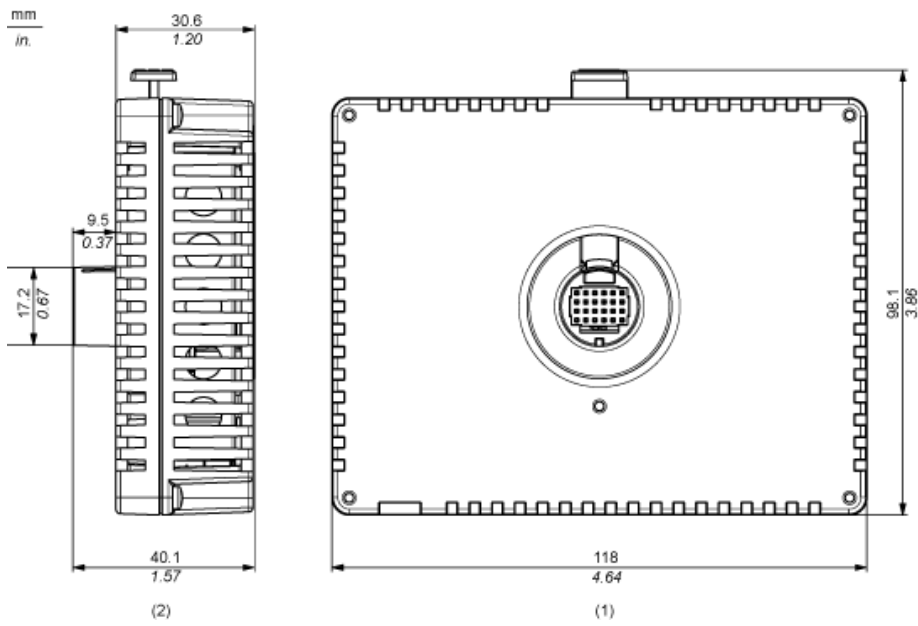

- (1) Front
- (2) Right Side

Display Module

Dimensions

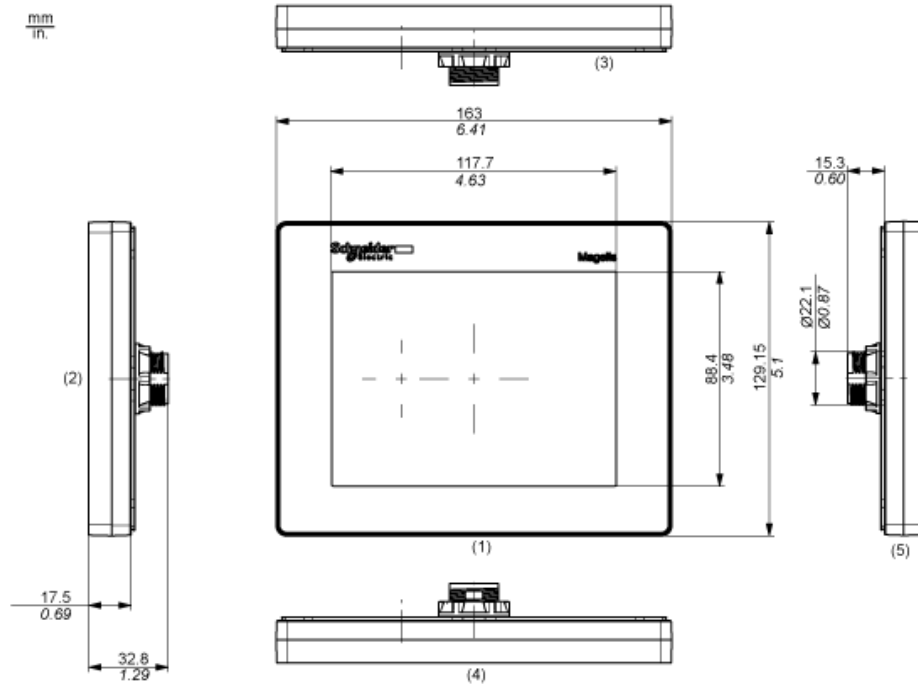

- (1) Front
- (2) Right Side
- (3) Bottom
- (4) Top
- (5) Left Side

Clearance

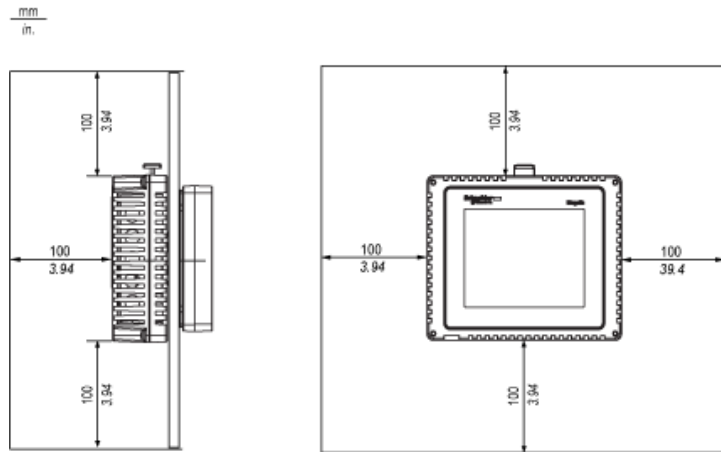

Panel Cut-out Dimensions

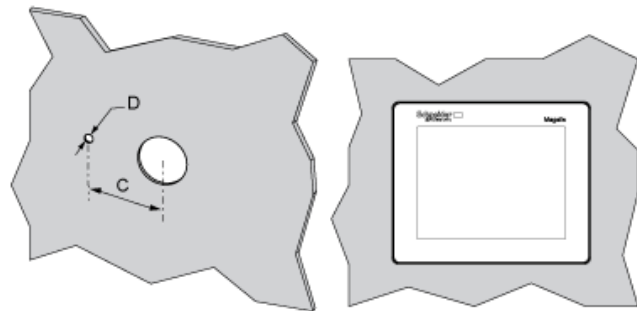

C (mm)	C (in.)	D (mm)	D (in.)
+0	+0	+0	+0
30.00	1.18	4.00	0.15
-0.20	-0.007	-0.20	-0.007

NOTE: With the tee option, the rotating torque that can be supported by the display module is 6 Nm (53.10 in-lb).