

3090 SCCT

5A Split-Core Current Transducers

Quick Installation Guide
Z207506-0C
06/2017

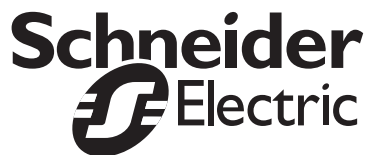

Safety Information

Important Information

Read these instructions carefully and look at the equipment to become familiar with the device before trying to install, operate, service or maintain it. The following special messages may appear throughout this bulletin or on the equipment to warn of potential hazards or to call attention to information that clarifies or simplifies a procedure.



The addition of either symbol to a "Danger" or "Warning" safety label indicates that an electrical hazard exists which will result in personal injury if the instructions are not followed.



This is the safety alert symbol. It is used to alert you to potential personal injury hazards. Obey all safety messages that follow this symbol to avoid possible injury or death.

⚠ DANGER

DANGER indicates an hazardous situation which, if not avoided, **will result in death** or serious injury.

⚠ WARNING

WARNING indicates an hazardous situation which, if not avoided, **could result in death** or serious injury.

⚠ CAUTION

CAUTION indicates an hazardous situation which, if not avoided, **could result in death** or serious injury.

NOTICE

NOTICE is used to address practices not related to physical injury.

Please Note

Electrical equipment should be installed, operated, serviced, and maintained only by qualified personnel. No responsibility is assumed by Schneider Electric for any consequences arising out of the use of this material. A qualified person is one who has skills and knowledge related to the construction, installation, and operation of electrical equipment and has received safety training to recognize and avoid the hazards involved.

Page 2

Safety Precautions

Installation, wiring, testing and service must be performed in accordance with all local and national electrical codes.

⚠ DANGER

HAZARD OF ELECTRIC SHOCK, EXPLOSION, OR ARC FLASH

- Apply appropriate personal protective equipment (PPE) and follow safe electrical work practices. See NFPA 70E in the USA or applicable local standards.
- This equipment must only be installed and serviced by qualified electrical personnel.
- Turn off all power supplying equipment before working on or inside the equipment.
- Product may use multiple voltage/power sources. Disconnect all sources of power before servicing.
- Always use a properly rated voltage sensing device to confirm power is off.
- Do not depend on this product for voltage indication.
- Current transformer secondaries must be shorted or connected to a burden at all times.
- Products rated for basic insulation must be installed on insulated conductors.
- Replace all doors, covers, and protective devices before powering the equipment.
- Install device in an appropriate electrical and fire enclosure per local regulations.
- This product is not intended for life or safety applications.

Failure to follow these instructions will result in death or serious injury.

⚠ WARNING

RISK OF INJURY OR EQUIPMENT DAMAGE

Do not apply current transducers to circuits having a phase-to-phase voltage greater than their voltage rating unless adequate additional insulation is applied between the primary conductor and the current transducers.

Failure to follow these instructions may result in injury, fine or equipment damage.

Introduction

The 3090 SCCT Series of split-core current transducers provide secondary amperage proportional to the primary (sensed) current. For use with power meters, data loggers, chart recorders and other instruments, the 3090 SCCT Series provides a cost-effective means to transform electrical service amperates to a 0 to 5 A level compatible with monitoring equipment.

The 3090 SCCT is primarily used for existing equipment where installation ease in connecting to energy management and instrumentation systems is beneficial.

Specifications

Type	Description
Output at Rated Current	5 A
Accuracy	±1% of reading from 5% to 100% of rated current specified with the conductor(s) centered through the CT window
Frequency Range	50/60 Hz
Leads	18 AWG, 6 ft. (1.8 m) standard length
Operating Temperature Range	-15 to 60 °C (5° to 140 °F)
Storage Temperature Range	-40 to 70 °C (-40 to 158 °F)
Humidity Range	0 to 95% non-condensing
Max. Voltage L-N Sensed Conductor	600 VAC (basic insulation rating) 300 VAC (reinforced insulation rating)
Altitude of Operation	3 km max.
Mounting Location	Not suitable for wet locations. For indoor use only.
Approvals	IEC 61010-1; UL 61010-1
Installation Category	Cat. III, Pollution Degree 2

Part Number Information

Model	Amperage	CT Size	Full Scale Accuracy	Burden Capacity (VA)
3090SCCT022	200	2	1%	2.5
3090SCCT032	300	2	1%	2.5
3090SCCT043	400	3	1%	5
3090SCCT063	600	3	1%	5
3090SCCT083	800	3	1%	12.5
3090SCCT084	800	4	1%	5
3090SCCT124	1200	4	1%	22.5
3090SCCT164	1600	4	1%	45
3090SCCT204	2000	4	1%	45

Note: Accuracy is specified with the primary conductor(s) centered in the CT window.

Dimensions

200 - 300 Amp
 A = 3.8" (95 mm)
 B = 1.5" (38 mm)
 C = 1.3" (32 mm)
 D = 1.1" (29 mm)
 E = 3.9" (107 mm)
 F = 4.8" (121 mm)

400 - 800 Amp
 A = 4.9" (124 mm)
 B = 2.9" (73 mm)
 C = 2.5" (62 mm)
 D = 1.1" (29 mm)
 E = 5.3" (141 mm)
 F = 5.9" (150 mm)

800 - 2000 Amp
 A = 4.9" (124 mm)
 B = 5.5" (140 mm)
 C = 2.5" (62 mm)
 D = 1.1" (29 mm)
 E = 8.1" (207 mm)
 F = 5.9" (150 mm)

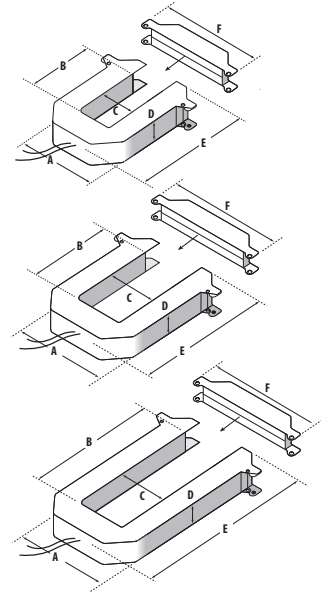

Installation

1. Turn off and lock out power to the primary circuit before installing these current transducers.
2. Use a properly rated voltage sensing device to confirm that power is off.
3. Connect the transducer output leads to the meter inputs. The white wire is the X1 lead.
4. Release the clasp on one side of the CT and open it on the hinge. Check the core ends on both sections of the CT to ensure there is no rust or debris in the closure areas.

Page 5

Page 6

5. Wrap the CT around the primary lead. A label on the product indicates the source side.

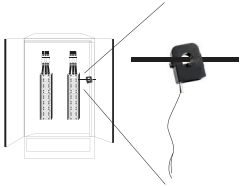

6. Close the CT until the clasp clicks into place to ensure that the contact surfaces are firmly seated.

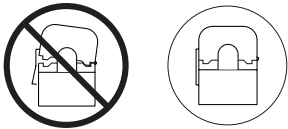

NOTE: The 3090 SCCT devices have a detachable I-bar. If the I-bar is removed, re-orient it according to the markings on the core surface, then re-attach it. In any application where fault currents can exceed 20 times the rated current of the CT, use wire ties or similar fasteners to secure both sides of the I-bar to the CT housing.

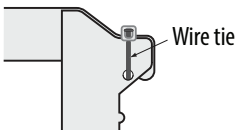

7. Reconnect power to the panel.

Schneider Electric

35, rue Joseph Monier
 CS 30323
 F - 92506 Rueil Malmaison Cedex
www.schneider-electric.com

As standards, specifications, and designs change from time to time, please ask for confirmation of the information given in this publication.

© 2017 Schneider Electric. All Rights Reserved.

Z207506-0C 06/2017

Page 7