

ONE SINGLE POLE, ONE PLUG-ON SPACE TYPE HOM OR HOMP ONLY. TWO POLE TYPE HOM OR HOMA (15-125A) MAY PLUG ON TWO ADJACENT SPACES. TWO POLE TYPE HOMA (150-200A) MAY PLUG ON FOUR ADJACENT SPACES. TOTAL CIRCUIT BREAKER HANDLE RATING NOT TO EXCEED 165A PER BRANCH CIRCUIT CONNECTOR.

A SQUARE D UL LISTED SECONDARY SURGE ARRESTER MAY PLUG ON TWO ADJACENT SPACES. ORDER CATALOG NO. HOM2175SB

KNOCKOUTS		
SYMBOL	CONDUIT SIZE	
	IN	MM
A	.50	13
B	.75	19
C	1.00	25
D	1.25	32
E	1.50	38
F	2.00	51
G	2.50	64
H	3.00	76

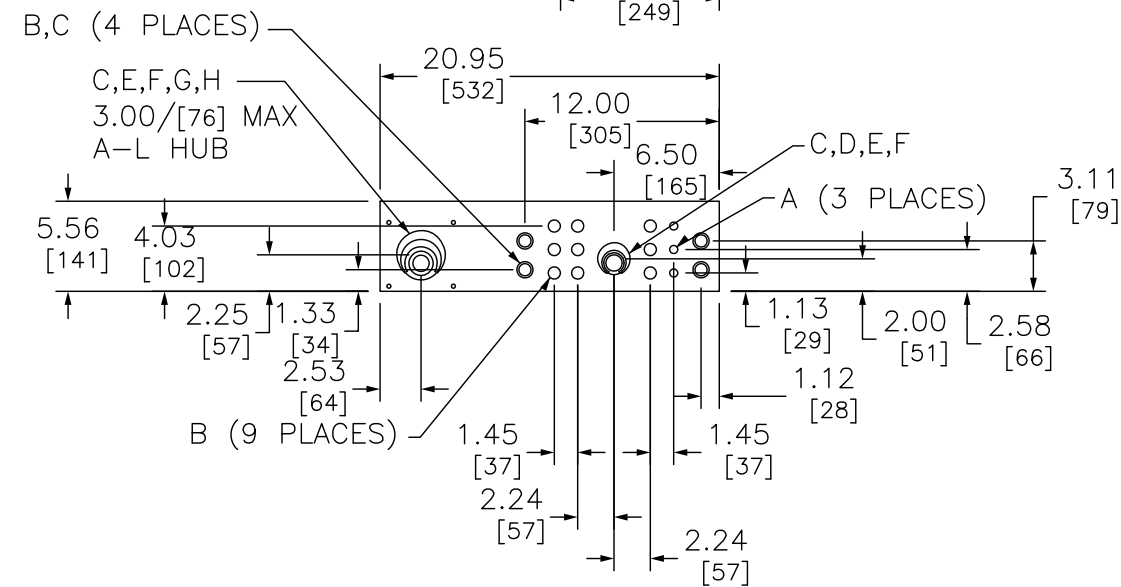

SC42M200PS

DUAL DIMENSIONS: INCHES MILLIMETERS

AMPERE RATING	BUS RATING (AMPS)	FACTORY INSTALLED BYPASS TYPE	SHORT CIRCUIT CURRENT RATING	CATALOG NUMBER	SERIES	SPACES	MAXIMUM NUMBER OF SINGLE POLE HOM CIRCUITS	LINE SIDE PHASE & NEUTRAL LUGS (AWG/KCMIL)	LARGE BRANCH NEUTRAL AWG
200	225	NONE	22K	SC42M200PS	M01	42	42	#4-250 CU/AL	#14-2/0 CU/AL
200	225	NONE	22K	SC42M200PSH*	M01	42	42	#4-250 CU/AL	#14-2/0 CU/AL

NOTES:  
 FINISH - GRAY BAKED ENAMEL POWDER COAT PAINT OVER CLEANED GALVANNEALED STEEL.  
 MAXIMUM SYSTEM VOLTAGE: 120/240 VAC 1Ø 3W.  
 UL LISTED - FILE E-6294  
 SUITABLE ONLY FOR USE AS SERVICE EQUIPMENT.  
 SUITABLE FOR UNDERGROUND/OVERHEAD SERVICE.  
 MEETS EUSERC SPECIFICATIONS.  
 \* THIS UNIT IS A SPECIAL THAT CONTAINS A FACTORY INSTALLED A250L HUB ON THE BOTTOM ENDWALL.

COMBINATION SERVICE ENTRANCE DEVICES  
 RING TYPE  
 RAINPROOF NEMA TYPE 3R ENCLOSURE  
 SURFACE ONLY



DWG# PWFDS-SYRS-0086  
 NO.