

DETAIL A
BOTTOM
MOUNTING
BRACKET

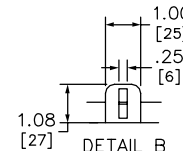

DETAIL B
COVER
SEALING
LATCH

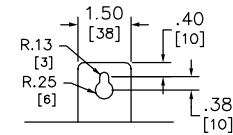

DETAIL C
TOP
MOUNTING
BRACKET

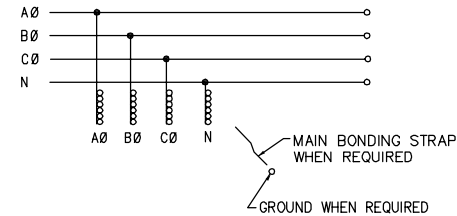

KNOCKOUTS		
SYMBOL	CONDUIT SIZE	
	IN	MM
A	.50	13
B	.75	19
D	1.25	32
E	1.50	38
F	2.00	51
G	2.50	64
H	3.00	76
I	3.50	89
J	4.00	102

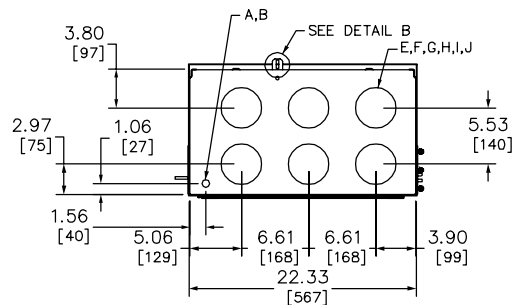

NOTE: WHEN INSTALLED AT 1600A, THIS TAP BOX MUST BE CENTER MOUNTED WITH BRANCH UNITS CONNECTED TO BOTH SIDES OF THIS MAIN DEVICE. IF INSTALLED AT 1200A, CAPACITY THIS TAP BOX MUST BE CENTER MOUNTED WHEN USED WITH BRANCH UNITS SUPPLIED WITH 800A HORIZONTAL CROSS BUS.

ADDITIONAL "FEED-THROUGH" TERMINALS MAY BE FIELD INSTALLED. ORDER KIT NUMBER EZM1600FTLK3. KIT INCLUDES (24) LUGS AND MOUNTING HARDWARE.

DUAL DIMENSIONS: INCHES
MILLIMETERS

NOTES:
FINISH - GRAY BAKED ENAMEL POWDER COAT PAINT OVER CLEANED GALVANNEALED STEEL.
UL LISTED - FILE-10582, VOL. M, E131840, VOL. M.
SUITABLE FOR USE ON THE LINE SIDE OF SERVICE EQUIPMENT.
MAIN HORIZONTAL CROSS BUS RATED AT 1200 AMPERES.
MAIN DEVICES ARE SEALABLE BY UTILITY.
GANGABLE MULTI-METERING EQUIPMENT IS DESIGNED FOR WALL MOUNTING ONLY.
(NOT SUITABLE FOR FLOOR STANDING EQUIPMENT).

SYSTEM TYPE	MAIN RATING (AMPERES)	CATALOG NUMBER *	LINE PHASE AND NEUTRAL LUG WIRE RANGE FOR AL OR CU CONDUCTORS (FACTORY INSTALLED)	GROUND LUG WIRE RANGE (FACTORY INSTALLED)
3Ø 4W 208Y/120VAC OR 240/120VAC DELTA	1600	EZM31600TB	(6) 1/0-600 OR (12) 1/0 - 300	(1) #6-300

*SERIES M03

EZ METER-PAK GANGABLE
MULTI-METERING EQUIPMENT
1600A 3PH 4W MAIN LUGS TERMINAL BOXES
OVERHEAD/UNDERGROUND FEED
RAINFOOF NEMA TYPE 3R ENCLOSURES



DWG# 3374
NO.