



Main

Range of Product	Harmony XAP
Product or Component Type	Empty control station without hinges
Device short name	XAPA
Product front plate size	85 x 146 mm
Usable depth	3.27 in (83 mm)
Number of cut-out	Undrilled
Colour of base of enclosure	Grey
Colour of cover	Grey
Material	Glass reinforced polyester
Cable entry	Undrilled
Device mounting	Flush
IP degree of protection	IP65 IEC 60529 IP69 NF C 20-010 IP69K
Resistance to chemical agents	High resistant to acids High resistant to all solvents High resistant to bases High resistant to diesel High resistant to mineral salts High resistant to oils and greases High resistant to petrol High resistant to sea water

Complementary

Net Weight	1.04 lb(US) (0.47 kg)
Flame retardance	M3 conforming to CSTB VO conforming to UL 94

Environment

Protective treatment	TC TH
Ambient Air Temperature for Storage	-40...158 °F (-40...70 °C)
Ambient Air Temperature for Operation	-40...158 °F (-40...70 °C)
Overvoltage category	Class II IEC 60536 Class II NF C 20-030
Fire resistance	1562 °F (850 °C) NF C 20-455 1760 °F (960 °C) IEC 92

Ordering and shipping details

Category	22475-WALL STATIONS
Discount Schedule	CS2
GTIN	3389110313154
Nbr. of units in pkg.	1
Package weight(Lbs)	18.06 oz (512.0 g)
Returnability	Yes
Country of origin	FR

Packing Units

Unit Type of Package 1	PCE
Package 1 Height	4.36 in (11.064 cm)
Package 1 width	3.54 in (9 cm)
Package 1 Length	6.10 in (15.5 cm)
Unit Type of Package 2	P06
Number of Units in Package 2	113
Package 2 Weight	158.45 lb(US) (71.873 kg)
Package 2 Height	28.94 in (73.5 cm)
Package 2 width	31.50 in (80 cm)
Package 2 Length	23.62 in (60 cm)

Offer Sustainability

Sustainable offer status	Green Premium product
California proposition 65	WARNING: This product can expose you to chemicals including: Di-isodecyl phthalate (DIDP), which is known to the State of California to cause birth defects or other reproductive harm. For more information go to www.P65Warnings.ca.gov
REACH Regulation	REACH Declaration
REACH free of SVHC	Yes
EU RoHS Directive	Pro-active compliance (Product out of EU RoHS legal scope) EU RoHS Declaration
Toxic heavy metal free	Yes
Mercury free	Yes
RoHS exemption information	Yes
China RoHS Regulation	China RoHS Declaration
Environmental Disclosure	Product Environmental Profile
Circularity Profile	End Of Life Information

Contractual warranty

Warranty	18 months
----------	-----------

Dimensions and Fixing

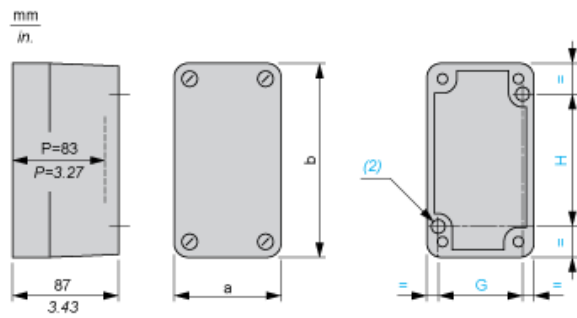

- (2) 2 x Ø 5.6 mm/0.22 in. holes, depth 12 mm/0.47 in.
P Usable depth

a		b		G		H	
mm	in.	mm	in.	mm	in.	mm	in.
85	3.35	146	5.75	70	2.76	105	4.13