

## Main

Range of Product	Zelio Logic
Product or Component Type	Compact smart relay

## Complementary

Local display	With
Number or control scheme lines	0...240 ladder 0...500 FBD
Cycle time	6...90 ms
Backup time	10 years 77 °F (25 °C)
Clock drift	12 min/year 32...131 °F (0...55 °C) 6 s/month 77 °F (25 °C)
Checks	Program memory on each power up
[Us] rated supply voltage	24 V AC
Supply voltage limits	20.4...28.8 V
Supply frequency	50/60 Hz
Maximum supply current	145 mA without extension)
Power consumption in VA	4 VA without extension
Isolation voltage	1780 V
Protection Type	Against inversion of terminals (control instructions not executed)
Discrete input number	8
Discrete input voltage	24 V AC
Discrete input current	4.4 mA
Discrete input frequency	57...63 Hz 47...53 Hz
Voltage state 1 guaranteed	>= 14 V discrete input
Voltage state 0 guaranteed	<= 5 V discrete input
Current state 1 guaranteed	>= 2 mA discrete input)
Current state 0 guaranteed	<= 0.5 mA discrete input)
Analogue input number	0
Input impedance	4.6 kOhm discrete input
Number of Outputs	4 relay
Output voltage limits	5...30 V DC relay output) 24...250 V AC
Contacts type and composition	NO relay output
Output thermal current	8 A for all 4 outputs relay output
Electrical durability	AC-12 500000 cycles 230 V, 1.5 A relay output EN/IEC 60947-5-1 AC-15 500000 cycles 230 V, 0.9 A relay output EN/IEC 60947-5-1 DC-12 500000 cycles 24 V, 1.5 A relay output EN/IEC 60947-5-1 DC-13 500000 cycles 24 V, 0.6 A relay output EN/IEC 60947-5-1
Switching capacity in mA	>= 10 mA 12 V relay output)

Operating rate in Hz	0.1 Hz at le)relay output 10 Hz no load)relay output
Mechanical durability	10000000 cycles relay output
[Uimp] rated impulse withstand voltage	4 kV EN/IEC 60947-1 and EN/IEC 60664-1
Clock	With
Response time	50 ms ladder from state 0 to state 1)discrete input 50 ms ladder from state 1 to state 0)discrete input 50...255 ms FBD from state 0 to state 1)discrete input 50...255 ms FBD from state 1 to state 0)discrete input 10 ms from state 0 to state 1)relay output 5 ms from state 1 to state 0)relay output
Connections - terminals	Screw terminals, 1 x 0.2...1 x 2.5 mm <sup>2</sup> AWG 25...AWG 14) semi-solid Screw terminals, 1 x 0.2...1 x 2.5 mm <sup>2</sup> AWG 25...AWG 14) solid Screw terminals, 1 x 0.25...1 x 2.5 mm <sup>2</sup> AWG 24...AWG 14) flexible with cable end Screw terminals, 2 x 0.2...2 x 1.5 mm <sup>2</sup> AWG 24...AWG 16) solid Screw terminals, 2 x 0.25...2 x 0.75 mm <sup>2</sup> AWG 24...AWG 18) flexible with cable end
Tightening torque	4.43 lbf.in (0.5 N.m)
Overvoltage category	III EN/IEC 60664-1
Net Weight	0.55 lb(US) (0.25 kg)

## Environment

Immunity to microbreaks	10 ms repeated 20 times
Product Certifications	C-tick CSA GL UL GOST
Standards	EN/IEC 61000-4-3 EN/IEC 61000-4-4 level 3 EN/IEC 61000-4-11 EN/IEC 60068-2-27 Ea EN/IEC 61000-4-5 EN/IEC 61000-4-6 level 3 EN/IEC 61000-4-2 level 3 EN/IEC 60068-2-6 Fc EN/IEC 61000-4-12
IP degree of protection	IP20 IEC 60529 terminal block) IP40 IEC 60529 front panel)
Environmental characteristic	EMC directive EN/IEC 61000-6-2 EMC directive EN/IEC 61000-6-3 EMC directive EN/IEC 61000-6-4 EMC directive EN/IEC 61131-2 zone B Low voltage directive EN/IEC 61131-2
Disturbance radiated/conducted	Class B EN 55022-11 group 1
Pollution degree	2 EN/IEC 61131-2
Ambient air temperature for operation	-4...104 °F (-20...40 °C) in non-ventilated enclosure IEC 60068-2-1 and IEC 60068-2-2 -4...131 °F (-20...55 °C) IEC 60068-2-1 and IEC 60068-2-2
Ambient Air Temperature for Storage	-40...158 °F (-40...70 °C)
Operating altitude	6561.68 ft (2000 m)
Maximum altitude transport	10000.00 ft (3048 m)
Relative Humidity	95 % without condensation or dripping water

## Ordering and shipping details

Category	22378-SR2,3 ZELIO 2 RELAYS
Discount Schedule	I
GTIN	3389110549157
Nbr. of units in pkg.	1
Package weight(Lbs)	8.57 oz (243.0 g)
Returnability	Yes
Country of origin	FR

## Packing Units

Unit Type of Package 1	PCE
Package 1 Height	2.68 in (6.8 cm)
Package 1 width	3.54 in (9 cm)
Package 1 Length	3.94 in (10 cm)
Unit Type of Package 2	S03
Number of Units in Package 2	30
Package 2 Weight	17.15 lb(US) (7.778 kg)
Package 2 Height	11.81 in (30 cm)
Package 2 width	11.81 in (30 cm)
Package 2 Length	15.75 in (40 cm)

## Offer Sustainability

Sustainable offer status	Green Premium product
California proposition 65	WARNING: This product can expose you to chemicals including: Lead and lead compounds, which is known to the State of California to cause cancer and birth defects or other reproductive harm. For more information go to <a href="http://www.P65Warnings.ca.gov">www.P65Warnings.ca.gov</a>
REACH Regulation	<a href="#">REACH Declaration</a>
EU RoHS Directive	Pro-active compliance (Product out of EU RoHS legal scope) <a href="#">EU RoHS Declaration</a>
Mercury free	Yes
RoHS exemption information	<a href="#">Yes</a>
China RoHS Regulation	<a href="#">China RoHS Declaration</a>
Environmental Disclosure	<a href="#">Product Environmental Profile</a>
Circularity Profile	<a href="#">End Of Life Information</a>
WEEE	The product must be disposed on European Union markets following specific waste collection and never end up in rubbish bins.
PVC free	Yes

## Contractual warranty

Warranty	18 months
----------	-----------

Compact and Modular Smart Relays

Mounting on 35 mm/1.38 in. DIN Rail

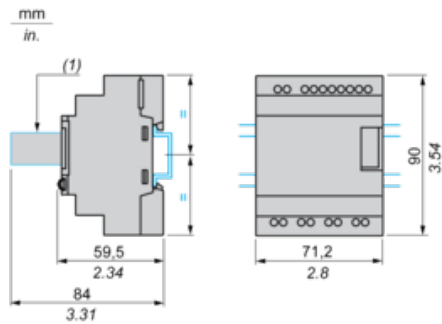

(1) With SR2USB01 or SR2BTC01

Screw Fixing (Retractable Lugs)

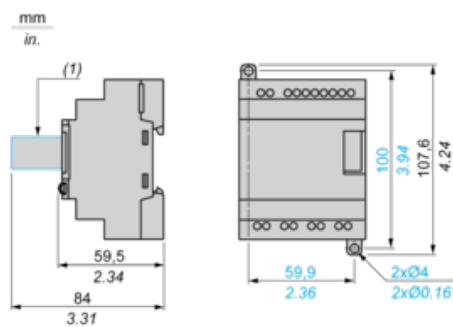

(1) With SR2USB01 or SR2BTC01

Position of Display

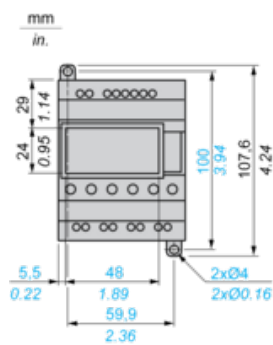

Connection of Smart Relays on AC Supply

SR••••1B, SR••••1FU

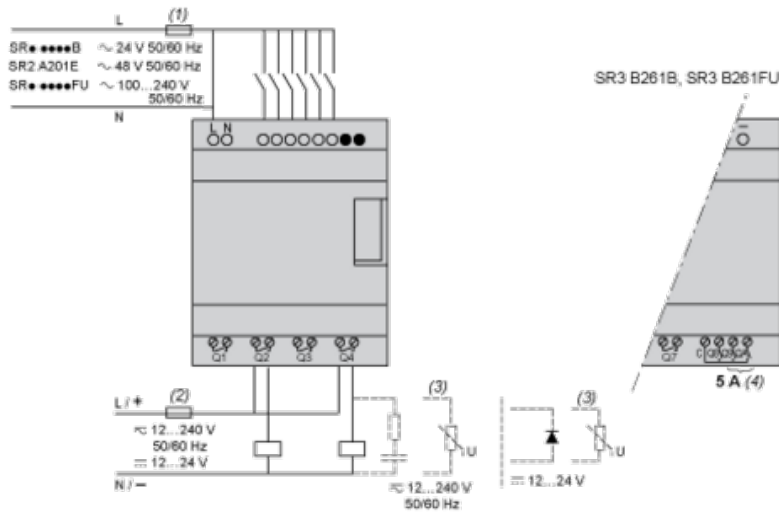

- (1) 1 A quick-blow fuse or circuit-breaker.
- (2) Fuse or circuit-breaker.
- (3) Inductive load.
- (4) Q9 and QA: 5 A (max. current in terminal C: 10 A).

With Discrete I/O Extension Module

SR3B•••B + SR3XT•••B, SR3B•••FU + SR3XT•••FU

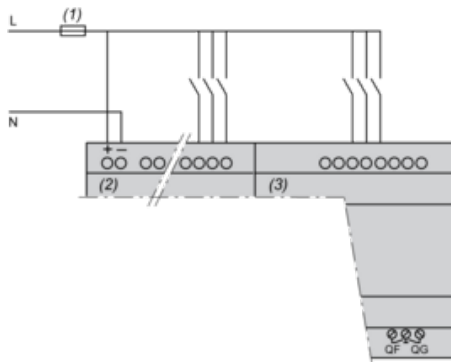

- (1) 1 A quick-blow fuse or circuit-breaker.
- NOTE: QF and QG: 5 A for SR3XT141••

Compact and Modular Smart Relays

Electrical Durability of Relay Outputs

(in millions of operating cycles, conforming to IEC/EN 60947-5-1)

AC-12 (1)

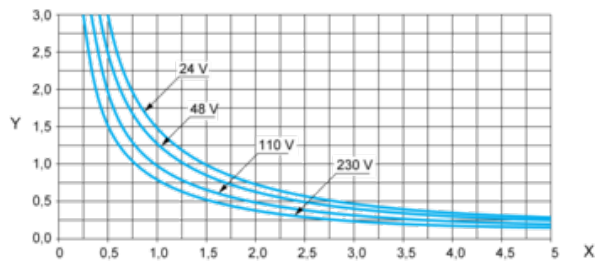

X: Current (A)

Y: Millions of operating cycles

(1) AC-12: switching resistive loads and opto-coupler isolated solid-state loads,  $\cos \geq 0.9$ .

AC-14 (1)

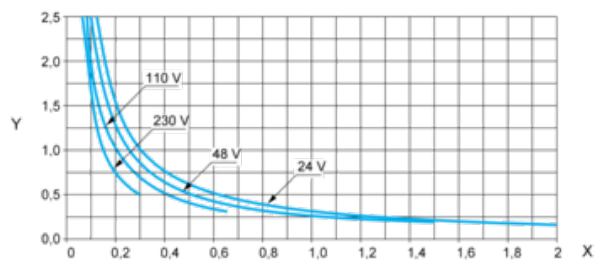

X: Current (A)

Y: Millions of operating cycles

(1) AC-14: switching small electromagnetic loads  $\leq 72$  VA, make:  $\cos = 0.3$ , break:  $\cos = 0.3$ .

AC-15 (1)

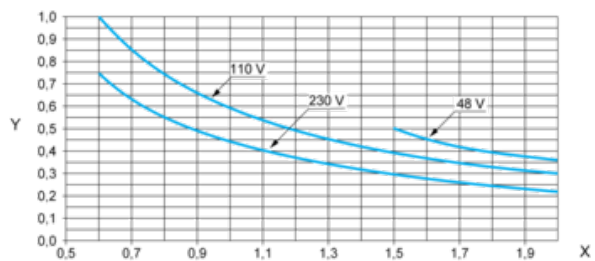

X: Current (A)

Y: Millions of operating cycles

(1) AC-15: switching electromagnetic loads  $\geq 72$  VA, make:  $\cos = 0.7$ , break:  $\cos = 0.4$ .