



Main

Range of Product	Harmony SCU
Product or Component Type	Small touchscreen display HMI
Display size	5.7 inch
Pixel resolution	320 x 240 pixels QVGA

Complementary

Display type	Backlit LED colour TFT LCD
Touch panel	Analogue
Backlight lifespan	50000 hours 65536 colours
Brightness	16 levels via touch panel
View angle horiz x vert	60° left 60° right 40° top 60° bottom
Character font	Korean Chinese (simplified Chinese) ASCII Taiwanese (traditional Chinese) Japanese (ANK, Kanji)
Height	5.08 in (129.15 mm)
Width	6.42 in (163 mm)
Depth	5.09 in (129.4 mm)
Net Weight	0.89 lb(US) (0.405 kg)

Ordering and shipping details

Category	22569-MAGELIS XBT-GT (AND XBT-G)
Discount Schedule	MC2
GTIN	3595864149059
Nbr. of units in pkg.	1
Package weight(Lbs)	23.28 oz (660.0 g)
Returnability	Yes
Country of origin	CN

Packing Units

Unit Type of Package 1	PCE
Package 1 Height	7.24 in (18.4 cm)
Package 1 width	2.20 in (5.6 cm)
Package 1 Length	10.51 in (26.7 cm)

Offer Sustainability

Sustainable offer status	Green Premium product
California proposition 65	WARNING: This product can expose you to chemicals including: Lead and lead compounds, which is known to the State of California to cause cancer and birth defects or other reproductive harm. For more information go to www.P65Warnings.ca.gov
REACH Regulation	REACH Declaration
EU RoHS Directive	Pro-active compliance (Product out of EU RoHS legal scope) EU RoHS Declaration
Mercury free	Yes
RoHS exemption information	Yes
China RoHS Regulation	China RoHS Declaration
Environmental Disclosure	Product Environmental Profile
Circularity Profile	End Of Life Information
WEEE	The product must be disposed on European Union markets following specific waste collection and never end up in rubbish bins.
Upgradeability	Upgradeable Through Digital Modules And Upgraded Components

Contractual warranty

Warranty	18 months
----------	-----------

Dimensions of 5.7-inches Display Module

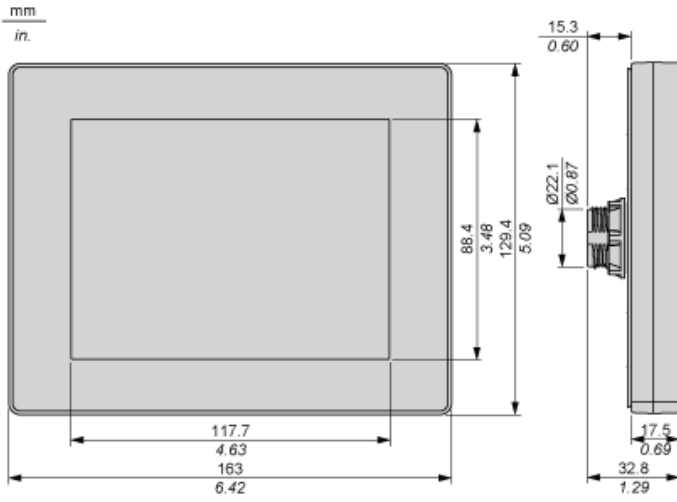

Mounting Without an Anti-Rotation Tee

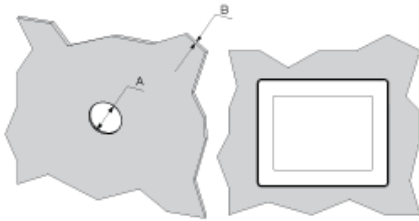

A	B (1)	B (2)
22.50 ^{0/-0.30} mm (0.88 ^{0/-0.01} in.)	1.5...6 mm (0.06...0.23 in.)	3...6 mm (0.11...0.23 in.)

Mounting With an Anti-Rotation Tee

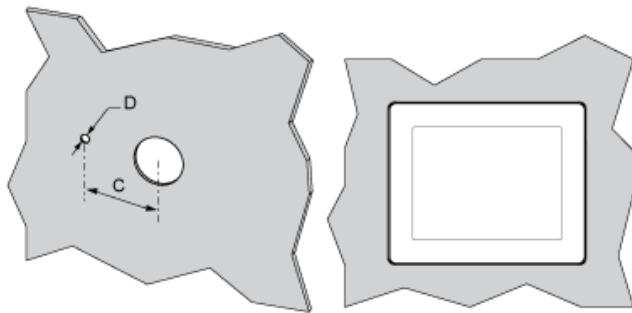

C	D
30 ^{0/-0.20} mm (1.18 ^{0/-0.0007} in.)	4 ^{0/-0.20} mm (0.15 ^{0/-0.0007} in.)