



MILBANK[®]
ENERGY AT WORK

UC3436-XL



Catalog Number	UC3436-XL
Marketing Product Description	6 Terminal Ring Type Small Closing Plate Test Switch Provision
UPC	784572144507
Length (IN)	5.125
Width (IN)	12
Height (IN)	20
Brand Name	Milbank
Type	Ring Type Meter Socket
Application	Meter Socket
Standard	UL Listed;Type 3R
Voltage Rating	600 Volts Alternating Current
Amperage Rating	20 Continuous Ampere
Phase	1 Phase
Frequency Rating	60 Hertz
Size	5.125L x 12W x 20H
Number Of Cutouts	0
Cutout Size	No Main Breaker
Cable Entry	Overhead or Underground
Terminal	Single Mechanical
Insulation	Glass Polyester
Mounting	Surface Mount

Enclosure	G90 Galvanized Steel with Powder Coat Finish
Jaw Quantity	6 Terminal
Bypass Type	No Bypass
Number of Meter Positions	1 Position
Equipment Ground	Ground Lug
Hub Opening	Small Closing Plate
Line Side Wire Range	12 - 10 AWG
Load Side Wire Range	12 - 10 AWG
Number Of Receptacles	0

Please consult serving utility for their requirements prior to ordering or installing, as specifications and approvals vary by utility and may require local electrical inspector approval. All installations must be installed by a licensed electrician and must comply with all national and local codes, laws and regulations. Milbank reserves the right to make changes in specifications and features shown without notice or obligation.

FEATURE TABLE		
ITEM	QTY	DESCRIPTION
A	4	STD. MNTG. EMBOSS
B	7	½, ¾, 1, 1¼, 1½, 2 CONC. K.O.

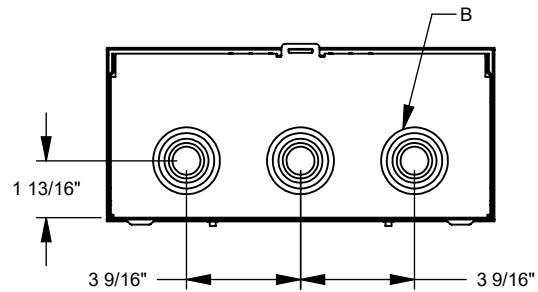
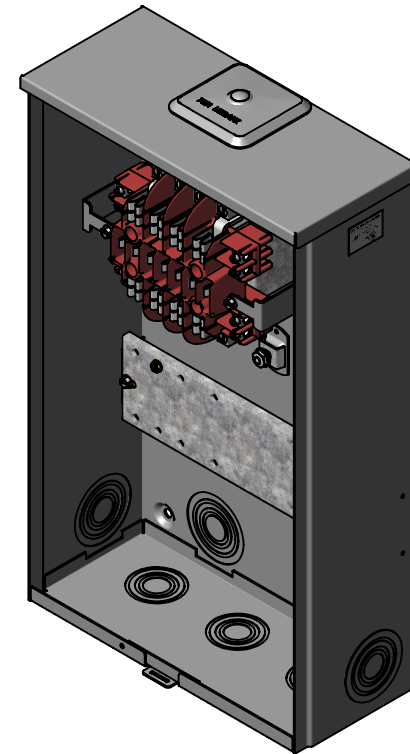
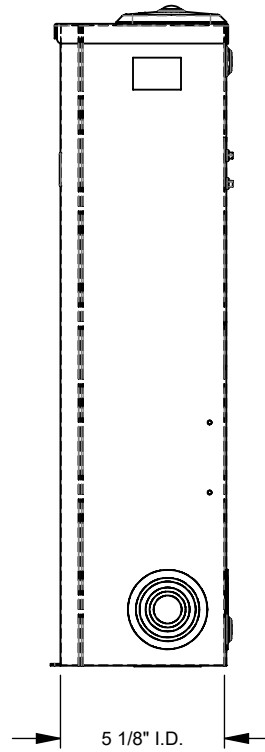
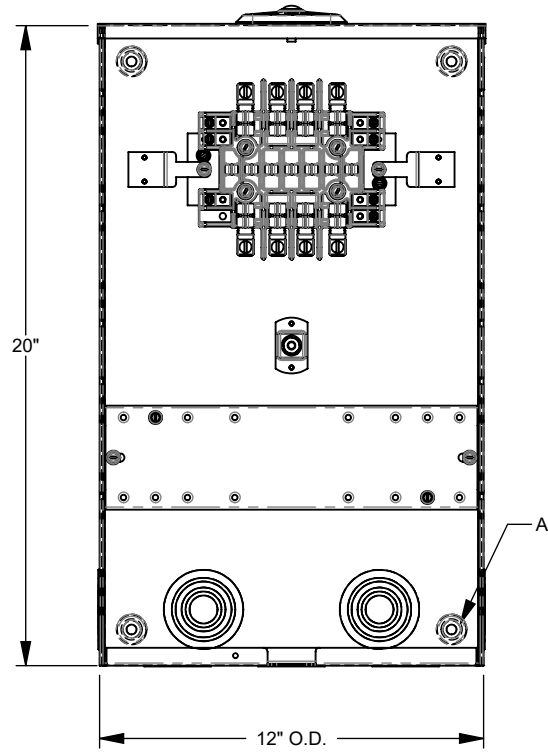

Version:

1

**All dimensions are +/- 1/16".
Drawing views are not to scale.**

Please consult serving utility for their requirements prior to ordering or installing, as specifications and approvals vary by utility, and may require local electrical inspector approval. All installations must be installed by a licensed electrician and must comply with all national and local codes, laws and regulations. Milbank reserves the right to make changes in specifications and features shown without notice or obligation.