

SCREW: SEE CHART	MATERIAL: ALUMINUM	REV: N	<b>ILSCO</b> connections matter	
CAT. NO.: TA-500-S	PLATING: EL-TIN	DRAWN BY: CLH	SCALE: 1:1	800-776-9775 www.ilsco.com
INFORMATION SHEET: SEE CHART	MARKING: SEE CHART	DATE: 9/20/2007	SIZE: A	DWG. NO. <b>D3692</b>
				SHEET: 1 OF 1

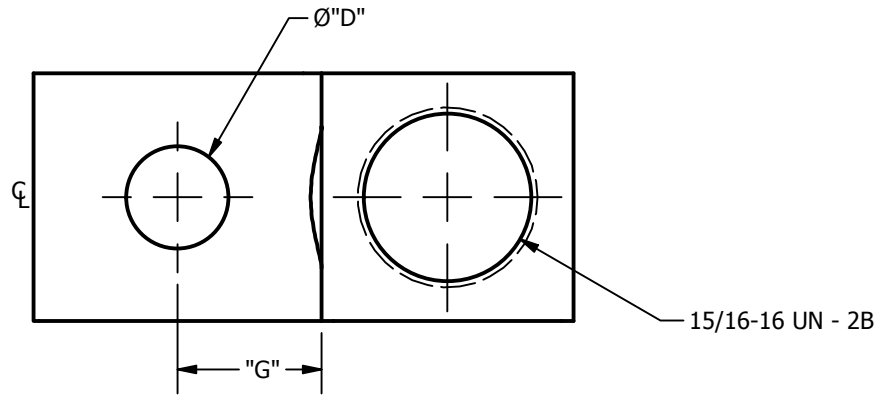

SEE CHART FOR SCREW

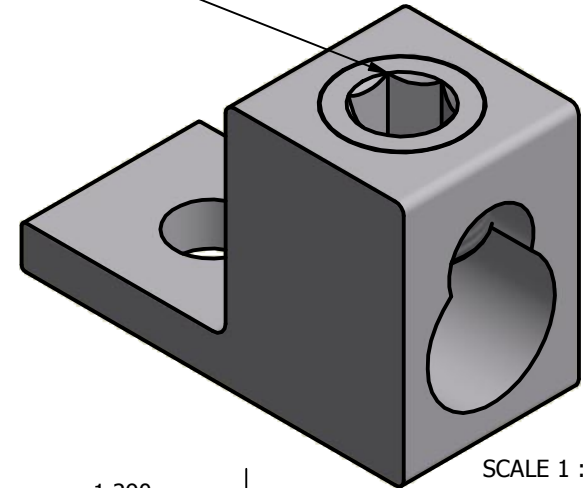

SCALE 1 : 1

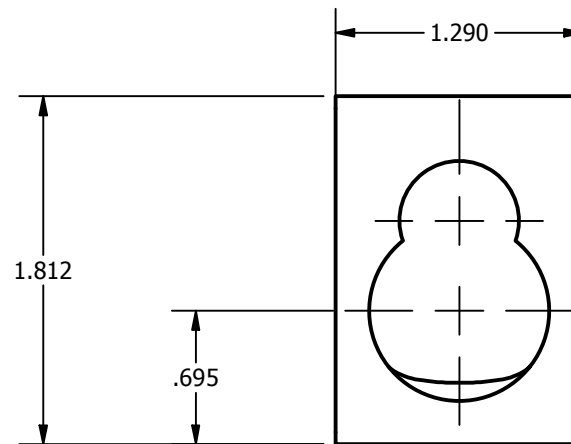
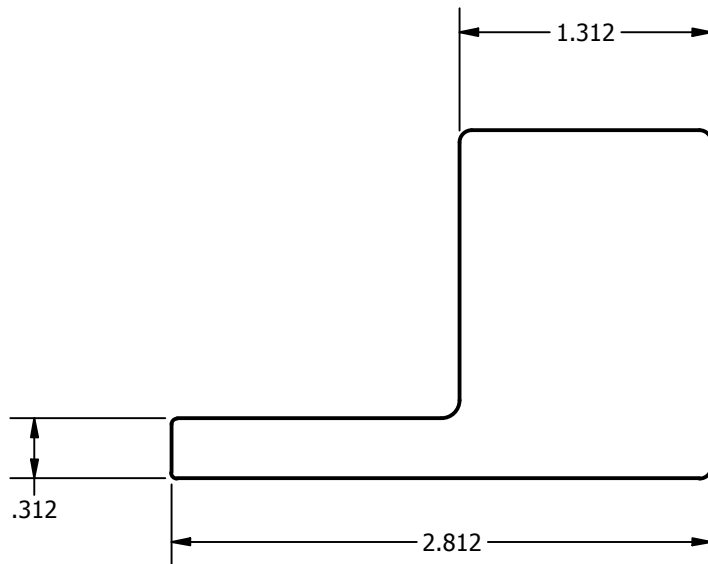

DEVIATION	"G"	"D"	MARKING	FORM	SCREW
-11	.885	.406	BKB, ADR6004, 600MCM-4, AL9CU	FORM 96	E0945
-22	.750	.531	ILSCO, D3692, 600MCM-4, TWO 250MCM-1/0, AL9CU	FORM 1	E0945
-23	.885	.406	ILSCO, D3692, TA500S, 600MCM-4, TWO 250MCM-1/0, AL9CU	FORM 1	E0945
-24	.885	.562	ILSCO, D3692, TA500S, 600MCM-4, TWO 250MCM-1/0, AL9CU	FORM 1	E0945
-25	.885	.406	ILSCO, D3692, TA500S, 600MCM-4, TWO 250MCM-1/0, AL9CU	FORM 161	E1402