



### Main

Range of Product	Harmony XVU
Product or Component Type	Modular tower light
Mounting diameter	2.36 in (60 mm)
Accessory / Separate Part Type	Long body tube
Accessory / separate part category	Mounting and fixing accessory

### Complementary

Material	PBT + ABS (UL94-V0) PC (UL94 V-0)
Product Compatibility	XVU
[Us] rated supply voltage	110...240 V AC 24 V AC/DC
Length	3.94 in (100 mm)
Net Weight	0.21 lb(US) (0.093 kg)

### Environment

Product Certifications	CE UL CSA
Ambient Air Temperature for Storage	-40...158 °F (-40...70 °C)
Ambient Air Temperature for Operation	-13...122 °F (-25...50 °C)
IP degree of protection	IP65

### Ordering and shipping details

Category	22618-XVU TOWER LIGHTS
Discount Schedule	XV
GTIN	3606480555978
Nbr. of units in pkg.	1
Package weight(Lbs)	9.38 oz (266.0 g)
Returnability	No
Country of origin	ID

### Packing Units

Unit Type of Package 1	PCE
Package 1 Height	3.54 in (9 cm)
Package 1 width	3.58 in (9.1 cm)
Package 1 Length	10.55 in (26.8 cm)
Unit Type of Package 2	S04
Number of Units in Package 2	24
Package 2 Weight	15.43 lb(US) (7.0 kg)
Package 2 Height	11.81 in (30 cm)

Package 2 width	15.75 in (40 cm)
Package 2 Length	23.62 in (60 cm)

## Offer Sustainability

Sustainable offer status	Green Premium product
California proposition 65	WARNING: This product can expose you to chemicals including: Lead and lead compounds, which is known to the State of California to cause cancer and birth defects or other reproductive harm. For more information go to <a href="http://www.P65Warnings.ca.gov">www.P65Warnings.ca.gov</a>
REACH Regulation	<a href="#">REACH Declaration</a>
EU RoHS Directive	Pro-active compliance (Product out of EU RoHS legal scope) <a href="#">EU RoHS Declaration</a>
Mercury free	Yes
RoHS exemption information	<a href="#">Yes</a>
China RoHS Regulation	<a href="#">China RoHS Declaration</a>
Environmental Disclosure	<a href="#">Product Environmental Profile</a>
Circularity Profile	<a href="#">End Of Life Information</a>

---

Extender Unit

---

Dimensions

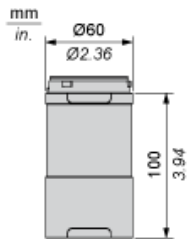

Modular Tower Lights Mounting

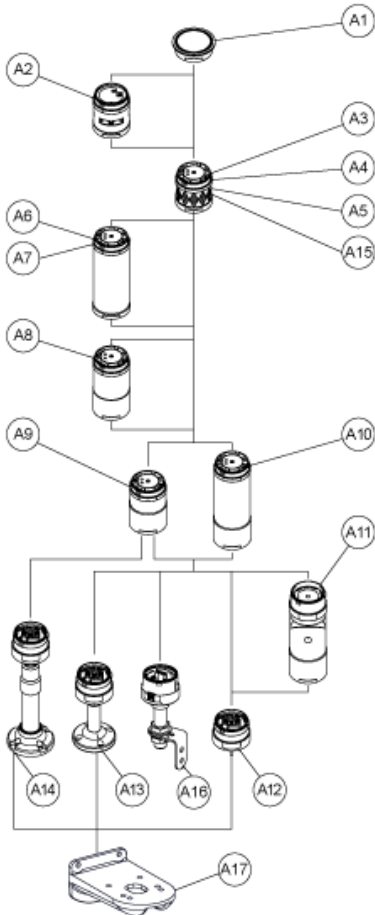

Drawing	Part number	Part name
A1	-	Top cover
-	Top cover (Silver)	
A2	XVUC9S	Buzzer unit
XVUC9SQ	Buzzer unit (Silver)	
A3	XVUC23	Green LED unit
XVUC24	Red LED unit	
XVUC25	Orange LED unit	
XVUC26	Blue LED unit	
XVUC27	White LED unit	
XVUC28	Yellow LED unit	
A4	XVUC29	Multi-LED unit
A5	XVUC29P	Multi-LED unit, Pulse signal
A6	XVUC9V	Sound unit
A7	XVUC9VP	Sound unit, Pulse signal
A8	XVUC020	Extender
XVUC020Q	Extender (Silver)	
A9	XVUC21B	DC body

Drawing	Part number	Part name
XVUC21BQ	DC body (Silver)	
A10	XVUC21M	AC body NPN
XVUC21MP	AC body PNP	
XVUC21MQP	AC body PNP (Silver)	
A11	XVUZ06	Flexible option
A12	XVUZ01	Fixing Unit - Direct mounting (3 pins)
XVUZ01Q	Fixing Unit - Direct mounting (Silver,3 pins)	
XVUZ03	Fixing Unit - Direct mounting (2 pins)	
XVUZ04	Fixing Unit - Direct mounting (4 pins)	
A13	XVUZ02	Fixing Unit - Plate with Pole (100 mm)
XVUZ02Q	Fixing Unit - Plate with Pole (100 mm, Silver)	
XVUZ400	Fixing Unit - Plate with Pole (400 mm)	
XVUZ800	Fixing Unit - Plate with Pole (800 mm)	
A14	XVUZ05	Fixing Unit - Plate with adjustment pole (100-385 mm)
A15	XVUC43	Green LED unit, Flash
XVUC44	Red LED unit, Flash	
XVUC45	Orange LED unit, Flash	
XVUC46	Blue LED unit, Flash	
XVUC47	White LED unit, Flash	
XVUC48	Yellow LED unit, Flash	
A16	XVUZ100T	Fixing Unit - Metal bracket with pole (100 mm)
XVUZ250T	Fixing Unit - Metal bracket with pole(250 mm)	
XVUZ400T	Fixing Unit - Metal bracket with pole (400 mm)	
A17	XVUZ12	Fixing plate for use on vertical support - black