



Main

Product	Single Throw Safety Switch
Duty Rating	Heavy duty
Device Application	Heavy application
Disconnect Type	Fusible disconnect
Factory Installed Neutral	None
Phase	3 phase
Number of Poles	2
Current Rating	600 A
Voltage Rating	250 V DC 240 V AC
Enclosure Rating	NEMA 3R galvanized steel
Maximum Horse Power Rating	75 Hp 240 V at AC 50-60 Hz for 3 phase conforming to NEC 240.6 200 Hp 240 V at AC 50-60 Hz for 3 phase conforming to NEC 430.52 50 hp 250 V at DC

Complementary

Short Circuit Current Rating	10 KA H or K 200 kA R or J
Fuse type	H or K R or J
Mounting Type	Surface
Electrical Connection	Lugs
Wiring configuration	2-wire
Wire Size	AWG 3/0...500 kcmil copper or aluminium
Tightening torque	375 lbf.in (42.37 N.m) (AWG 3/0...500 kcmil)
Depth	10.13 in (257.30 mm)
Width	27.88 in (708.15 mm)
Height	50.31 in (1277.87 mm)
Net Weight	175.05 lb(US) (79.4 kg)

Environment

Certifications	UL listed file E2875
----------------	----------------------

Ordering and shipping details

Category	00053-H&HU SW,NEMA1,400-1200A
Discount Schedule	DE1
GTIN	785901259244
Nbr. of units in pkg.	1
Package weight(Lbs)	175.00 lb(US) (79.379 kg)
Returnability	No
Country of origin	US

The information provided in this documentation contains general descriptions and/or technical characteristics of the performance of the products contained herein. This documentation is not intended as a substitute for and is not to be used for determining suitability or reliability of these products for specific user applications. It is the duty of any such user or integrator to perform the appropriate and complete risk analysis, evaluation and testing of the products with respect to the relevant specific application or use thereof. Neither Schneider Electric Industries SAS nor any of its affiliates or subsidiaries shall be responsible or liable for misuse of the information contained herein.

Packing Units

Unit Type of Package 1	PCE
Package 1 Height	19.81 in (50.31 cm)
Package 1 width	10.98 in (27.879 cm)
Package 1 Length	3.75 in (9.53 cm)

Offer Sustainability

Sustainable offer status	Green Premium product
California proposition 65	WARNING: This product can expose you to chemicals including: Lead and lead compounds, which is known to the State of California to cause cancer and birth defects or other reproductive harm. For more information go to www.P65Warnings.ca.gov
REACH Regulation	REACH Declaration
REACH free of SVHC	Yes
EU RoHS Directive	Compliant EU RoHS Declaration
Mercury free	Yes
RoHS exemption information	Yes
China RoHS Regulation	China RoHS Declaration
Environmental Disclosure	Product Environmental Profile
PVC free	Yes
Halogen content performance	Halogen free plastic parts product

Contractual warranty

Warranty	18 months
----------	-----------

Approximate Dimensions

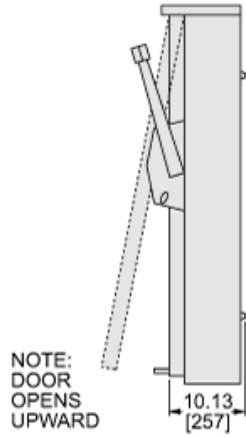
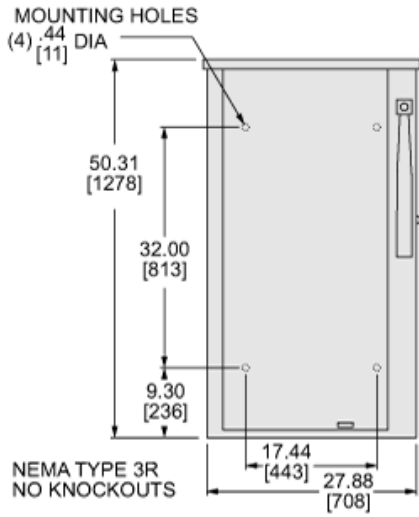

in.
[mm]

