



Main

Range of Product	Harmony XVC6
Accessory / separate part designation	Metal fixing plate
Accessory / Separate Part Type	Fixing plate
Accessory / separate part category	Mounting and fixing accessories
Product Compatibility	XVC6B4 XVC6B1 XVC6B3 XVC6B55S XVC6B35S XVC6B5 XVC6B2 XVC6B45S XVC6B25S XVC6B15S
Accessory / separate part destination	Complete pre-wired monolithic tower light
Product Specific Application	For support tube mounting

Complementary

Diameter	3.94 in (100 mm)
Height	1.18 in (30 mm)
Net Weight	0.18 lb(US) (0.08 kg)

Ordering and shipping details

Category	22617-XVC TOWER LIGHTS
Discount Schedule	XV
GTIN	3606480032745
Nbr. of units in pkg.	1
Package weight(Lbs)	6.91 oz (196.0 g)
Returnability	No
Country of origin	JP

Packing Units

Unit Type of Package 1	PCE
Package 1 Height	3.31 in (8.4 cm)
Package 1 width	4.33 in (11 cm)
Package 1 Length	4.37 in (11.1 cm)
Unit Type of Package 2	S02
Number of Units in Package 2	8
Package 2 Weight	4.28 lb(US) (1.942 kg)
Package 2 Height	5.91 in (15 cm)
Package 2 width	11.81 in (30 cm)
Package 2 Length	15.75 in (40 cm)

Offer Sustainability

California proposition 65	WARNING: This product can expose you to chemicals including: Nickel compounds, which is known to the State of California to cause cancer, and Di-isodecyl phthalate (DIDP), which is known to the State of California to cause birth defects or other reproductive harm. For more information go to www.P65Warnings.ca.gov
EU RoHS Directive	Pro-active compliance (Product out of EU RoHS legal scope) EU RoHS Declaration
Toxic heavy metal free	Yes
Mercury free	Yes
RoHS exemption information	Yes
China RoHS Regulation	China RoHS Declaration
Environmental Disclosure	Product Environmental Profile
Circularity Profile	End Of Life Information

Contractual warranty

Warranty	18 months
----------	-----------

Dimensions and Mounting

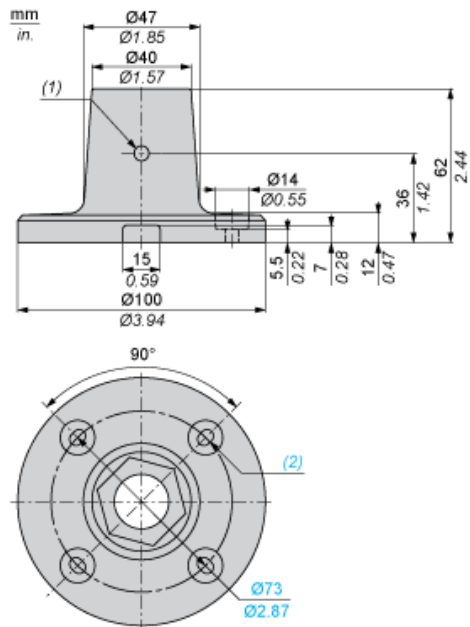

- (1) M6 (SUS)
- (2) 4 elongated holes $\varnothing 5.2\text{mm} \times 7\text{mm}$ / $\varnothing 0.20\text{ in} / 0.28\text{ in}$.