

TeSys T LTMR

Motor Management Controller Installation Guide

07/2018

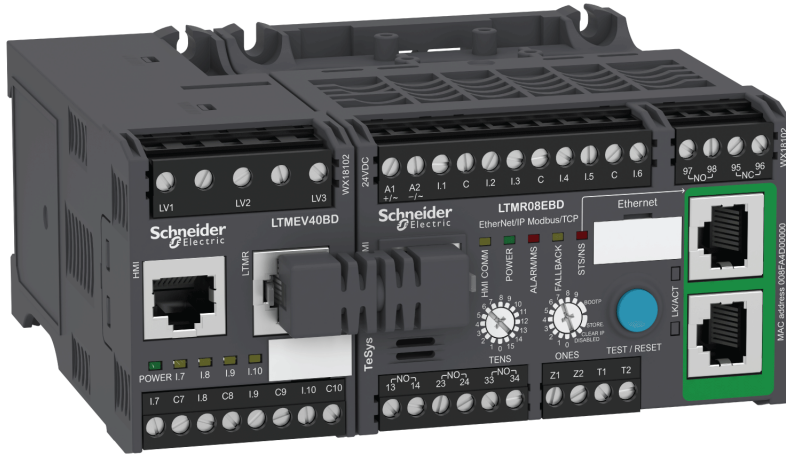

The information provided in this documentation contains general descriptions and/or technical characteristics of the performance of the products contained herein. This documentation is not intended as a substitute for and is not to be used for determining suitability or reliability of these products for specific user applications. It is the duty of any such user or integrator to perform the appropriate and complete risk analysis, evaluation and testing of the products with respect to the relevant specific application or use thereof. Neither Schneider Electric nor any of its affiliates or subsidiaries shall be responsible or liable for misuse of the information contained herein. If you have any suggestions for improvements or amendments or have found errors in this publication, please notify us.

You agree not to reproduce, other than for your own personal, noncommercial use, all or part of this document on any medium whatsoever without permission of Schneider Electric, given in writing. You also agree not to establish any hypertext links to this document or its content. Schneider Electric does not grant any right or license for the personal and noncommercial use of the document or its content, except for a non-exclusive license to consult it on an "as is" basis, at your own risk. All other rights are reserved.

All pertinent state, regional, and local safety regulations must be observed when installing and using this product. For reasons of safety and to help ensure compliance with documented system data, only the manufacturer should perform repairs to components.

When devices are used for applications with technical safety requirements, the relevant instructions must be followed.

Failure to use Schneider Electric software or approved software with our hardware products may result in injury, harm, or improper operating results.

Failure to observe this information can result in injury or equipment damage.

© 2018 Schneider Electric. All Rights Reserved.

Table of Contents



	Safety Information	5
	About the Book	7
Chapter 1	Introducing the TeSys T Motor Management System	9
	Presentation of the TeSys T Motor Management System	9
Chapter 2	Installation	11
	General Principles	12
	Dimensions	13
	Assembly	15
	Mounting	17
	Wiring - Generalities	20
	Wiring - Current Transformers (CTs)	25
	Wiring - Ground Fault Current Transformers	29
	Wiring - Temperature Sensors	31
	Wiring - Power Supply	32
	Wiring - Logic Inputs	34
	Wiring - Logic Outputs	38
	Connecting to an HMI Device	40
Chapter 3	Commissioning	45
	Introduction	46
	First Power-up	48
	Required and Optional Parameters	50
	FLC (Full Load Current) Settings	51
	Verifying System Wiring	53
	Verify Configuration	55
Chapter 4	Maintenance	57
	Detecting Problems	58
	Troubleshooting	59
	Preventive Maintenance	61
	Replacing an LTMR Controller and LTME Expansion Module	63
	Communication Warnings and Faults	64
Appendices	67
Appendix A	Configurable Parameters	69
	Main Settings	70
	Control	71
	Communication	73
	Thermal	74
	Current	75
	Voltage	77
	Power	79
	HMI	80
Appendix B	Wiring Diagrams	83
B.1	IEC Format Wiring Diagrams	84
	Overload Mode Wiring Diagrams	85
	Independent Mode Wiring Diagrams	89
	Reverser Mode Wiring Diagrams	91
	Two-Step Wye-Delta Mode Wiring Diagrams	93
	Two-Step Primary Resistor Mode Wiring Diagrams	95
	Two-Step Autotransformer Mode Wiring Diagrams	97
	Two-Speed Dahlander Mode Wiring Diagrams	99
	Two-Speed Pole Changing Mode Wiring Diagrams	101

B.2	NEMA Format Wiring Diagrams	103
	Overload Mode Wiring Diagrams	104
	Independent Mode Wiring Diagrams	108
	Reverser Mode Wiring Diagrams	110
	Two-Step Wye-Delta Mode Wiring Diagrams	112
	Two-Step Primary Resistor Mode Wiring Diagrams	114
	Two-Step Autotransformer Mode Wiring Diagrams	116
	Two-Speed Mode Wiring Diagrams: Single Winding (Consequent Pole)	118
	Two-Speed Mode Wiring Diagrams: Separate Winding	120
Glossary	123
Index	127



Important Information

NOTICE

Read these instructions carefully, and look at the equipment to become familiar with the device before trying to install, operate, service, or maintain it. The following special messages may appear throughout this documentation or on the equipment to warn of potential hazards or to call attention to information that clarifies or simplifies a procedure.



The addition of this symbol to a “Danger” or “Warning” safety label indicates that an electrical hazard exists which will result in personal injury if the instructions are not followed.



This is the safety alert symbol. It is used to alert you to potential personal injury hazards. Obey all safety messages that follow this symbol to avoid possible injury or death.

DANGER

DANGER indicates a hazardous situation which, if not avoided, **will result in** death or serious injury.

WARNING

WARNING indicates a hazardous situation which, if not avoided, **could result in** death or serious injury.

CAUTION

CAUTION indicates a hazardous situation which, if not avoided, **could result in** minor or moderate injury.

NOTICE

NOTICE is used to address practices not related to physical injury.

PLEASE NOTE

Electrical equipment should be installed, operated, serviced, and maintained only by qualified personnel. No responsibility is assumed by Schneider Electric for any consequences arising out of the use of this material.

A qualified person is one who has skills and knowledge related to the construction and operation of electrical equipment and its installation, and has received safety training to recognize and avoid the hazards involved.

About the Book



At a Glance

Document Scope

This guide describes the TeSys™ T LTMR motor management controller and LTME expansion module.

The purpose of this guide is to:

- Describe and explain the monitoring, protection, and control functions of the LTMR controller and LTME expansion module
- Provide all the information necessary to implement and support a solution that best meets your application requirements

The guide describes the four key parts of a successful system implementation:

- Installing the LTMR controller and LTME expansion module
- Commissioning the LTMR controller by setting essential parameter values
- Using the LTMR controller and LTME expansion module, both with and without additional human-machine interface devices
- Maintaining the LTMR controller and LTME expansion module

This guide is intended for:

- Design engineers
- System integrators
- System operators
- Maintenance engineers

Validity Note

This guide is valid for all LTMR controllers. Some functions are available depending on the communication protocol and the software version of the controller.

Related Documents

Title of Documentation	Description	Reference Number
TeSys T LTMR - Motor Management Controller - User Guide	This is the main user guide that introduces the complete TeSys T range and describes the main functions of the TeSys T LTMR motor management controller and LTME expansion module.	DOCA0127EN
TeSys T LTMR - Motor Management Controller - Ethernet Communication Guide	This guide describes the Ethernet network protocol version of the TeSys T LTMR motor management controller.	DOCA0129EN
TeSys T LTMR - Motor Management Controller - Modbus Communication Guide	This guide describes the Modbus network protocol version of the TeSys T LTMR motor management controller.	DOCA0130EN
TeSys T LTMR - Motor Management Controller - PROFIBUS DP Communication Guide	This guide describes the PROFIBUS DP network protocol version of the TeSys T LTMR motor management controller.	DOCA0131EN
TeSys T LTMR - Motor Management Controller - CANopen Communication Guide	This guide describes the CANopen network protocol version of the TeSys T LTMR motor management controller.	DOCA0132EN
TeSys T LTMR - Motor Management Controller - DeviceNet Communication Guide	This guide describes the DeviceNet network protocol version of the TeSys T LTMR motor management controller.	DOCA0133EN
TeSys® T LTM CU - Control Operator Unit - User Manual	This manual describes how to install, configure, and use the TeSys T LTMCU Control Operator Unit.	1639581EN
Compact Display Units - Magelis XBT N/XBT R - User Manual	This manual describes the characteristics and presentation of the XBT N/XBT R display units.	1681029EN
TeSys T LTMR Ethernet/IP with a Third-Party PLC - Quick Start Guide	This guide provides a single reference for configuring and connecting the TeSys T and the Allen-Bradley programmable logic controller (PLC).	DOCA0119EN
TeSys T LTM R Modbus - Motor Management Controller - Quick Start Guide	This guide uses an application example to describe the different steps to quickly install, configure, and use TeSys T for Modbus network.	1639572EN
TeSys T LTM R Profibus-DP - Motor Management Controller - Quick Start Guide	This guide uses an application example to describe the different steps to quickly install, configure, and use TeSys T for PROFIBUS-DP network.	1639573EN

Title of Documentation	Description	Reference Number
TeSys T LTM R CANopen - Motor Management Controller - Quick Start Guide	This guide uses an application example to describe the different steps to quickly install, configure, and use TeSys T for CANopen network.	<i>1639574EN</i>
TeSys T LTM R DeviceNet - Motor Management Controller - Quick Start Guide	This guide uses an application example to describe the different steps to quickly install, configure, and use TeSys T for DeviceNet network.	<i>1639575EN</i>
Electromagnetic Compatibility - Practical Installation Guidelines	This guide provides an insight to the electromagnetic compatibility.	<i>DEG999EN</i>
TeSys T LTM R•• - Instruction Sheet	This document describes the mounting and connection of the TeSys T LTMR motor management controller.	<i>AAV7709901</i>
TeSys T LTM E•• - Instruction Sheet	This document describes the mounting and connection of the TeSys T LTME expansion module.	<i>AAV7950501</i>
Magelis Compact Terminals XBT N/R/RT - Instruction Sheet	This document describes the mounting and connection of the Magelis XBT-N.	<i>1681014</i>
TeSys T LTM CU• - Instruction Sheet	This document describes the mounting and connection of the TeSys T LTMCU control unit	<i>AAV6665701</i>
TeSys T DTM for FDT Container - Online Help	This online help describes the TeSys T DTM and the custom logic editor embedded in the TeSys T DTM which allows the customization of the control functions of the TeSys T motor management system.	<i>1672614EN</i>
TCSMCNAM3M002P USB to RS485 Converter - Quick Reference Guide	This instruction guide describes the configuration cable between computer and TeSys T: USB to RS485	<i>BBV28000</i>
Electrical Installation Guide (Wiki version)	The aim of the Electrical Installation Guide (and now Wiki) is to help electrical designers and contractors to design electrical installations according to standards such as the IEC60364 or other relevant standards.	<i>www.electrical-installation.org</i>

You can download these technical publications and other technical information from our website at www.schneider-electric.com.

Trademark Notice

All trademarks are owned by Schneider Electric Industries SAS or its affiliated companies.

Chapter 1

Introducing the TeSys T Motor Management System

Presentation of the TeSys T Motor Management System

Aim of the Product

The TeSys T motor management system offers protection, control, and monitoring capabilities for single-phase and three-phase AC induction motors.

The system is flexible, modular, and can be configured to meet the requirements of applications in industry. The system is designed to meet the needs for integrated protection systems with open communications and a global architecture.

Highly accurate sensors and solid-state full motor protection provide better utilization of the motor. Complete monitoring functions enable analysis of motor operating conditions and faster responses to prevent system downtime.

The system offers diagnostic and statistics functions and configurable warnings and faults, allowing better prediction of component maintenance, and provides data to continuously improve the entire system.

For more details on the product, refer to the [*TeSys T L TMR Motor Management Controller User Guide*](#).

Chapter 2

Installation

Overview

This chapter describes the physical installation and assembly of the LTMR controller and the LTME expansion module. It also explains how to connect and wire the controller terminal block, including communication port wiring in both an enclosure or a switchboard.

DANGER

HAZARD OF ELECTRIC SHOCK, EXPLOSION, OR ARC FLASH

- Turn off all power supplying this equipment before working on it.
- Apply appropriate personal protective equipment (PPE) and follow safe electrical work practices.

Failure to follow these instructions will result in death or serious injury.

WARNING

UNINTENDED EQUIPMENT OPERATION

- The application of this product requires expertise in the design and programming of control systems. Only persons with such expertise should be allowed to program and apply this product.
- Follow all local and national safety codes and standards.
- Follow all electromagnetic compatibility rules described in this guide.
- Follow all installation and wiring rules described in this guide.

Failure to follow these instructions can result in death, serious injury, or equipment damage.

What Is in This Chapter?

This chapter contains the following topics:

Topic	Page
General Principles	12
Dimensions	13
Assembly	15
Mounting	17
Wiring - Generalities	20
Wiring - Current Transformers (CTs)	25
Wiring - Ground Fault Current Transformers	29
Wiring - Temperature Sensors	31
Wiring - Power Supply	32
Wiring - Logic Inputs	34
Wiring - Logic Outputs	38
Connecting to an HMI Device	40

General Principles

Functional Safety Introduction

The TeSys T motor management system is a part of a global architecture. To provide the functional safety, some risks must be analyzed such as:

- Global functional risks
- Risk of hardware and software breakdown
- Electromagnetic environmental risks.

To reduce the electromagnetic environment risks, installation rules and wiring must be respected.

For more information on EMC, refer to the *Electrical Installation Guide* chapter *ElectroMagnetic Compatibility* (*Wiki version available in English only on www.electrical-installation.org*).

Installation Rules

Installation rules that must be respected to enable the LTMR to operate correctly include:

- Installation rules for the components:
 - Association of the LTMR controller with the LTME expansion module.
 - Installation in a switchboard such as Okken, Blokset, or another type.
- LTMR controller wiring rules (*see page 20*):
 - Wiring of the power supply
 - Wiring of the I/Os: logic input wiring and logic output wiring
- Communication network wiring rules.

Installation Rules in a Switchboard

The installation of the LTMR controller in the withdrawable drawer of a switchboard presents constraints specific to the type of switchboard:

- For installation of the LTMR controller in a Schneider Electric Okken switchboard, refer to the *Okken Communications Cabling & Wiring Guide* (available on request).
- For installation of the LTMR controller in a Schneider Electric Blokset switchboard, refer to the *Blokset Communications Cabling & Wiring Guide* (available on request).
- For installation of the LTMR controller in other types of switchboard, follow the specific EMC instructions described in this guide and refer to the relative instructions specific to your type of switchboard.

Dimensions

Overview

This section presents the dimensions of the LTMR controller and the LTME expansion module, as well as the dimensions of the clearance zone around the controller and the expansion module. Dimensions are given in both millimeters and inches and apply to all LTMR and LTME models.

LTMR Controller Dimensions

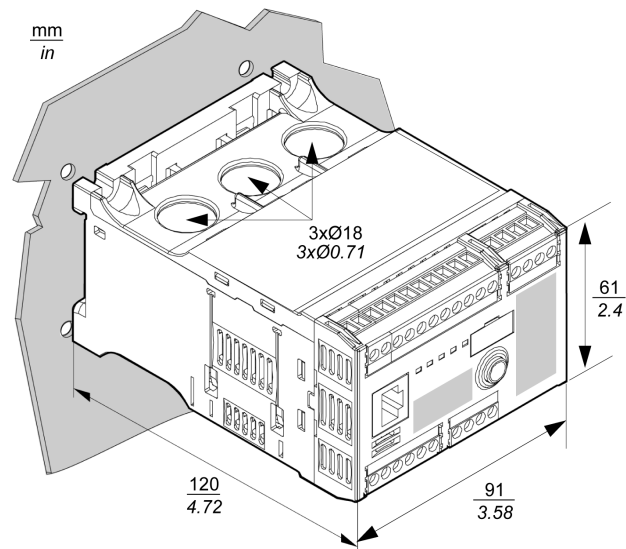

NOTE: The height of the controller may increase when using alternate wiring terminals.

LTME Expansion Module Dimensions

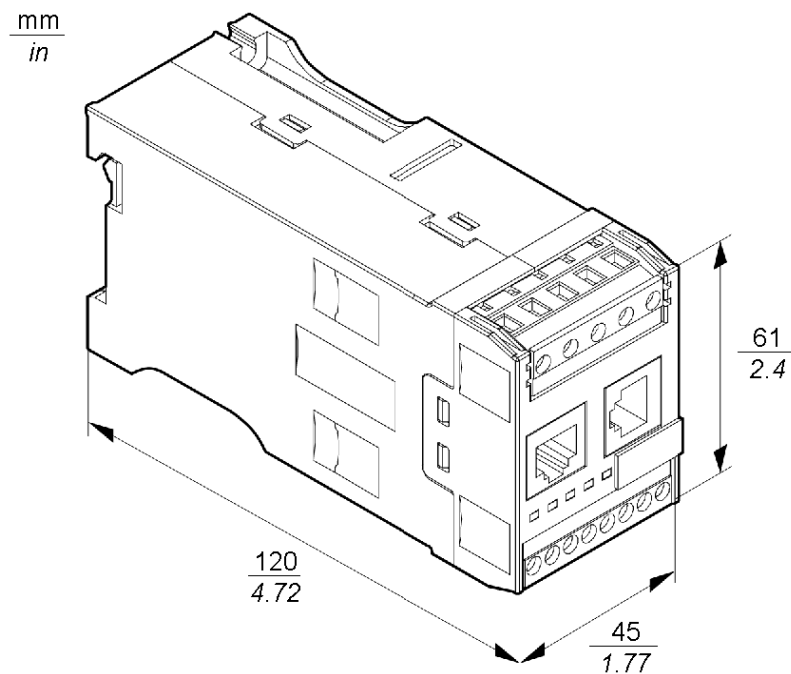

Clearance Zone Dimensions

For EMC (Electromagnetic Compatibility), it is recommended to mount a contactor at a distance of more than 5 cm (1.97 in) from the LTMR controller and LTME expansion module.

The maximum rated ambient temperature of the controller depends on the clearance zone dimensions. They are shown in the following table.

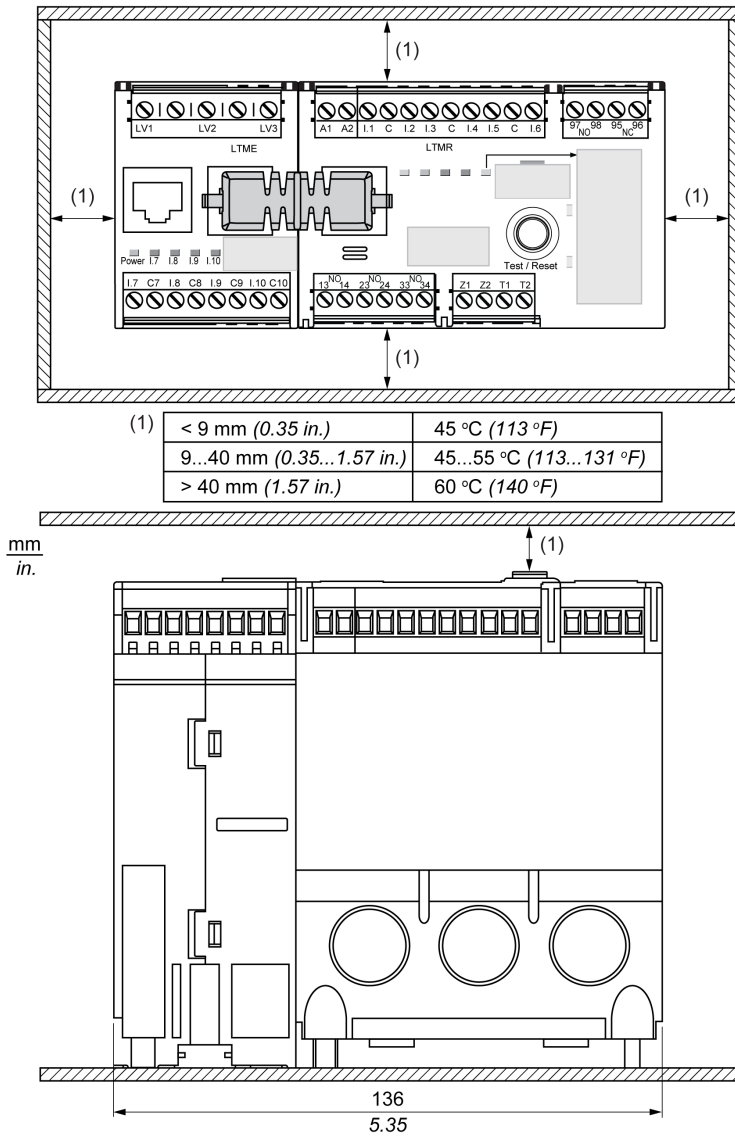

Assembly

Overview

This section describes how to assemble the LTMR controller and the LTME expansion module in a switchboard.

Connecting the LTMR Controller and the LTME Expansion Module

It is recommended to mount the LTMR controller and its LTME expansion module side by side with the LTME expansion module on the left side of the LTMR controller and connected by the LTMCC004 connecting jumper (1).

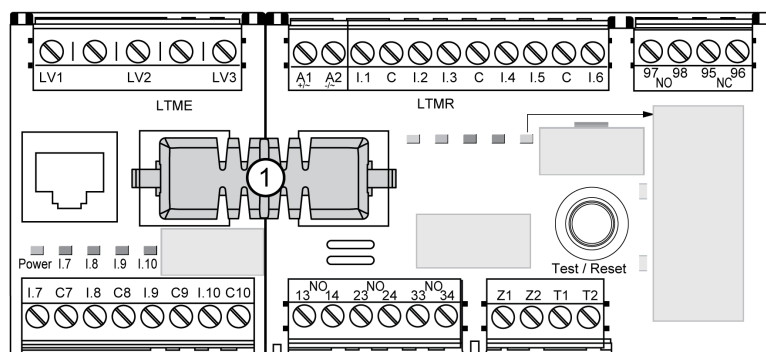

If it is not possible to mount the LTMR controller and its LTME expansion module side by side:

- Use only the shielded cables LTM9CEXP03 (2) or LTM9CEXP10 (3) cables to connect them.
- Ground the shielded cable.
- Separate the LTM9CEXP** connection cables from all other power or control cables to avoid EMC disturbance.

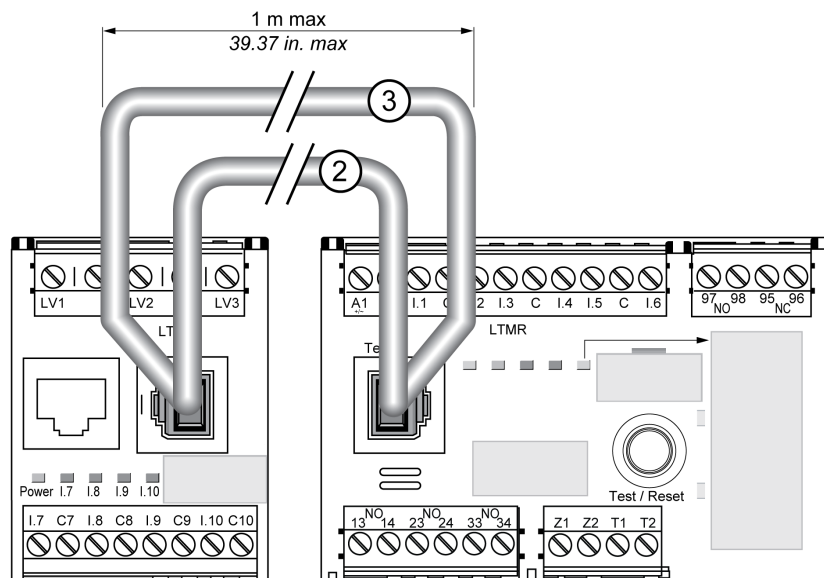

Example of Mounting in a Withdrawable Drawer of a Switchboard

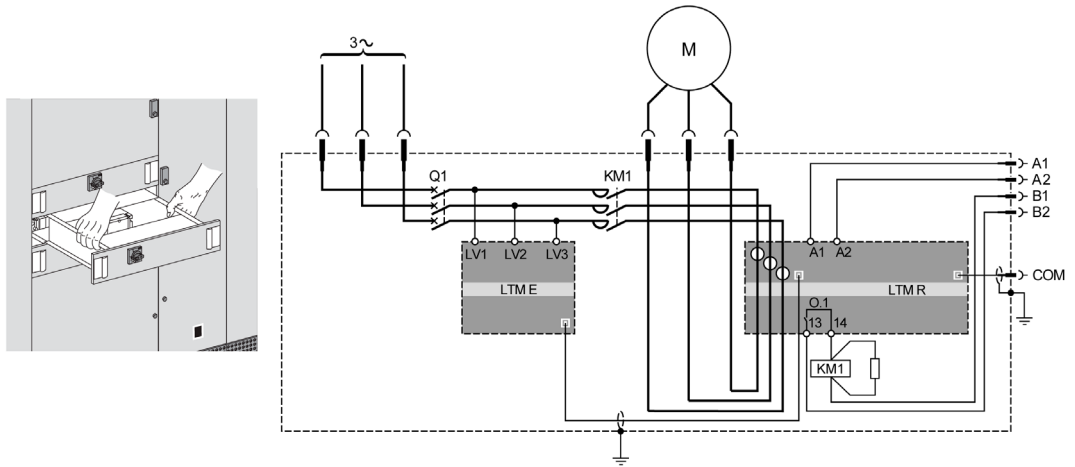

A1, A2 LTM R controller power supply
B1, B2 Power supply dedicated to logic outputs

Mounting

Overview

This section describes how to mount the LTMR controller and the LTME expansion module on a DIN rail, a solid mounting plate, or a pre-slotted mounting plate (known as a TE plate), such as a Telequick™ plate. It also describes the accessories needed for mounting, as well as how to remove each component.

Reminder: The LTMR controller and its LTME expansion module must be mounted side by side, with the LTME expansion module on the left side of the LTMR controller, connected by the LTMCC004 connecting jumper (*see page 15*).

Mounting on DIN Rails

You can mount the controller and the expansion module on a 35 mm (1.38 in.) DIN rail with a thickness of 1.35 mm (0.05 in.) and 0.75 mm (0.02 in.). When mounted, the controller mounting feet may not extend beyond the controller dimensions (*see page 13*). To mount the controller:

Step	Action
1	On the back of the controller are two DIN rail clips. Fit the top clip onto the DIN rail.
2	Push the controller in toward the DIN rail until the bottom clip catches. The controller clicks into place.

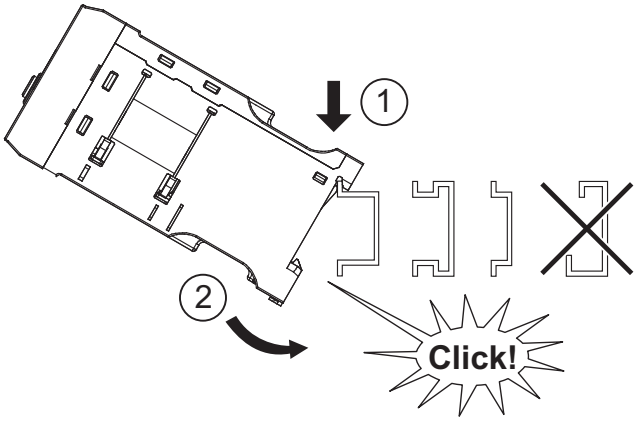

Removing from DIN Rails

To remove the controller from the DIN rail:

Step	Action
1	Using a screwdriver, pull down the white locking mechanism to release the controller.
2	Lift the controller away from the DIN rail.

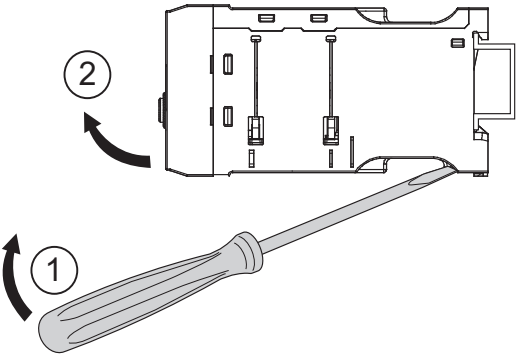

Mounting on a Solid Mounting Plate

You can mount the controller and the expansion module on a metal mounting plate using ST2.9 steel tapping screws: four for the controller and two for the expansion module. The thickness of the mounting plate must not exceed 7 mm (0.275 in.). When mounted, the controller mounting feet may extend beyond the controller dimensions (*see page 13*) by 8 mm (0.3 in.) in both directions. To mount the controller and the expansion module on a mounting plate:

Step	Action
1	Locate the four mounting holes at each corner of the controller and the two mounting holes on the expansion module.
2	Position the controller and expansion module on the mounting plate, making sure to leave enough space for the clearance zone (<i>see page 13</i>).
3	Insert each of the six tapping screws.
4	Use a screwdriver to tighten each screw and secure the controller and the expansion module in place. Torque to 1 N•m (8.8 lb-in).

The diagram illustrates the mounting process on a solid metal plate. It shows a perspective view of the controller and expansion module being secured to a grey metal plate. Six screws are shown being inserted into the mounting holes. Dimensions for the mounting holes are given in both millimeters and inches: 75.5 mm (2.97 in.) for the top holes, 14.5 mm (0.57 in.) for the middle holes, and 30.5 mm (1.2 in.) for the bottom holes. A vertical dimension of 52.5 mm (2.07 in.) is also shown. A screwdriver is shown with a torque specification of 1 N•m (8.8 lb-in). The screw specification is 6 x M4 x 20 (# 8 x 32).

Mounting on a TE Plate

You can mount the controller and the expansion module on a TE plate, such as Telequick, using six mounting clips (AF1 EA4). When mounted, the controller mounting feet may extend beyond the controller dimensions (*see page 13*) by 8 mm (0.3 in.) in both directions. To mount the controller on Telequick:

Step	Action
1	Attach the six mounting clips to Telequick, as shown in the diagram below. The rounded edge should face upwards for the top clips, and downwards for the bottom clips.
2	Position the controller and expansion module on the clips so that the holes in the clips and the holes in the controller and expansion module align. Insert the screws in the holes and turn them slightly.

Step	Action
3	<p>When the controller and expansion module are properly positioned, tighten first the bottom screws, then the top screws using a screwdriver. Torque to 1 N•m (8.8 lb-in).</p> <p>mm in</p> <p>75.5 2.97</p> <p>52.5 2.07</p> <p>1 2x</p> <p>2 2x</p> <p>3 4x</p> <p>4 4x</p> <p>5 2x</p> <p>6 2x</p>

Operating Position

You can mount the controller and the expansion module at an angle of up to 90 degrees perpendicular to the normal vertical mounting plane.

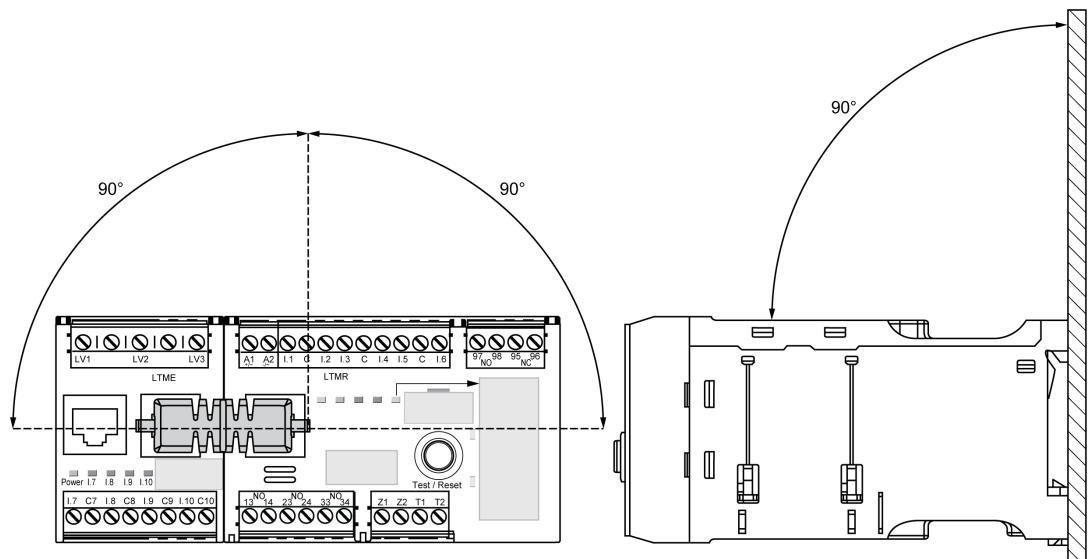

Wiring - Generalities

Overview

The wiring of each part of the LTMR controller and the LTME expansion module is detailed further with its specificities:

- Wiring the current transformers (*see page 25*).
- Wiring the ground fault current transformers (*see page 29*).
- Wiring the temperature sensors (*see page 31*).
- Wiring the power supply (*see page 32*).
- Wiring the logic inputs (*see page 34*).
- Wiring the logic outputs (*see page 38*).
- Wiring the voltage transformers on the LTME expansion module.

The wiring of the communication port depends on the communication protocol and is described in each communication guides.

Wiring Rules

The following wiring rules must be respected in order to reduce disturbance due to EMC on the behavior of the LTMR controller:

- Keep a distance as large as possible between the communication cable and the power and/or control cables (minimum 30 cm or 11.8 in.).
- Cross over different types of cables at right angles, if necessary.
- Do not bend or damage the cables. The minimum bending radius is 10 times the cable diameter.
- Avoid sharp angles of paths or passage of the cable.
- Use shielded cables to connect ground fault current transformers:
 - The cable shield must be connected to a protective ground at both ends.
 - The connection of the cable shield to the protective ground must be as short as possible.
 - Connect together all the shields, if necessary.
 - Perform the grounding of the shield with a collar.
- Add filters on contactor coils for all contactors and relays.
- Place the cable along the grounded plate around the withdrawable drawer.

For more information, refer to the *Electrical Installation Guide* (available in English only), chapter *ElectroMagnetic Compatibility (EMC)*.

Wiring Diagram Example: LTMR Controls a Three-phase Motor

The following diagram shows the wiring of the LTMR controller and its LTME expansion module used to control a three-phase motor in three-wire (impulse) independent mode:

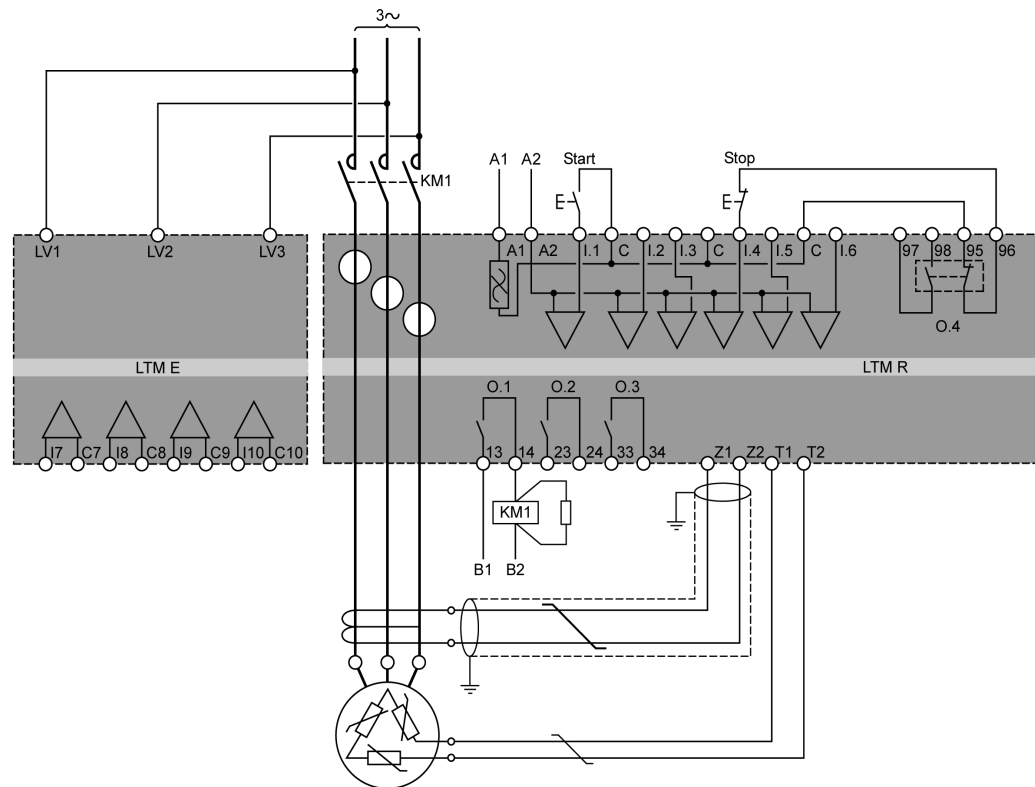

A1, A2 LTMR controller power supply
B1, B2 Power supply dedicated to logic outputs

Wiring Diagram Example: LTMR Controls a Single-phase Motor

The following diagram shows the wiring of the LTMR controller and its LTME expansion module used to control a single-phase motor in three-wire (impulse) independent mode:

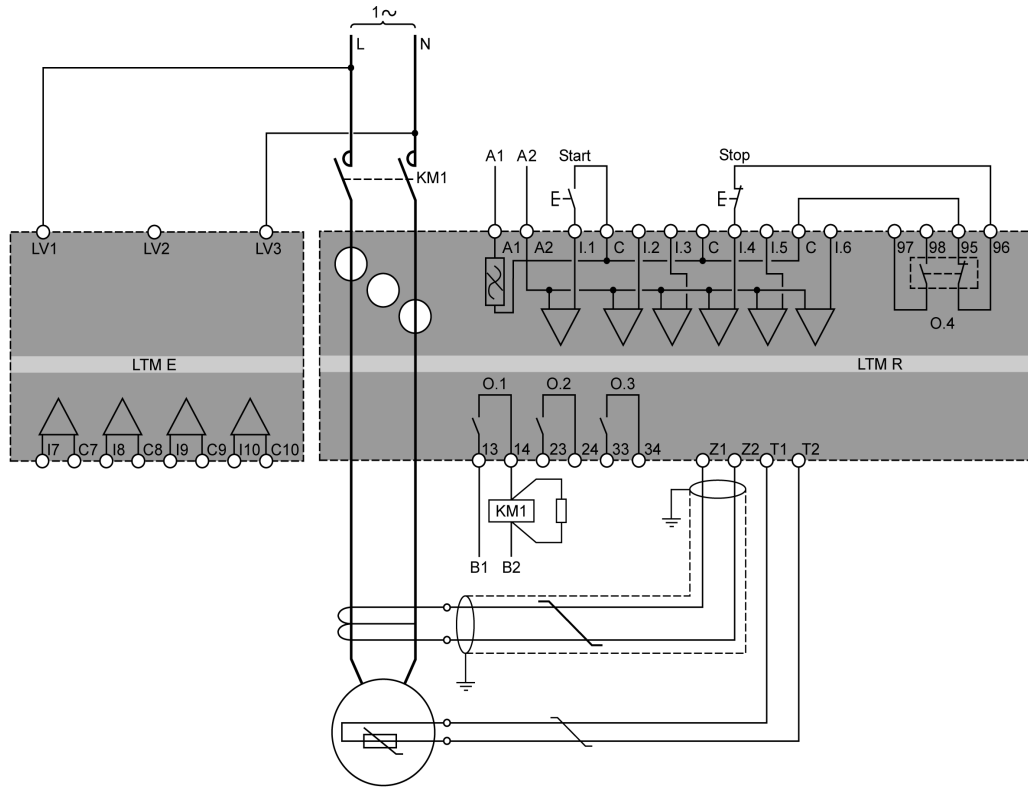

A1, A2 LTMR controller power supply
B1, B2 Power supply dedicated to logic outputs

LTMR Controller Plug-in Terminals and Pin Assignments

The LTMR controller has the following plug-in terminals and pin assignments:

Terminal Block	Pin	Description
Control voltage, logic input, and common source terminals	A1	Supply voltage input (+ / ~)
	A2	The negative of a power supply for DC models, or the grounded secondary of a control power transformer for AC models (- / ~)
	I.1	Logic input 1
	I.2	Logic input 2
	I.3	Logic input 3
	I.4	Logic input 4
	I.5	Logic input 5
	I.6	Logic input 6
O.4 Logic output terminals	C	Input common
	97-98	NO contact
O.1 to O.3 Logic output terminals	95-96	NC contact
	Note: The 97-98 contacts and the 95-96 contacts are on the same relay, so the open/closed status of one pair of contacts is always the opposite of the status of the other pair.	
	13-14	NO contact – logic output 1
	23-24	NO contact – logic output 2
	33-34	NO contact – logic output 3

The LTMR controller has the following plug-in terminals and pin assignments for different communication protocols:

Communication Protocol	Terminal Block	Pin	Description
Ethernet	Ground fault input and temperature sensor input	Z1–Z2	Connection for external ground fault current transformer
		T1–T2	Connection for motor temperature sensors
PROFIBUS DP	Ground fault input and temperature sensor input, and PLC terminals	Z1–Z2	Connection for external ground fault current transformer
		T1–T2	Connection for embedded motor temperature sensing elements
		S	PROFIBUS DP shield or FE pin
		A	Receive/transmit data-N pin; A-line
		B	Receive/transmit data-P pin; B-line
		DGND	Data ground pin
		VP	Power supply pin)
CANopen	Ground fault input, and temperature sensor input, and PLC terminals	Z1–Z2	Connection for external ground fault current transformer
		T1–T2	Connection for embedded motor temperature sensing elements
		V-	CANopen common pin
		CAN.L	CAN.L pin (dominant low)
		S	CANopen shield pin
		CAN.H	CAN.H pin (dominant high)
		V+	CANopen external power supply)
DeviceNet	Ground fault input and temperature sensor input, and PLC terminals	Z1–Z2	Connection for external ground fault current transformer
		T1–T2	Connection for embedded motor temperature sensing elements
		V-	DeviceNet common pin
		CAN.L	DeviceNet CAN.L pin (dominant low)
		S	DeviceNet shield pin
		CAN.H	DeviceNet CAN.H pin (dominant high)
		V+	DeviceNet external power supply pin

LTME Expansion Module Plug-in Terminals and Pin Assignments

The LTME expansion module has the following plug-in terminals and pin assignments:

Terminal block	Pin	Description
Voltage inputs	LV1	Phase 1 input voltage
	LV2	Phase 2 input voltage
	LV3	Phase 3 input voltage
Logic inputs and common terminals	I.7	Logic input 7
	C7	Common for I.7
	I.8	Logic input I.8
	C8	Common for I.8
	I.9	Logic input I.9
	C9	Common for I.9
	I.10	Logic input I.10
	C10	Common for I.10

Terminal Wiring Characteristics

Both the LTMR controller and LTME expansion module terminals have the same characteristics.

Terminals have an insulation rating of 320 Vac.

The following table describes the characteristics of cables that may be used to wire the terminals:

Cable Type	No. of Conductors	Conductor Section	
		mm ²	AWG
Flexible (stranded) cable	Single conductor	0.2...2.5	24...14
	Two conductors	0.2...1.5	24...16
Solid cable	Single conductor	0.2...2.5	24...14
	Two conductors	0.2...1.0	24...18
Flexible (stranded) cable with insulated cable ends	Single conductor	0.25...2.5	24...14
	Two conductors	0.5...1.5	20...16
Flexible (stranded) cable with non-insulated cable ends	Single conductor	0.25...2.5	24...14
	Two conductors	0.2...1.0	24...18

The following table describes the characteristics of the terminals:

Pitch	5.08 mm	0.2 in.
Tightening torque	0.5 to 0.6 N•m	5 lb-in
Flat screwdriver	3 mm	0.10 in.

Wiring - Current Transformers (CTs)

Overview

The LTMR controller has three CT windows through which you can route motor leads to contactor load connections.

The CT windows enable you to wire the controller in four different ways, depending on the voltage and controller model used:

- Internal CT wiring through the windows
- Internal CT wiring using multiple passes
- External Load CT wiring

This section describes each of these options.

Internal CT Wiring Through the Windows

The following diagrams show typical wiring using the CT windows for either three-phase or single-phase motors:

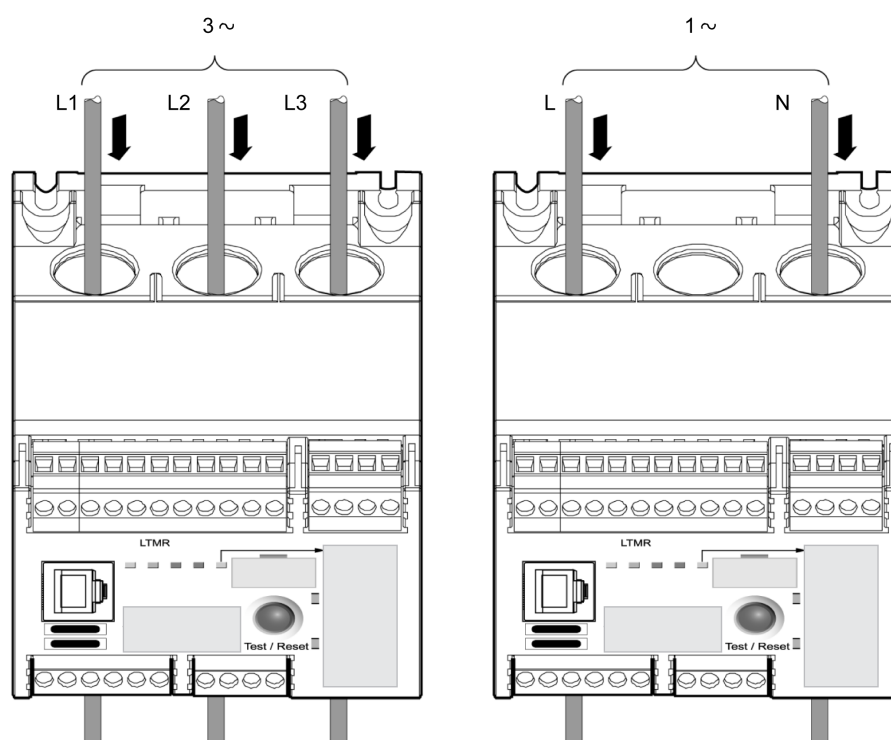

Internal CT Wiring Using Multiple Passes

The controller can physically support up to a maximum of five passes of 2.5 mm² (14 AWG) wire through the CT windows. There are three looping windows located under the CT windows that physically support up to a maximum of four wire loops.

Set the parameter Load CT Multiple Passes to account for the number of times the motor wires pass through the CT window in order to display the correct current readings. For more information, refer to Load Current Transformer settings ([see page 70](#)).

The following diagram shows typical wiring using two passes (one wire loop):

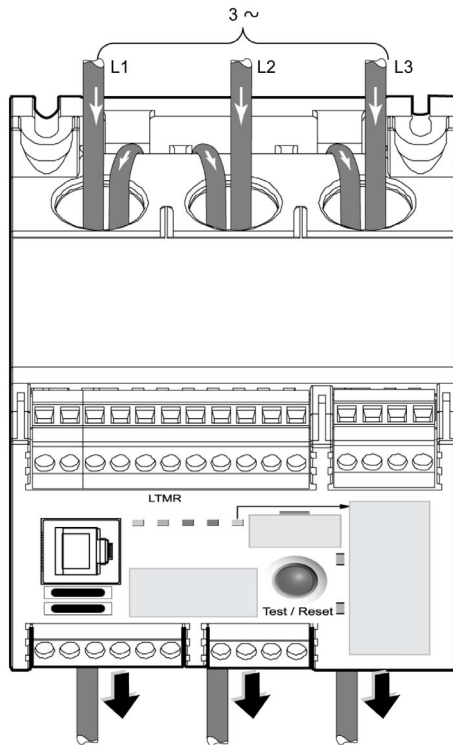

Multiply the current by the number of times that the motor wires pass through the CT windows to determine the amount of current passing through the internal current sensors.

Adding multiple passes allows to:

- Increase the current sensed by the internal current sensors to a level that the controller can properly detect, or
- Provide a more accurate reading by the internal current sensors.

We recommend that you select a controller with an FLC value range that includes the motor FLC. However, if the motor FLC is less than the FLC range of the controller, multiple passes can increase the current level sensed by the internal current sensors to one that the controller can detect.

For example, if using a controller with an FLC range of 5 to 100 A, and the motor FLC is 3 A, the controller cannot properly sense the current. In this case, if you pass the power wiring through the internal current sensors of the controller 2 times, the internal current sensors of the controller sense 6 A (2 passes x 3 A), a current level that falls within the FLC range of the controller.

For more information about controller types, refer to the *TeSys T LTMR Motor Management Controller User Guide*.

External Load CT Wiring

The controller can accept 5 A and 1 A secondary signals from external current transformers. The recommended controller model for these currents is the 0.4-8 A model. Use multiple passes through the controller CT windows, if required.

External CTs are specified with a transformation ratio. The ratio of the external CT is the ratio of the motor input current to the CT output current.

To enable the controller to adjust the FLC range and display the actual line current, set the following parameters:

- Load CT Primary (the first number of the CT ratio)
- Load CT Secondary (the second number of the CT ratio)
- Load CT Multiple Passes (the number of times the CT output wires pass through the controller’s internal CT windows.)

For more information, refer to Load Current Transformer settings (*see page 70*).

The following diagram shows wiring using external CTs:

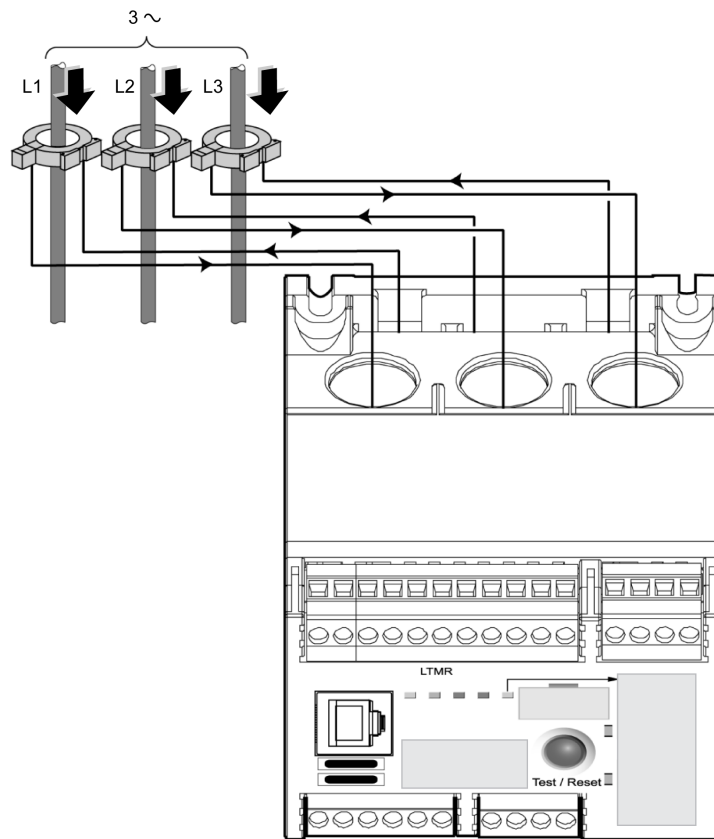

For a description of external CT characteristics, refer to the *TeSys T L TMR Motor Management Controller User Guide*.

CT Wiring in Presence of Variable Speed Drive

When the motor is controlled by a variable speed drive (VSD):

- The current transformers (external or internal) must be mounted upstream of the variable speed drive, and not between the variable speed drive and the motor. The CTs cannot be used between the drive outputs and the motor because the drive can output fundamental frequencies outside the 47-63 Hz range.
- Chokes must be mounted on the three phases, between the current transformers (external or internal) and the variable speed drive, to minimize the soft start harmonics current and the voltage disturbances generated by the variable speed drive.

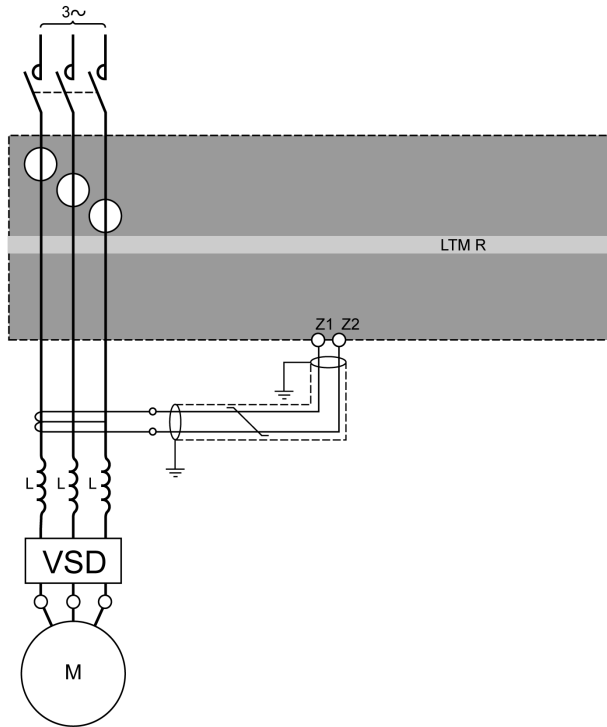

Wiring - Ground Fault Current Transformers

Ground Fault Current Transformer Installation

The following diagram shows a typical LTMR controller installation using a ground fault current transformer (GFCT):

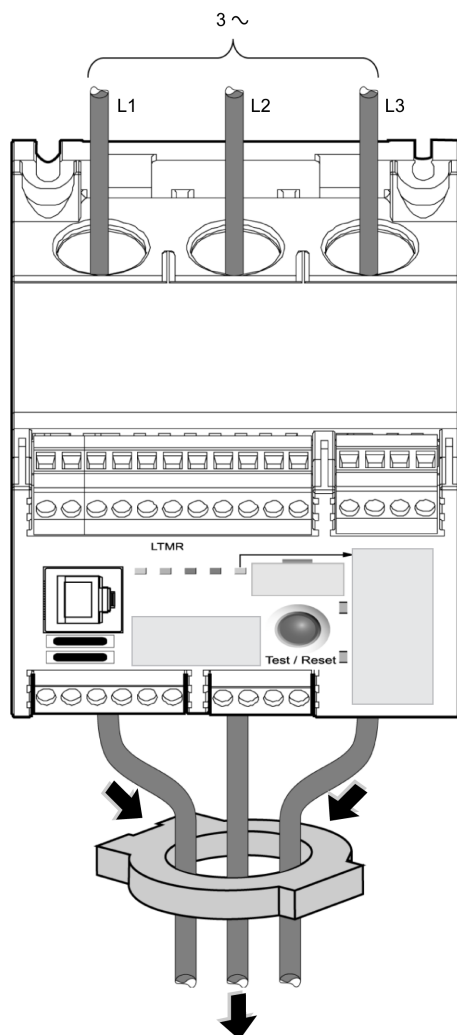

GFCTs are specified with a transformation ratio. The ratio of the GFCT is the ratio of the ground fault current sensed to the current which it outputs.

To enable the controller to correctly measure the actual ground fault current flowing in the circuit, set the following parameters:

- Ground CT Primary (the first number of the GFCT ratio)
- Ground CT Secondary (the second number of the GFCT ratio)

For a description of GFCT characteristics, refer to the *TeSys T LTMR Motor Management Controller User Guide*.

Ground Fault Current Transformer Wiring

The external ground fault current transformer (GFCT) must be connected to the LTMR controller terminals Z1 and Z2 using a shielded twisted pair cable. The shield must be connected to the earth at both ends by the shortest possible connections.

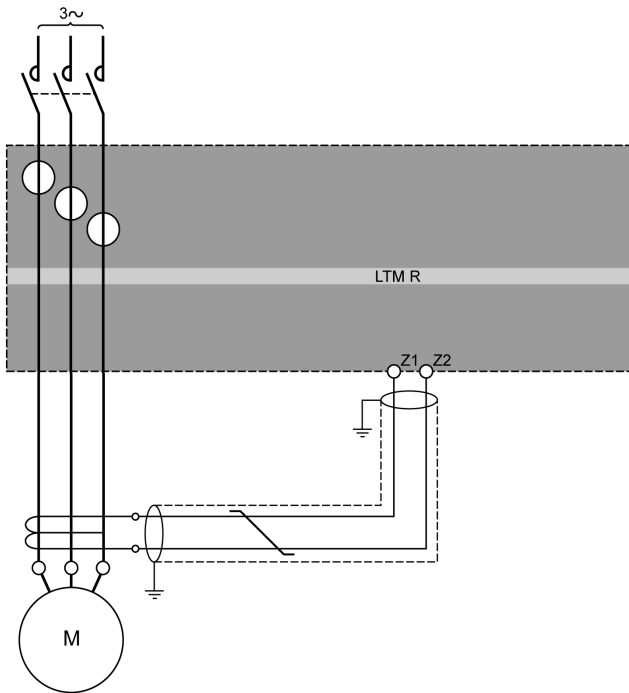

Wiring - Temperature Sensors

Temperature Sensors

The LTMR controller has two terminals dedicated to motor temperature sensing protection: T1 and T2. These terminals return the temperature value measured by resistance temperature detectors (RTDs).

One of the following types of motor temperature sensor can be used:

- PTC Binary
- PT100
- PTC Analog
- NTC Analog

For more information on temperature sensors, refer to the *TeSys T LTMR Motor Management Controller User Guide*.

Temperature Sensor Wiring

The following table shows the maximum wire lengths for temperature sensor elements:

Wire Size	0.5 mm ² (AWG 20)	0.75 mm ² (AWG 18)	1.5 mm ² (AWG 16)	2.5 mm ² (AWG 14)
Maximum Wire Length	220 m (656 ft)	300 m (985 ft)	400 m (1312 ft)	600 m (1970 ft)

Use unshielded twisted pair cable to connect the controller to the temperature sensor.

For the controller to accurately measure the resistance of the temperature-sensing element, you must measure the resistance of the twisted-pair and add it to the desired resistance for protection. This compensates for the lead resistance.

The following diagram shows the wiring of the LTMR controller and the temperature sensor of a single-phase motor:

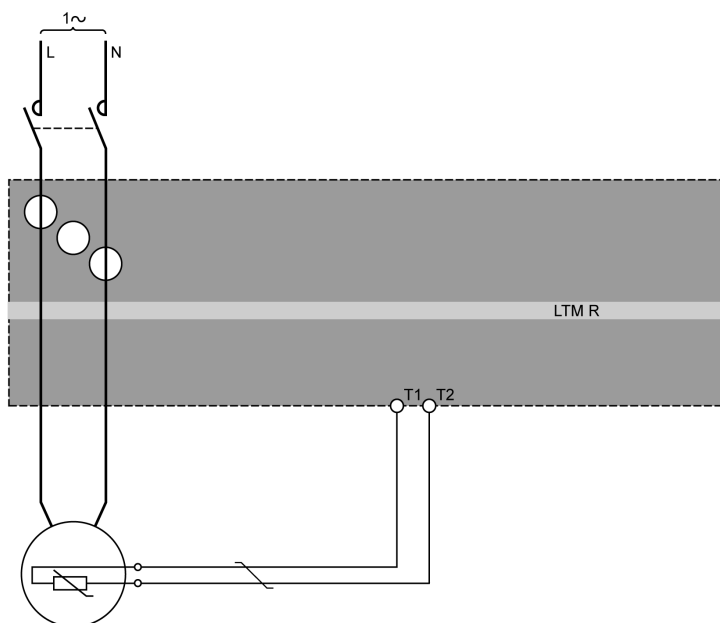

For more information about wiring, see *Wiring Generalities (see page 20)*.

Wiring - Power Supply

Overview

The LTMR controller supply voltage can be:

- 24 Vdc, or
- 100...240 Vac

The following table presents LTMR controller and LTME expansion module association rules:

	LTMR...BD (VDC)	LTMR...FM (VAC)
LTME...BD (VDC)	X	X
LTME...FM (VAC)	–	X
X Association allowed		
– Association not allowed		

DC Power Supply

A dedicated 24 Vdc power supply is necessary to supply:

- One or several LTMR controllers including the logic inputs of the LTMR controller(s).
- The logic inputs of the LTME expansion module(s).

An additional specific 24 Vdc power supply is necessary to supply:

- The LTMR controller logic outputs.
- Other devices.

The LTMR controller DC power supply must have the following characteristics:

- AC/DC converter.
- Galvanic isolation input AC / output DC: 4 kVac minimum at 50 Hz.
- Input voltage: 240 Vac (+15% / -20%).
- Output voltage: 24 Vdc (+/-10%).

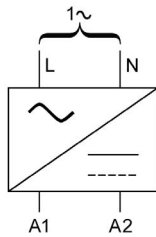

The following Schneider Electric ABL8RPS24... power supplies are recommended:

Reference Number	Input Voltage	Output Voltage/Current	Maximum Number of LTMR Controllers Supplied
ABL8RPS24100	200...500 Vac	24 Vdc / 10 A	24
ABL8RPS24050	200...500 Vac	24 Vdc / 5 A	12
ABL8RPS24030	200...500 Vac	24 Vdc / 3 A	8

AC Power Supply

A dedicated AC/AC power supply or UPS is necessary to supply:

- One or several LTMR controllers including the logic inputs of the LTMR controller(s).
- The logic inputs of the LTME expansion module(s).

An additional specific AC or DC power supply is necessary to supply:

- The LTMR controller logic outputs.
- Other devices.

The LTMR controller AC power supply or UPS must have the following characteristics:

- Isolation transformer
- Output voltage: 115 or 230 Vac (+15% / -20%)
 - 115 Vac output voltage is recommended.
 - With 230 Vac output voltage, an additional LTM9F external filter may be necessary.
- Power according to the number of LTMR controllers (several AC supplies are recommended).
- UPS is mandatory if voltage is unstable and does not follow EN 50160.

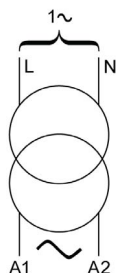

Power Supply Daisy Chaining

When the same power supply (AC or DC) is used to supply several LTMR controllers, it is recommended to close the loop:

- To avoid power off,
- To reduce voltage drop due to long cables.

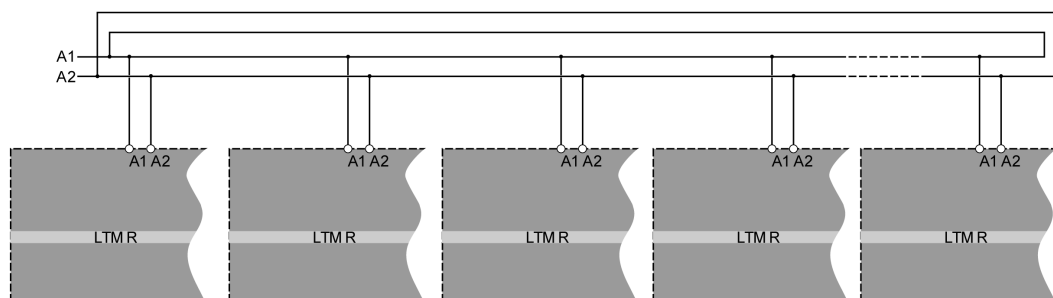

Wiring - Logic Inputs

Overview

10 logic inputs maximum are provided:

- Six logic inputs on the LTMR controller, internally powered by the LTMR.
- Four logic inputs on the LTME expansion module, independently powered.

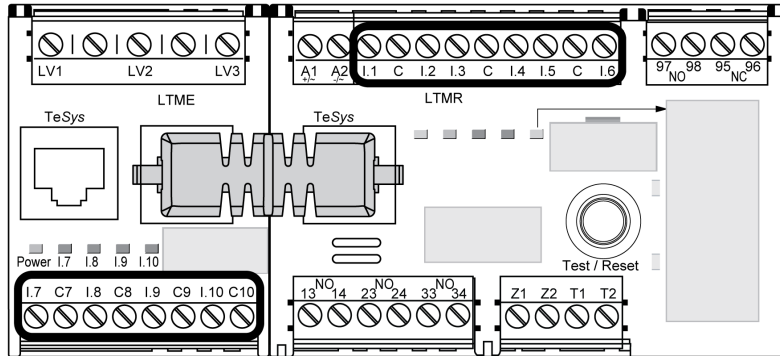

Logic Inputs of the LTMR Controller

The controller LTMR has six logic inputs:

- Available via field wiring terminals I.1- I.6.
- Internally powered by the control voltage of the LTMR controller (the input voltage is the same voltage as the controller supply voltage.)
- Isolated from the inputs of the LTME expansion module.

The three Common (C) terminals of the LTMR controller are connected to the A1 control voltage via an internal filter, as shown in the wiring diagram examples ([see page 20](#)).

NOTICE

LOGIC INPUTS DESTRUCTION HAZARD

- Connect the LTMR controller's inputs using the three Common (C) terminals connected to the A1 control voltage via an internal filter.
- Do not connect the Common (C) terminal to the A1 or A2 control voltage inputs.

Failure to follow these instructions can result in equipment damage.

For more information, refer to the power supply wiring ([see page 32](#)) and the technical specifications of the LTMR controller in the *TeSys T LTMR Motor Management Controller User Guide*.

Logic Inputs of the LTME Expansion Module

The four logic inputs on the LTME expansion module (I.7 - I.10) are not powered by the control voltage of the LTMR controller.

For more information, refer to the technical specifications of the LTME expansion module in the *TeSys T LTMR Motor Management Controller User Guide* and to the power supply description ([see page 32](#)).

Controller AC Inputs Setting

The LTMR controller uses digital filters to obtain a correct AC signal on the inputs.

For more accurate results, this filter can be configured by the controller AC inputs setting register to set the voltage supply and activate the adaptive filtering internal feature.

Connection of the Logic Inputs

NOTICE

UNINTENDED EQUIPMENT OPERATION

- Install interposing relay for long distance inputs.
- Segregate control cable from power cable.
- Use dry contact on LTMR inputs.
- Respect the recommendations given in this chapter.

Failure to follow these instructions can result in unwanted motor stops.

Three types of connection are possible:

- Direct connection for all information on logic inputs coming from the switchboard.
- Connection via interposing relays for all information on logic inputs coming from outside of the switchboard and mainly connected with long lines.
Using interposing relays reduces EMC disturbance effects on the LTMR controller and improves the reliability of the information.
- Connection without interposing relays for logic input on short distance.

For TeSys T inputs / outputs applications, only dry contacts free of potential can be used. Otherwise, current could be supplied to sensor or device and affect the input / output state.

Inductive Interference

For parallel cable runs above 100 m (328 ft) with close proximity between control and power, an induced voltage can be generated and cause the relay to remain blocked. It is highly recommended to separate control and power with 50 cm (1.64 ft) space or use separation plate. To limit the induced voltage in AC, it is possible to add a clamping resistor in parallel of the interposing relay.

Maximum Distance Without Interposing Relay

The maximum distance allowed without interposing relay is addressed below:

Wire Size	1 mm ² (AWG 18)	1.5 mm ² (AWG 16)	2 mm ² (AWG 14)	2.5 mm ² (AWG 14)
Maximum distance for wires	210 m (689 ft)	182 m (597 ft)	163 m (535 ft)	149 m (489 ft)

However, due to variability of installations it is highly recommended to use interposing relays for control cable lengths longer than 100 m (328 ft).

Recommended Interposing Relay

Interposing relays must have the following characteristics:

- Electromechanical relay with 2.5 kVac isolation minimum.
- Self-cleaning or low level contact ($I < 5$ mA).
- Installed in the switchboard as close as possible to the LTMR controller.
- AC or DC control circuit voltage, supplied by separate power supply (not supplied by the same power supply as the LTMR controller to respect the galvanic isolation).

In case of long distances between the process and the LTMR controller, interposing relays with DC control circuit voltage are recommended.

The protection module is mandatory on the interposing relays in order to suppress the surge.

The following Schneider Electric RSB1 interposing relays are recommended:

Reference Number	Control Circuit Voltage	Protection Module
RSB1A120•D	6, 12, 24, 48, 60, 110 Vdc	Diode RZM040W
RSB1A120•7	24, 48 Vac	RC circuit RZM041BN7
RSB1A120•7	120, 220, 230, 240 Vac	RC circuit RZM041FU7

Use of DC Interposing Relays

The DC interposing relays are recommended because long wires distances can be used to command the relay.

DC RSB1 relay voltage	24 Vdc	48 Vdc	110 Vdc
Maximum distance for wires in parallel without metallic screening	3,000 m (10,000 ft)	3,000 m (10,000 ft)	3,000 m (10,000 ft)
Maximum distance for wires in parallel with metallic screening	3,000 m (10,000 ft)	3,000 m (10,000 ft)	3,000 m (10,000 ft)

The following diagram shows an example when using DC interposing relays:

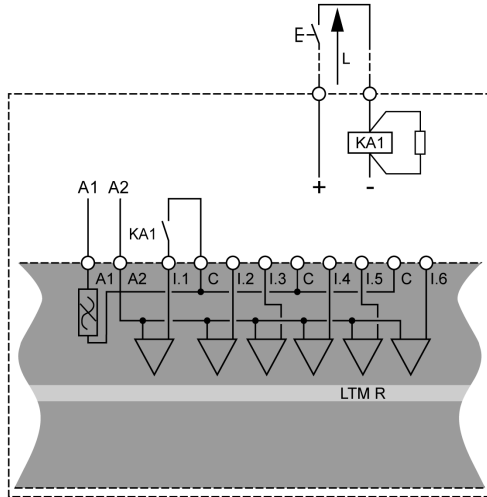

Use of AC Interposing Relays

The use of an AC interposing relay is allowed only on short distances if an AC voltage is mandatory.

AC RSB1 relay voltage	24 Vac	48 Vac	120 Vac	230/240 Vac
Maximum distance for wires in parallel without metallic screening	3,000 m (10,000 ft)	1,650 m (5,500 ft)	170 m (550 ft)	50 m (165 ft)
Maximum distance for wires in parallel with metallic screening	2,620 m (8,600 ft)	930 m (3,000 ft)	96 m (315 ft)	30 m (100 ft)

The following diagram shows an example when using AC interposing relays:

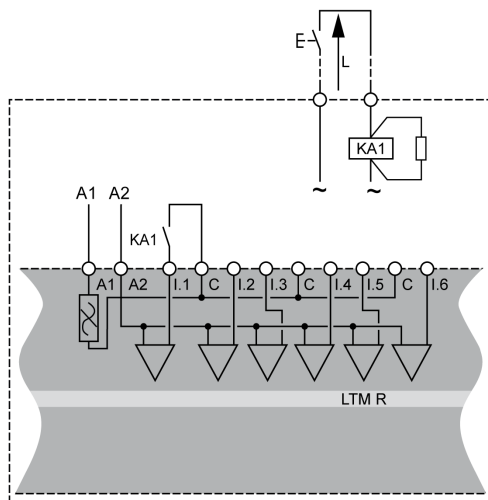

Use of AC Interposing Relays with a Rectifier

The use of AC interposing relay with a rectifier is recommended on long distances if an AC voltage is mandatory.

Add a rectifier composed of 1 A / 1,000 V diodes to command an AC interposing relay. In this way, rectified AC current flows in the control cable when the switch in the continuous part is closed.

Relay drop out time increases with the stray capacitance (long cable length) because the capacitance reduces the inductive behavior of the coil. The equivalent component tends to be a resistor increasing the drop-out time. Moreover, the more the voltage is high the more the phenomenon is important.

AC RSB1 relay voltage	24 Vac	48 Vac	120 Vac	230/240 Vac
Maximum distance for wires in parallel without metallic screening	3,000 m (10,000 ft)	3,000 m (10,000 ft)	3,000 m (10,000 ft)	3,000 m (10,000 ft)
Maximum distance for wires in parallel with metallic screening	3,000 m (10,000 ft)	3,000 m (10,000 ft)	3,000 m (10,000 ft)	3,000 m (10,000 ft)

The following diagram shows an example when using AC interposing relays with a rectifier:

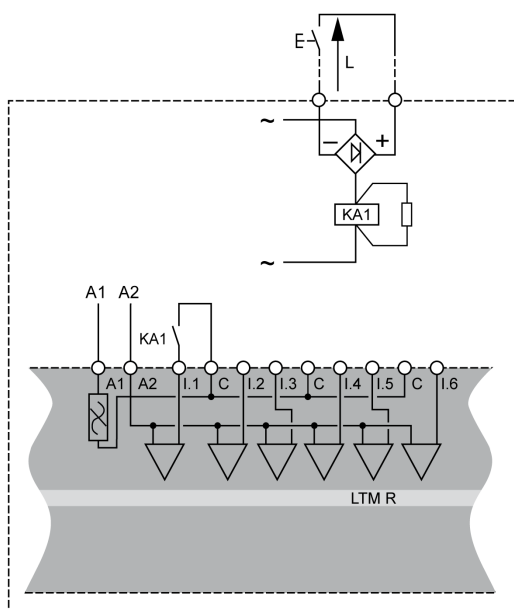

Wiring - Logic Outputs

Overview

The four logic outputs of the LTMR controller are relay outputs. The relay outputs command the motor managed by the LTMR controller.

The four relay outputs on the LTMR controller are:

- Three single pole / single throw (SPST, NO) relay outputs
- One double pole / single throw (DPST, NC+NO) relay output

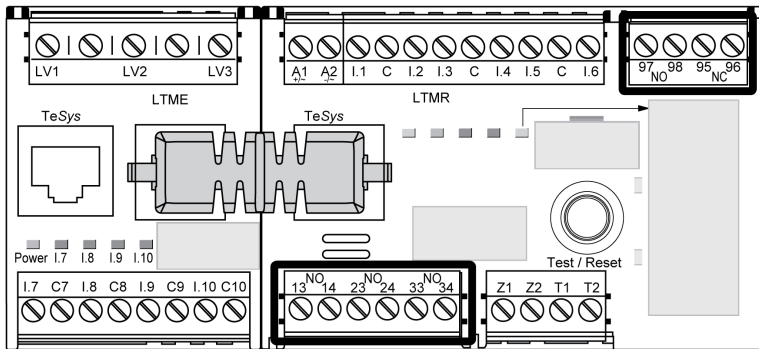

Output Interposing Relays

When an output commands a contactor, an interposing relay may be required depending of the coil voltage and the power required by the contactor used.

The following diagrams illustrate system wiring without and with the use of an interposing relay KA1:

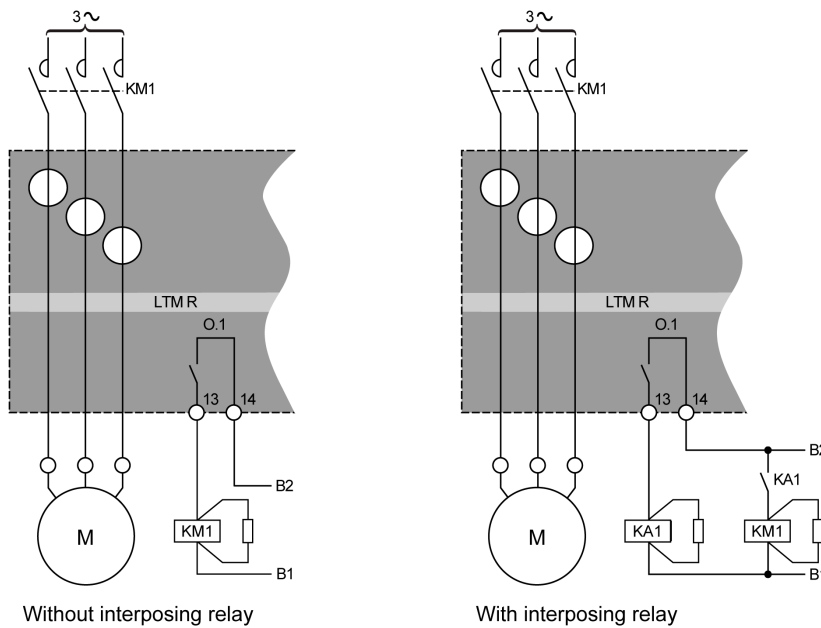

B1, B2 Power supply dedicated to logic outputs

The LTMR controller logic output characteristics are:

- Rated insulation voltage: 300 V
- AC rated thermal load: 250 Vac / 5 A
- DC rated thermal load: 30 Vdc / 5 A
- AC 15 rating: 480 VA, 500,000 operations, I_e max = 2 A
- DC 13 rating: 30 W, 500,000 operations, I_e max = 1.25 A

If the LTMR controller logic output is not able to control directly the contactor, an interposing relay is required.

The protection module is mandatory on the interposing relays in order to suppress the surge.

Recommended Contactors

The tables in the appendix, listing the references and characteristics of Schneider Electric contactors, specify whether an interposing relay is required or not. Refer to the Recommended Contactors in the *TeSys T LTMR Motor Management Controller User Guide*.

Connecting to an HMI Device

Overview

This section describes how to connect the LTMR controller to an HMI device, such as a Magelis XBT or a TeSys T LTMCU, or to a PC running SoMove with the TeSys T DTM. The HMI device must be connected to the RJ45 port on the LTMR controller, or to the HMI interface port (RJ45) on the LTME expansion module.

The Magelis XBT HMI device must be powered separately. Connect it to a controller in one-to-many mode.

Wiring Rules

The wiring rules must be respected in order to reduce disturbance on the behavior of the LTMR controller due to EMC.

The exhaustive list of wiring rules is described in the general recommendations (*see page 20*).

<i>NOTICE</i>
UNINTENDED EQUIPMENT OPERATION
Use Schneider Electric standard cables.
Failure to follow these instructions can result in equipment damage.

Connecting to a Magelis XBT HMI Device in One-to-Many Mode

The diagram below shows a one-to-many connection from the Magelis XBTN410 HMI to up to eight controllers, with and without the LTME expansion module:

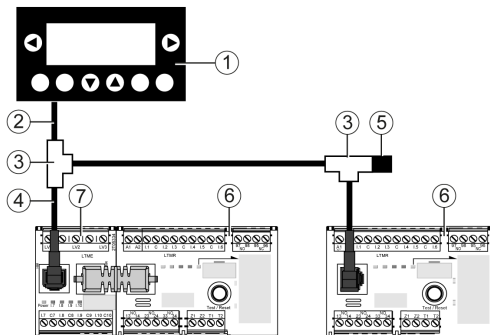

- 1 Magelis XBTN410 HMI device
- 2 Magelis connecting cable XBTZ938
- 3 T-junction boxes VW3 A8 306 TF••
- 4 Shielded cable with two RJ45 connectors VW3 A8 306 R••
- 5 Line terminator VW3 A8 306 R
- 6 LTMR controller
- 7 LTME expansion module

Connecting to a TeSys T LTMCU HMI Device

The diagrams below show the TeSys T LTMCU HMI device connected to the LTMR controller, without and with the LTME expansion module:

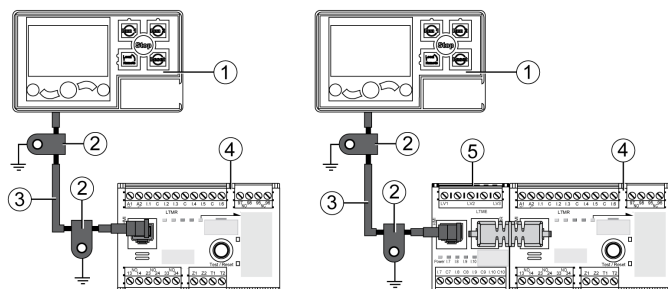

- 1 LTMCU Control Operator Unit
- 2 Grounding collar
- 3 LTM9CU HMI device connection cable
- 4 LTMR controller
- 5 LTME expansion module

Connecting to a Generic HMI Device

Connect the LTMR controller and the expansion module to an HMI device of your choice, using a shielded cable for Modbus bus, reference TSX CSA ...

The RJ45 port pinouts to connect to the HMI port of the LTMR controller or the LTME expansion module is:

Front view

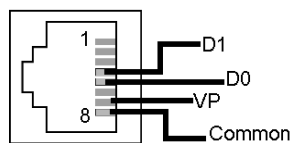

The RJ45 wiring layout is:

Pin No.	Signal	Description
1	Reserved	Do not connect
2	Reserved	Do not connect
3	–	Not connected
4	D1 or D(B)	Communication between HMI and LTMR controller
5	D0 or D(A)	Communication between HMI and LTMR controller
6	Reserved	Do not connect
7	VP	+7 Vdc (100 mA) power supply provided by the LTMR controller
8	Common	Signal and power supply common

Connecting to a PC Running SoMove with the TeSys T DTM in One-to-One Mode Using the HMI Port

The diagrams below show a one-to-one connection from a PC running SoMove with the TeSys T DTM to the HMI port of the LTMR controller, with and without the LTME expansion module and the LTMCU:

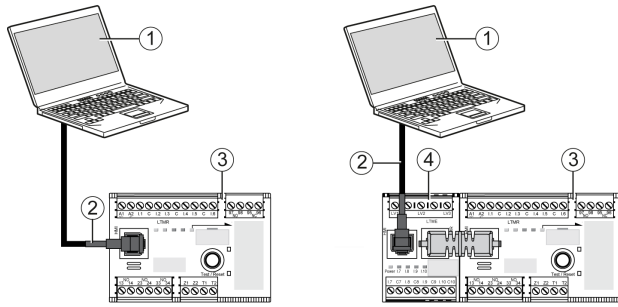

- 1 PC running SoMove with the TeSys T DTM
- 2 TCSMCNAM3M0 Modbus USB/RJ45 cable
- 3 LTMR controller
- 4 LTME expansion module

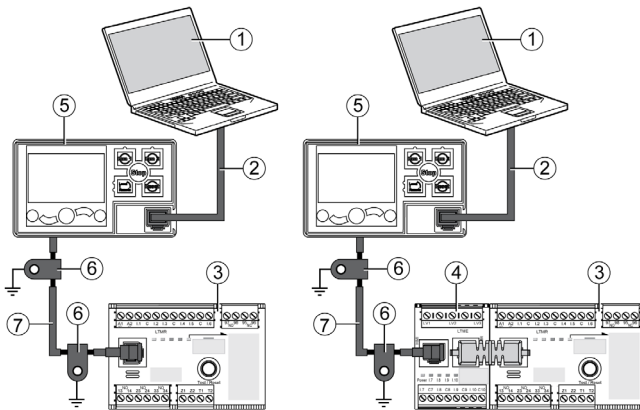

- 1 PC running SoMove with the TeSys T DTM
- 2 Cable kit TCSMCNAM3M002P
- 3 LTMR controller
- 4 LTME expansion module
- 5 LTMCU Control Operator Unit
- 6 Grounding collar
- 7 LTM9CU•• HMI device connection cable

Connecting to a PC Running SoMove with the TeSys T DTM in One-to-One Mode Using One LTMR Ethernet Network Port

The diagrams below show a one-to-one connection from a PC running SoMove with the TeSys T DTM to one of the two network ports of the LTMR Ethernet controller, with and without the LTME expansion module and the LTMCU:

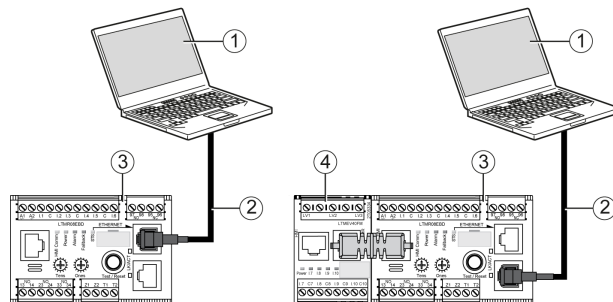

- 1 PC running SoMove with the TeSys T DTM
- 2 Cat 5 shielded or unshielded twisted pair Ethernet cable
- 3 LTMR Ethernet controller
- 4 LTME expansion module

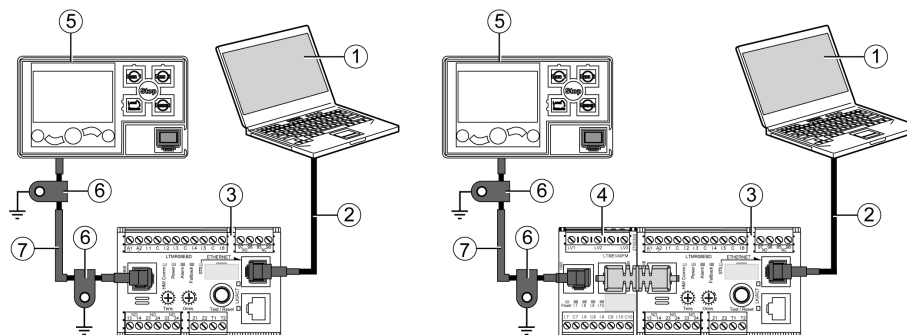

- 1 PC running SoMove with the TeSys T DTM
- 2 Cat 5 shielded or unshielded twisted pair Ethernet cable
- 3 LTMR Ethernet controller
- 4 LTME expansion module
- 5 LTMCU Control Operator Unit
- 6 Grounding collar
- 7 LTM9CU• HMI device connection cable

When the LTMCU is connected to a PC, the LTMCU becomes passive and cannot be used to visualize information.

Connecting to a PC Running SoMove with the TeSys T DTM in One-to-Many Mode

The diagram below shows a one-to-many connection from a PC running SoMove with the TeSys T DTM to up to eight controllers (with or without the LTME expansion module):

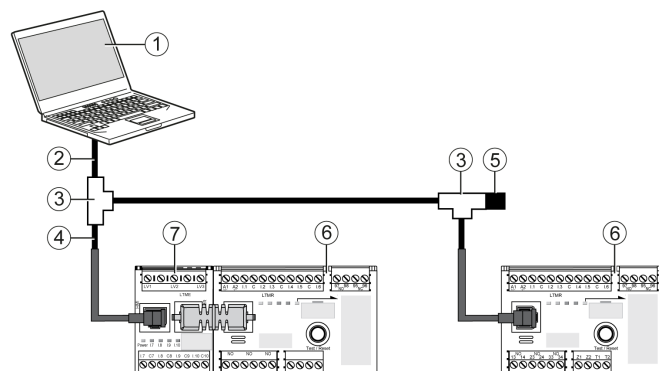

- 1 PC running SoMove with the TeSys T DTM
- 2 Cable kit TCSMCNAM3M002P
- 3 T-junction boxes VW3 A8 306 TF••, including a shielded cable with two RJ45 connectors
- 4 Shielded cable with 2 RJ45 connectors VW3 A8 306 R••
- 5 Line terminator VW3 A8 306 R
- 6 LTMR controller
- 7 LTME expansion module

NOTE: For Modbus communication protocol, this connection requires to define different HMI communication addresses. The factory setting of the HMI port address is 1.

Connection Accessories

The following table lists connection accessories for the Magelis XBT and other HMI devices:

Designation	Description	Reference
T-junction boxes	Box with two RJ45 female connector for trunk cable and an integrated 0.3 m (1 ft) cable with one RJ45 male connector for tap-off	VW3 A8 306 TF03
	Box with two RJ45 female connector for trunk cable and an integrated 1 m (3.2 ft) cable with one RJ45 male connector for tap-off	VW3 A8 306 TF10
Line terminator for RJ45 connector	$R = 120 \Omega$	VW3 A8 306 R
Magelis connecting cable (Magelis XBTN410 only)	Length = 2.5 m (8.2 ft) 25 pts SUB-D connector to connect to Magelis® XBT	XBTZ938
Cable kit	Length = 2.5 m (8.2 ft) USB to RS 485 converter	TCSMCNAM3M002P
Communication cables	Length = 0.3 m (1 ft)	VW3 A8 306 R03
	Length = 1 m (3.2 ft)	VW3 A8 306 R10
	Length = 3 m (3.2 ft)	VW3 A8 306 R30
HMI device connection cable	Length = 1 m (3.2 ft)	LTM9CU10
	Length = 3 m (9.6 ft)	LTM9CU30

Chapter 3

Commissioning

Overview

This chapter provides an overview for commissioning the LTMR controller and the LTME expansion module.

What Is in This Chapter?

This chapter contains the following topics:

Topic	Page
Introduction	46
First Power-up	48
Required and Optional Parameters	50
FLC (Full Load Current) Settings	51
Verifying System Wiring	53
Verify Configuration	55

Introduction

Introduction

Commissioning must be performed after the physical installation of the LTMR controller, LTME expansion module and other hardware devices.

The commissioning process includes:

- Initialization of the installed devices, and
- Configuration of the LTMR controller parameters that are required for operation of the LTMR controller, LTME expansion module, and other system hardware

The person performing commissioning must be familiar with the system hardware, and how it will be installed and used in the application.

Hardware devices can include:

- Motor
- Voltage transformers
- External load current transformers
- Ground current transformers
- Communication network

The product specifications for these devices provide the required parameter information. You need to understand how the LTMR controller will be used to be able to configure the protection, monitoring, and control functions for the application.

For information about configuring protection and control parameters, refer to the *TeSys T LTMR Motor Management Controller User Guide*.

For information about the configuration of the communication network, refer to

- *TeSys T LTMR Ethernet Communication Guide*
- *TeSys T LTMR Modbus Communication Guide*
- *TeSys T LTMR PROFIBUS DP Communication Guide*
- *TeSys T LTMR CANopen Communication Guide*
- *TeSys T LTMR DeviceNet Communication Guide*

Initialization

The LTMR controller is ready to be initialized after the hardware installation is complete. To initialize the LTMR controller:

- Be sure the command to control the motor is off, then
- Turn on the LTMR controller

CAUTION

IMPROPER INITIALIZATION

Disconnect power to the motor before initializing the LTMR controller.

Failure to follow these instructions can result in injury or equipment damage.

Neither the LTMR controller nor the LTME expansion module require additional hardware configuration (for example, turning dials, or setting dip-switches) to be initialized. When powered up for the first time, the LTMR controller enters an initial state and is ready for commissioning.

Configuration Tools

Identify the configuration control source—and the configuration tool—before configuring parameters. The LTMR controller and LTME expansion module can be configured locally using an HMI device or remotely via the network connection.

The LTMR controller can be commissioned using:

- An LTMCU control operator unit,
- A PC running SoMove with the TeSys T DTM,
- A PLC connected to the LTMR controller's network port.

The following parameters identify the configuration control source:

Parameter	Enables Use of This Tool	Factory Setting
Config Via HMI Keypad Enable	TeSys T LTMCU control operator unit	Enabled
Config Via HMI Engineering Tool Enable	PC running SoMove with the TeSys T DTM	Enabled
Config Via Network Port Enable	the network port (PLC or PC running SoMove with TeSys T DTM)	Enabled

This chapter describes commissioning performed using the LTMCU control operator unit, or SoMove with the TeSys T DTM.

Commissioning Process

The commissioning process remains the same, regardless which configuration tool you select. This process includes the following stages:

Stage	Description
First power-up	The LTMR controller initializes, and is ready for parameter configuration.
Configuring required settings	Configure these parameters to move the LTMR controller out of its initialization state. The LTMR controller is ready for operations.
Configuring optional settings	Configure these parameters to support the LTMR controller functions required by the application.
Verifying hardware	Check hardware wiring.
Verifying the configuration	Confirm accurate parameter settings.

First Power-up

Overview

First power-up describes the first time power is cycled to:

- A new LTMR controller, or
- An LTMR controller that has been previously commissioned, but whose parameter settings have been restored to the factory settings, either as a result of:
 - Execution of the Clear All Command, or
 - A firmware upgrade

On first power-up, the LTMR controller enters a locked, non-configured state, called the initialized state, and the Controller System Config Required parameter is turned On. The LTMR controller exits this state only after certain parameters, called required parameters, have been configured.

When commissioning is done, the LTMR controller is no longer locked, and is ready for operations. For information on operating states, see *TeSys T LTMR Motor Management Controller User Guide*.

First Power-up in the LTMCU

Using the LTMCU control operator unit, configuring the **Menu → First Setup** menu parameters clears the Controller System Config Required parameter and brings the LTMR controller out of initialization.

The first time the LTMR controller powers up after leaving the factory, the LTMCU control operator unit LCD automatically displays the First Setup menu, with a list of parameters that need to be configured immediately:

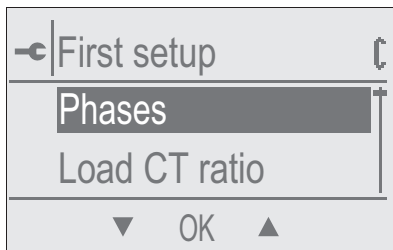

Click OK.

When all parameters are set, the last menu item to show up is End Config:

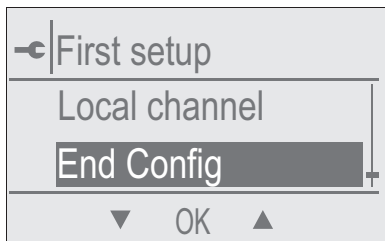

Click OK.

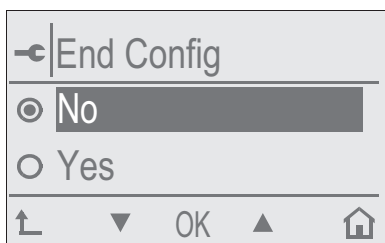

Click Yes to save the configuration.

When the configuration is saved, the First Setup menu is no longer displayed.

Send a Clear All command to the product to access the first setup menu again.

For more information, see the *TeSys T LTMCU Control Operator Unit User's Manual*.

First Power-up in SoMove with the TeSys T DTM

Using SoMove with the TeSys T DTM to set all parameters, at the first power up of the LTMR controller, the Controller System Config Required parameter can be cleared by 2 ways:

- In disconnected mode, by clicking **Communication** → **Store to Device** to download the configuration files
- In connected mode, by clicking **Device** → **command** → **exit configuration** after setting all parameters

Both commands bring the LTMR controller out of initialization.

Required and Optional Parameters

Introduction

In addition to the required parameters, configure optional parameters if required at first power-up or later.

In the LTMCU HMI

In the LTMCU HMI, required and optional parameters are located in the five sub-menus in the Menu.

In SoMove with the TeSys T DTM

In SoMove with the TeSys T DTM, required and optional parameters are located in tree view items in the **parameter list** tab.

FLC (Full Load Current) Settings

FLC Definition

The Full Load Current (FLC) represents the actual full-load current of the motor being protected by the LTMR controller. The FLC is a motor characteristic and can be found on the motor plate.

Many protection parameters are set as a multiple of FLC.

The FLC can be set from FLCmin to FLCmax.

Examples of FLC settings are detailed below.

Other Definitions

Load CT ratio = Load CT primary / (Load CT secondary * Passes)

Current sensor max = Current range max * Load CT ratio

Current range max is determined by the LTMR controller commercial reference. It is stored in units of 0.1 A and has one of the following values: 8.0, 27.0, or 100.0 A.

Contactors rating is stored in units of 0.1 A and is set by the user between 1.0 and 1000.0 A.

FLCmax is defined as the lower of the Current sensor max and the Contactors rating values.

FLCmin = Current sensor max / 20 (rounded to the nearest 0.01 A.). FLCmin is stored internally in units of 0.01 A.

NOTE:

- The modification of the Contactors rating and/or Load CT ratio modifies the value of the FLC.
- Do not set the FLC below the FLCmin.

Conversion of Amperes to FLC Settings

FLC values are stored as a percentage of FLCmax

FLC (in %) = FLC (in A) / FLCmax

NOTE: FLC values must be expressed as a percentage of FLCmax (resolution of 1 %). If you enter an unauthorized value, the LTMR will round it up to the nearest authorized value. For example, on a 0.4-8 A unit, the step between FLCs is 0.08 A. If you try to set an FLC of 0.43 A, the LTMR will round it up to 0.4 A.

Example 1 (No External CTs)

Data:

- FLC (in A) = 0.43 A
- Current range max = 8.0 A
- Load CT primary = 1
- Load CT secondary = 1
- Passes = 1
- Contactors rating = 810.0 A

Calculated parameters with one pass:

- Load CT ratio = Load CT primary / (Load CT secondary * passes) = 1 / (1 * 1) = 1.0
- Current sensor max = Current range max * Load CT ratio = 8.0 * 1.0 = 8.0 A
- FLCmax = min (Current sensor max, Contactors rating) = min (8.0, 810.0) = 8.0 A
- FLCmin = Current sensor max / 20 = 8.0 / 20 = 0.40 A
- FLC (in %) = FLC (in A) / FLCmax = 0.43 / 8.0 = 5 %

Example 2 (No External CTs, Multiple Passes)

Data:

- FLC (in A) = 0.43 A
- Current range max = 8.0 A
- Load CT primary = 1
- Load CT secondary = 1
- Passes = 5
- Contactors rating = 810.0 A

Calculated parameters with five passes:

- Load CT ratio = Load CT primary / (Load CT secondary * passes) = 1 / (1 * 5) = 0.2
- Current sensor max = Current range max * Load CT ratio = 8.0 * 0.2 = 1.6 A
- FLCmax = min (Current sensor max, Contactor rating) = min (1.6, 810.0) = 1.6 A
- FLCmin = Current sensor max / 20 = 1.6 / 20 = 0.08 A
- FLC (in %) = FLC (in A) / FLCmax = 0.43 / 1.6 = 27 %

Example 3 (External CTs, Reduced Contactor Rating)

Data:

- FLC (in A) = 135 A
- Current range max = 8.0 A
- Load CT primary = 200
- Load CT secondary = 1
- Passes = 1
- Contactor rating = 150.0 A

Calculated parameters with one pass:

- Load CT ratio = Load CT primary / (Load CT secondary * passes) = 200 / (1 * 1) = 200.0
- Current sensor max = Current range max * Load CT ratio = 8.0 * 200.0 = 1600.0 A
- FLCmax = min (Current sensor max, Contactor rating) = min (1600.0, 150.0) = 150.0 A
- FLCmin = Current sensor max / 20 = 1600.0 / 20 = 80.0 A
- FLC (in %) = FLC (in A) / FLCmax = 135 / 150.0 = 90 %

Verifying System Wiring

Overview

After all required and optional parameters have been configured, be sure to check your system's wiring, which can include:

- Motor power wiring
- LTMR controller wiring
- External current transformer wiring
- Diagnostic wiring
- I/O wiring

Motor Power Wiring

To verify the motor power wiring, check the following:

Look At...	Action
The motor nameplate	Confirm that the motor generates current and voltage within the ranges of the LTMR controller.
The power wiring diagram	Visually confirm that the actual power wiring matches the intended power wiring, as described in the power wiring diagram.
The list of faults and warnings in SoMove with the TeSys T DTM or the LCD display of the HMI device	Look for any of the following faults or warnings: <ul style="list-style-type: none"> • Overpower • Underpower • Over power factor • Under power factor
The list of all or read only parameters in SoMove with the TeSys T DTM or the scrolling HMI display of the HMI device	Look for unexpected values in the following parameters: <ul style="list-style-type: none"> • Active power • Reactive power • Power factor

Control Circuit Wiring

To verify control circuit wiring, check the following:

Look At...	Action
The control wiring diagram	Visually confirm that the actual control wiring matches the intended control wiring, as described in the control wiring diagram.
The LTMR controller Power LED	If the LED is off, the LTMR controller may not be receiving power.
The LTMR controller HMI LED	If the LED is off, the LTMR controller may not be communicating with the LTMCU or the PC running SoMove.
The LTME expansion module Power LED	If the LED is off, the LTME expansion module may not be receiving power.

Current Transformer Wiring

Verify the load current transformer wiring and, if the application includes external load current transformers, also verify that wiring by checking the following:

Look At...	Action
The external CT wiring diagram	Visually confirm that the actual wiring matches the intended wiring, as described in the wiring diagram.
The following load CT parameter settings, using SoMove with the TeSys T DTM: <ul style="list-style-type: none"> • Load CT Ratio • Load CT Primary • Load CT Secondary • Load CT Multiple Passes 	Confirm that the Load CT Ratio parameter, or the combination of Load CT Primary and Load CT Secondary parameters accurately reflect the intended load CT ratio. Visually confirm that the Load CT Multiple Passes parameter accurately reflects the number of passes the wiring makes through the LTMR controller's embedded CT windows.
The following load motor parameter setting, using SoMove with the TeSys T DTM: <ul style="list-style-type: none"> • Motor Phases 	Visually confirm that the motor and LTMR controller are wired for the number of phases set in the Motor Phases parameter.
The following load motor parameter setting, using either SoMove with the TeSys T DTM or the LCD display of the HMI device: <ul style="list-style-type: none"> • Motor Phases Sequence 	If the motor is a three-phase motor, visually check that the phase wiring sequence matches the Motor Phases Sequence parameter setting.

Diagnostic Wiring

Verify the wiring for any motor temperature sensing device or external ground current transformer, if the application includes these devices, by checking the following:

Look At...	Action
The wiring diagram	Visually confirm that the actual wiring matches the intended wiring, as described in the wiring diagram.
The external ground CT specifications - and - The following ground CT parameter settings, using SoMove with the TeSys T DTM: <ul style="list-style-type: none"> ● Ground CT Primary ● Ground CT Secondary 	Confirm that the combination of Ground CT Primary and Ground CT Secondary parameters accurately reflect the intended ground CT ratio.
The motor temp sensor specifications -and - The following parameter setting, using either SoMove with the TeSys T DTM or the LCD display of the HMI device: <ul style="list-style-type: none"> ● Motor Temp Sensor 	Confirm that the motor temp sensor actually employed is the same sensor type as set in the Motor Temp Sensor parameter.

I/O Wiring

Verify the wiring for any I/O connections by checking the following:

Look At...	Action
The wiring diagram	Visually confirm that the actual wiring matches the intended wiring, as described in the wiring diagram.
The AUX1 (Run 1), AUX2 (Run 2), and Stop buttons on the HMI device - and - The following parameter setting, using either SoMove with the TeSys T DTM or the LCD display of the HMI device: <ul style="list-style-type: none"> ● Control Local Channel Setting 	Confirm that each command performs the intended start or stop function, when control is via the terminal strip or the HMI port.
The Reset button on the HMI device - and - The following parameter setting, using either SoMove with the TeSys T DTM or the LCD display of the HMI device: <ul style="list-style-type: none"> ● Thermal Overload Fault Reset 	Confirm that the HMI can command a manual fault reset, when control is set to manual.
The PLC, if the LTMR controller is connected to a network - and - The following parameter setting, using either SoMove with the TeSys T DTM or the LCD display of the HMI device: <ul style="list-style-type: none"> ● Thermal Overload Fault Reset 	Confirm that the PLC can command the intended start, stop and remote reset functions.

Verify Configuration

Overview

The final step in the commissioning process is to verify that all configurable parameters used in the application are properly configured.

When performing this task, a master list of all the parameters to be configured and the desired settings is required. It is imperative to compare this list against the actual settings of the configured parameters.

Process

Verifying parameter settings is a three-part process:

- Transfer the configuration file from the LTMR controller to the PC running SoMove with the TeSys T DTM. This allows to view the LTMR controller's present parameter settings.
For information on transferring files from the LTMR controller to the PC, refer to the *TeSys T DTM for SoMove FDT Container Online help*.
- Compare the master list of intended parameters and settings against the same settings located in the **parameter list** tab in SoMove with the TeSys T DTM. SoMove can be provided in the **parameter list** tab, the list of **Modified** settings. It is a quick way to see what settings have been done.
- Change the configuration settings as desired. Do this using:
 - Either SoMove with the TeSys T DTM, then download the edited file from the PC to the LTMR controller.
For information on transferring files from the PC to the LTMR controller, refer to the *TeSys T DTM for SoMove FDT Container Online help*.
 - Or LTMCU HMI: to edit parameters located in the Menu, navigate to the sub-menu settings and make the appropriate edits.

Chapter 4

Maintenance

Overview

This chapter describes the maintenance and self-diagnostic features of the LTMR controller and the expansion module.

WARNING

UNINTENDED EQUIPMENT OPERATION

The application of this product requires expertise in the design and programming of control systems. Only persons with such expertise should be allowed to program, install, alter, and apply this product. Follow all local and national safety codes and standards.

Failure to follow these instructions can result in death, serious injury, or equipment damage.

What Is in This Chapter?

This chapter contains the following topics:

Topic	Page
Detecting Problems	58
Troubleshooting	59
Preventive Maintenance	61
Replacing an LTMR Controller and LTME Expansion Module	63
Communication Warnings and Faults	64

Detecting Problems

Overview

The LTMR controller and the expansion module perform self-diagnostic checks at power-up and during operation.

Problems with either the LTMR controller or expansion module can be detected using

- Power and Alarm LEDs on the LTMR controller,
- Power and Input LEDs on the expansion module,
- LCD Display on either a Magelis XBTN410 HMI device or a TeSys T LTMCU Control Operator Unit connected to the LTMR controller's HMI port, or
- SoMove with the TeSys T DTM running on a PC connected to the LTMR controller's HMI port.

Device LEDs

The LEDs on the LTMR controller and expansion module can indicate the following problems:

LTMR LED			LTME LED	Problem
Power	Alarm	PLC Alarm	Power	
Off	Solid red	-	-	Internal fault
On	Solid red	-	-	Protection fault
On	Flashing red (2x per second)	-	-	Protection warning
On	Flashing red (5x per second)	-	-	Load shed or rapid cycle
On	-	-	Solid red	Internal fault

Magelis XBT HMI Device

The Magelis XBTN410 HMI automatically displays information about a fault or warning, including LTMR controller self-diagnostic faults and warnings, when it occurs.

For information about the display of faults and warnings when the HMI is used in a one-to-many configuration, see *Faults Management* in *TeSys T LTMR Motor Management Controller User Guide*.

LTMCU Control Operator Unit

The TeSys T LTMCU Control Operator Unit automatically displays information about a fault or warning.

For more information, see *Faults and Warnings Display* in *TeSys T LTMCU Control Operator Unit User's Manual*.

SoMove with the TeSys T DTM

SoMove with the TeSys T DTM displays a visual array of active faults and warnings, including LTMR controller self-diagnostic faults and warnings, when these faults occur.

For information about this display of active faults and warnings, refer to the *TeSys T DTM for SoMove FDT Container Online help*.

Troubleshooting

Self-Diagnostic Tests

The LTMR controller performs self-diagnostic tests at power-up and during operation. These tests, the errors they detect, and the steps to take in response to a problem are described below:

Type	Error	Action
Major internal faults	Internal temperature fault	This fault indicates a warning at 80°C, a minor fault at 85°C, and a major fault at 100°C. Take steps to reduce ambient temperature, including: <ul style="list-style-type: none"> • Add an auxiliary cooling fan • Remount the LTMR controller and expansion module to provide more surrounding free space. If the condition persists: <ol style="list-style-type: none"> 1 Cycle power. 2 Wait 30 s. 3 If the fault persists, replace the LTMR controller.
	CPU failure	These faults indicate a hardware failure. Take the following steps: <ol style="list-style-type: none"> 1 Cycle power. 2 Wait 30 s. 3 If the fault persists, replace the LTMR controller.
	Program checksum error	
	RAM test error	
	Stack overflow	
	Stack underflow	
Watchdog timeout		
Minor internal faults	Invalid configuration error	Indicates either a bad checksum (Config checksum error) or good checksum but bad data (Invalid config error). Both caused by hardware failure. Take the following steps: <ol style="list-style-type: none"> 1 Cycle power and wait 30 s. 2 Reset the configuration settings to factory settings. 3 If the fault persists, replace the LTMR controller.
	Configuration checksum (EEROM) error	
	Internal network communications failure	These faults indicate a hardware failure. Take the following steps: <ol style="list-style-type: none"> 1 Cycle power and wait 30 s. 2 If the fault persists, replace the LTMR controller.
	A/D out of range error	
Diagnostic errors	Start command check	Check the following: <ul style="list-style-type: none"> • Relay outputs • All wiring, including: <ul style="list-style-type: none"> ○ Control wiring circuit, including all electromechanical devices ○ Power wiring circuit, including all components ○ Load CT wiring. After all checks are complete: <ol style="list-style-type: none"> 1 Reset the fault. 2 If the fault persists, cycle power and wait 30 s. 3 If the fault persists, replace the LTMR controller.
	Stop command check	
	Stop check back	
	Run check back	

Type	Error	Action
Wiring/config errors	CT reversal error	<p>Correct the polarity of the CTs. Be sure that:</p> <ul style="list-style-type: none"> ● All external CTs face the same direction ● All load CT wiring passes through windows in the same direction <p>After the check is complete:</p> <ol style="list-style-type: none"> 1 Perform a fault reset. 2 If the fault persists, cycle power and wait 30 s. 3 If the fault still persists, replace the LTMR controller.
	Current/Voltage phase reversal error	<p>Check:</p> <ul style="list-style-type: none"> ● L1, L2 and L3 wiring connection to be sure wires are not crossed ● Motor Phases Sequence parameter setting (ABC versus ACB) <p>After all checks are complete:</p> <ol style="list-style-type: none"> 1 Perform a fault reset. 2 If the fault persists, cycle power and wait 30 s. 3 If the fault persists, replace the LTMR controller.
	Phase configuration error	
	PTC connection error	<p>Check for:</p> <ul style="list-style-type: none"> ● Short circuit or open circuit in the motor temp sensor wiring ● Wrong type of motor temp sensing device ● Improper configuration of parameters for selected device. <p>After all checks are complete:</p> <ol style="list-style-type: none"> 1 Perform a fault reset. 2 If the fault persists, cycle power and wait 30 s. 3 If the fault persists, replace the LTMR controller.
Voltage phase loss error	<p>Check for:</p> <ul style="list-style-type: none"> ● Improper wiring, such as loose terminations ● Blown fuse ● Cut wire ● Single-phase motor configured for 3-phase operation ● Failure to wire a single phase motor through both A and C load CT windows ● Failure of power source (for example, utility power failure). <p>After all checks are complete:</p> <ol style="list-style-type: none"> 1 Perform fault reset. 2 If the fault persists, cycle power and wait 30 s. 3 If the fault persists, replace the LTMR controller. 	

Preventive Maintenance

Overview

The following protective measures should be performed between major system checks, to help maintain your system and protect it against irrecoverable hardware or software failure:

- Continuously review operating statistics,
- Save LTMR controller parameter configuration settings to a backup file,
- Maintain the LTMR controller's operating environment,
- Periodically perform a LTMR controller self test,
- Check the LTMR controller internal clock to ensure accuracy.

Statistics

The LTMR controller collects the following types of information:

- Real-time voltage, current, power, temperature, I/O and fault data.
- A count of the number of faults, by fault type, that occurred since last power-up.
- A time-stamped history of the state of the LTMR controller (displaying measures of voltage, current, power, and temperature) at the moment that each of the previous 5 faults occurred.

Use either SoMove with the TeSys T DTM, a Magelis XBTN410 HMI, or a TeSys T LTMCU Control Operator Unit to access and review these statistics. Analyze this information to determine whether the actual record of operations indicates a problem.

Configuration Settings

In the event of irrecoverable LTMR controller failure, you can quickly restore configuration settings if you saved these settings to a file. When the LTMR controller is first configured, and every subsequent time any configuration settings are changed, use SoMove with the TeSys T DTM to save the parameter settings to a file.

To save a configuration file:

- Select **File** → **Save As...**

To restore the saved configuration file:

1. Open the saved file: Select **File** → **Open** (then navigate to the file).
2. Download the configuration to the new controller.
3. Select **Communication** → **Store to Device**.

Environment

Like any other electronic device, the LTMR controller is affected by its physical environment. Provide a friendly environment by taking common-sense preventive measures, including:

- Scheduling periodic examinations of battery packs, fuses, power strips, batteries, surge suppressors, and power supplies.
- Keeping the LTMR controller, the panel, and all devices clean. An unobstructed flow of air will prevent dust build-up, which can lead to a short-circuit condition.
- Remaining alert to the possibility of other equipment producing electromagnetic radiation. Be sure no other devices cause electromagnetic interference with the LTMR controller.

Self Test with Motor Off

Perform a self test by either

- Holding down the Test/Reset button on the face of the LTMR controller for more than three seconds and up to 15 seconds, or
- Setting the Self Test Command parameter.

A self test can be performed only if

- No faults exist,
- The Self Test Enable parameter is set (factory setting).

The LTMR controller performs the following checks during a self test:

- Watchdog check
- RAM check

During the self-test sequence, the LTMR controller calibrates the thermal memory time constant, which keeps track of time while it is not powered.

If any of the above tests fails, a minor internal fault occurs. If not, the self test continues and the LTMR controller performs:

- LTME expansion module test (if it is connected to an expansion module). If this test fails, the LTMR controller experiences a minor internal fault.
- Internal communication test. If this test fails, the LTMR controller experiences a minor internal fault.
- LED test: turns all LEDs off, then turns each LED on in sequence:
 - HMI communication activity LED
 - Power LED
 - Fallback LED
 - PLC communication activity LED

At the end of the test, all LEDs return to their initial state.

- Output relay test: opens all relays, and restores them to their original state only after a reset command executes, or power is cycled.

If current is measured during the relay self test, the LTMR controller experiences a minor internal fault.

During the LTMR self test, a "self test" string displays on the HMI device.

During a self test, the LTMR controller sets the Self Test Command parameter to 1. When the self test finishes, this parameter is reset to 0.

Self Test with Motor On

Perform a self test by using

- The Test/Reset button on the face of the LTMR controller,
- Menu command from the HMI connected to the RJ45 port,
- SoMove with the TeSys T DTM, or
- PLC.

When the motor is On, performing a self test simulates a thermal fault, in order to check if the logic output O.4 is working correctly. It triggers a Thermal Overload fault.

During a self test, the LTMR controller sets the Self Test Command parameter to 1. When the self test finishes, this parameter is reset to 0.

Internal Clock

To ensure an accurate record of faults, be sure to maintain the LTMR controller's internal clock. The LTMR controller time stamps all faults, using the value stored in the Date And Time Setting parameter.

Internal clock accuracy is +/-1 second per hour. If power is continuously applied for one year, the internal clock accuracy is +/-30 minutes per year.

If power is turned Off for 30 minutes or less, the LTMR controller retains its internal clock settings, with accuracy of +/- 2 minutes.

If power is turned Off for more than 30 minutes, the LTMR controller resets its internal clock to the time when power was turned Off.

Replacing an LTMR Controller and LTME Expansion Module

Overview

Questions to consider in advance of replacing either an LTMR controller or an LTME expansion module are:

- Is the replacement device the same model as the original?
- Have the configuration settings of the LTMR controller been saved, and are they available to be transferred to its replacement?

Be sure the motor is turned off before replacing either the LTMR controller or the LTME expansion module.

Replacing the LTMR Controller

The time to plan for the replacement of an LTMR controller is:

- When the LTMR controller settings are initially configured, and
- Any time that one or more of its settings are subsequently re-configured

Because setting values may not be accessible when the LTMR controller is replaced, for example, in case of device failure, you should create a record of setting values whenever they are made.

Using SoMove with the TeSys T DTM, all of the LTMR controller's configured settings, except for date and time, can be saved to a file. Once saved, you can use SoMove with the TeSys T DTM to transfer these settings either to the original LTMR controller or to its replacement.

NOTE: Only configured settings are saved. Historical statistical data is not saved, and therefore cannot be applied to a replacement LTMR controller.

For information on how to use SoMove software to create, save and transfer configuration setting files, refer to the *SoMove Lite Online Help*.

Replacing the Expansion Module

The primary consideration in replacing an LTME expansion module, is to replace it with the same model, 24 Vdc or 110-240 Vac, as the original.

Retiring Devices

Both the LTMR controller and the LTME expansion module contain electronic boards that require particular treatment at the end of their useful life. When retiring a device be sure to observe all applicable laws, regulations and practices.

Communication Warnings and Faults

Introduction

Communication warnings and faults are managed in a standard way, like any other types of warnings and faults.

The presence of a fault is signaled by various indicators:

- State of the LEDs:
 - On LTMR Ethernet controllers: 3 LEDs are dedicated to communication, 1 STS LED and 2 LK/ACT LEDs, one for each network port connector.
 - On LTMR Modbus controllers: 1 LED is dedicated to communication, PLC Comm.
 - On LTMR PROFIBUS DP controllers: 1 LED is dedicated to communication, BF.
 - On LTMR CANopen controllers: 1 LED is dedicated to communication, Status.
 - On LTMR DeviceNet controllers: 1 LED is dedicated to communication, MNS.
- State of the output relays
- Warning
- Message(s) displayed on HMI screen
- Presence of an exception code (such as a report from the PLC)

PLC Communication Loss

A communication loss is managed like any other fault.

The LTMR controller monitors the communication with the PLC. Using an adjustable network idle time (timeout), the LTMR controller watchdog function can report a network loss (firmware watchdog).

NOTE: This timeout is not defined in the LTMR PROFIBUS DP controller but at the PROFIBUS DP master level. If the PROFIBUS DP master allows the modification of this timeout, then, its value must be transmitted by the master to the LTMR PROFIBUS DP controller.

In the event of a network loss, the LTMR controller can be configured to take certain actions. These depend on the control mode that the LTMR controller was operating in prior to the network loss.

If PLC-LTMR controller communication is lost while the LTMR controller is in network control mode, the LTMR controller enters the fallback state. If PLC- LTMR controller communication is lost while the LTMR controller is in local control mode, and then the control mode is changed to network control, the LTMR controller enters the fallback state.

If PLC-LTMR controller communication is restored while the control mode is set to network control, the LTMR controller exits the fallback state. If the control mode is changed to local control, the LTMR exits from the fallback state, regardless of the state of PLC-controller communications.

The table below defines the available actions that the LTMR controller can take during a communication loss that the user can select when configuring the LTMR controller.

Network communication loss actions:

LTMR Controller Output Control Mode Prior to Network Loss	Available LTMR Actions After PLC-LTMR Controller Network Loss
Terminal Strip and HMI control	Fault and Warning control possibilities: <ul style="list-style-type: none"> ● Signal nothing ● Activate a warning ● Activate a fault ● Activate a fault and warning
Network control	Fault and Warning control possibilities: <ul style="list-style-type: none"> ● Signal nothing ● Activate a warning ● Activate a fault ● Activate a fault and warning ● The behavior of the LO1 and LO2 relays depends on the motor controller mode and on the fallback strategy chosen

HMI Communication Loss

The LTMR controller monitors the communication with any approved HMI device. Using a fixed network idle time (timeout), the LTMR controller watchdog function can report a network loss. In the event of a communication loss, the LTMR controller can be configured to take certain actions. These depend on the control mode that the LTMR controller was operating in prior to the communication loss.

If HMI-controller communication is lost while the LTMR controller is in HMI control mode, the LTMR controller enters the fallback state. If HMI-LTMR controller communication is lost while the LTMR controller is not in HMI control mode, and then the control mode is changed to HMI control, the LTMR controller enters the fallback state.

If HMI-controller communication is restored while the control mode is set to HMI control, the LTMR exits from the fallback state. If the control mode is changed to Terminal Strip or Network control, the LTMR exits from the fallback state, regardless of the state of HMI-controller communications.

The following table defines the available actions that the LTMR controller may take during a communication loss. Select one of these actions when configuring the LTMR controller.

LTMR Controller Output Control Mode Prior to HMI Loss	Available LTMR Controller Actions After HMI-LTMR Controller HMI Loss
Terminal Strip and network control	Fault and Warning control possibilities: <ul style="list-style-type: none"> ● Signal nothing ● Activate a warning ● Activate a fault ● Activate a fault and warning
HMI control	Fault and Warning control possibilities: <ul style="list-style-type: none"> ● Signal nothing ● Activate a warning ● Activate a fault ● Activate a fault and warning ● The behavior of the LO1 and LO2 relays depends on the motor controller mode and on the fallback strategy chosen

NOTE: For more information about a communication loss and the fallback strategy, refer to the Fallback Condition portion of the topic describing Communication Loss in *TeSys T LTMR Motor Management Controller User Guide*.

Appendices



What Is in This Appendix?

The appendix contains the following chapters:

Chapter	Chapter Name	Page
A	Configurable Parameters	69
B	Wiring Diagrams	83

Appendix A

Configurable Parameters

Overview

The configurable parameters for the LTMR controller and the LTME expansion module are described below. The sequence of parameter configuration depends on the configuration tool utilized, either an HMI device or SoMove with the TeSys T DTM.

Parameters are grouped according to the TeSys T DTM **parameter list** tab. To help you find the link with the variable tables in the Use chapter, each parameter has its corresponding register number attached.

WARNING

RISK OF UNINTENDED CONFIGURATION AND OPERATION

When modifying parameter settings of the LTMR controller:

- Be especially careful if you change parameter settings when the motor is running.
- Disable network control of the LTMR controller to prevent unintended parameter configuration and operation.

Failure to follow these instructions can result in death, serious injury, or equipment damage.

What Is in This Chapter?

This chapter contains the following topics:

Topic	Page
Main Settings	70
Control	71
Communication	73
Thermal	74
Current	75
Voltage	77
Power	79
HMI	80

Main Settings

Phases

Parameter	Setting Range	Factory Setting
Motor phases	<ul style="list-style-type: none"> ● Three-phase motor ● Single-phase motor 	Three-phase motor

Operating Mode

Parameter	Setting Range	Factory Setting
Motor operating mode	<ul style="list-style-type: none"> ● Overload 2-wire ● Overload 3-wire ● Independent 2-wire ● Independent 3-wire ● Reverser 2-wire ● Reverser 3-wire ● Two-step 2-wire ● Two-step 3-wire ● Two-speed 2-wire ● Two-speed 3-wire ● Custom 	Independent 3-wire
Motor star-delta	0 = disabled 1 = enabled	0

Contactors

Parameter	Setting Range	Factory Setting
Contactors rating	1...1,000 A in increments of 0.1 A	810 A

Motor

Parameter	Setting Range	Factory Setting
Motor nominal voltage	110...690 V	400 V
Motor nominal power	0.134...1339.866 HP	10.05 HP
Motor nominal power	0.1...999.9 kW in increments of 0.1 kW	7.5 kW
Motor auxiliary fan cooled	<ul style="list-style-type: none"> ● Disable ● Enable 	Disable
Motor full load current ratio (FLC1)	5...100 % FLCmax in increments of 1 %	5 % FLCmax
Motor full load current	–	–
Motor high speed full load current ratio (FLC2)	5...100 % FLCmax in increments of 1 %	5 % FLCmax
Motor high speed full load current (FLC2)	0...100 A in increments of 1 A	5 A

Load Current Transformer

Parameter	Setting Range	Factory Setting
Load CT primary	1...65,535 in increments of 1	1
Load CT secondary	1...500 in increments of 1	1
Load CT multiple passes	1...100 passes in increments of 1	1

Ground Current Transformer

Parameter	Setting Range	Factory Setting
Ground current mode	<ul style="list-style-type: none"> ● Internal ● External 	Internal
Ground CT primary	1...65,535 in increments of 1	1
Ground CT secondary	1...65,535 in increments of 1	1

Operating Mode

Parameter	Setting Range	Factory Setting
Control direct transition	On / Off	Off
Motor transition timeout	0...999.9 s	1 s
Motor Step 1 to 2 threshold	20...800 % FLC in increments of 1 %	150 % FLC
Motor Step 1 to 2 timeout	0.1...999.9 s	5 s

Inputs/Outputs

Parameter	Setting Range	Factory Setting
Controller AC logic inputs configuration	<ul style="list-style-type: none"> ● Unknown ● Lower than 170V 50Hz ● Lower than 170V 60Hz ● Greater than 170V 50Hz ● Greater than 170V 60Hz 	Unknown
Logic input 3 external ready enable	<ul style="list-style-type: none"> ● Disable ● Enable 	Disable

Rapid Cycle

Parameter	Setting Range	Factory Setting
Rapid cycle lockout timeout	0...9999 s in increments of 1 s	0 s

Local/Remote Control

Parameter	Setting Range	Factory Setting
Control remote channel setting	<ul style="list-style-type: none"> ● Network ● Terminal strip ● HMI 	Network
Control local channel setting	<ul style="list-style-type: none"> ● Terminal strip ● HMI 	Terminal strip
Control transfer mode	<ul style="list-style-type: none"> ● Bump ● Bumpless 	Bump
Control remote local buttons enable	<ul style="list-style-type: none"> ● Disable ● Enable 	Disable
Control remote local default mode	<ul style="list-style-type: none"> ● Remote ● Local 	Remote
Stop HMI disable	<ul style="list-style-type: none"> ● Enable ● Disable 	Disable
Stop terminal strip disable	<ul style="list-style-type: none"> ● Enable ● Disable 	Disable

Diagnostic

Parameter	Setting Range	Factory Setting
Diagnostic fault enable	<ul style="list-style-type: none"> ● Disable ● Enable 	Enable
Diagnostic warning enable	<ul style="list-style-type: none"> ● Disable ● Enable 	Enable
Wiring fault enable	<ul style="list-style-type: none"> ● Disable ● Enable 	Enable
Motor phases sequence	<ul style="list-style-type: none"> ● A B C ● A C B 	A B C

Fault and Warning

Parameter	Setting Range	Factory Setting
Fault reset mode	<ul style="list-style-type: none"> ● Manual or HMI ● Remote by network ● Automatic 	Manual or HMI
Auto-reset attempts group 1 setting	0 = manual, 1, 2, 3, 4, 5 = unlimited number of reset attempts	5
Auto-reset group 1 timeout	0...9,999 s in increments of 1 s	480 s
Auto-reset attempts group 2 setting	0 = manual, 1, 2, 3, 4, 5 = unlimited number of reset attempts	0
Auto-reset group 2 timeout	0...9999 s in increments of 1 s	1,200 s
Auto-reset attempts group 3 setting	0 = manual, 1, 2, 3, 4, 5 = unlimited number of reset attempts	0
Auto-reset group 3 timeout	0...9999 s in increments of 1 s	60 s

Communication

Network Port Control and Fallback Configuration

For information about the configuration parameters of the communication network, refer to

- *TeSys T LTMR Ethernet Communication Guide*
- *TeSys T LTMR Modbus Communication Guide*
- *TeSys T LTMR PROFIBUS DP Communication Guide*
- *TeSys T LTMR CANopen Communication Guide*
- *TeSys T LTMR DeviceNet Communication Guide*

HMI Port

Parameter	Setting Range	Factory Setting
HMI port address setting	1...247	1
HMI port baud rate setting	<ul style="list-style-type: none"> ● 4800 ● 9600 ● 19,200 ● Self detection 	19,200 bits/s
HMI port parity setting	<ul style="list-style-type: none"> ● None ● Even 	Even
HMI port endian setting	<ul style="list-style-type: none"> ● LSW first (little endian) ● MSW first (big endian) 	MSW first (big endian)
HMI port fallback setting	<ul style="list-style-type: none"> ● Hold LO1 LO2 ● Run (2-step) or off ● LO1, LO2 off ● LO1, LO2 on (ovl, ind, cust) or off ● LO1 on or off (2-step) ● LO2 on or off (2-step) 	LO1, LO2 off
HMI port fault enable	<ul style="list-style-type: none"> ● Disable ● Enable 	Disable
HMI port warning enable	<ul style="list-style-type: none"> ● Disable ● Enable 	Disable
Config via HMI engineering tool enable	<ul style="list-style-type: none"> ● Forbidden ● Allowed 	Allowed
Config via HMI keypad enable	<ul style="list-style-type: none"> ● Forbidden ● Allowed 	Allowed

Thermal

Thermal Overload

Parameter	Setting Range	Factory Setting
Thermal overload mode	<ul style="list-style-type: none"> ● Definite ● Inverse thermal 	Inverse thermal
Motor trip class	<ul style="list-style-type: none"> ● Motor class 5 ● Motor class 10 ● Motor class 15 ● Motor class 20 ● Motor class 25 ● Motor class 30 	Motor class 5
Thermal overload fault enable	<ul style="list-style-type: none"> ● Disable ● Enable 	Enable
Thermal overload fault reset threshold	35...95 % in increments of 1 %	75 %
Thermal overload warning enable	<ul style="list-style-type: none"> ● Disable ● Enable 	Enable
Thermal overload warning threshold	10...100 % in increments of 1 %	85 %
Long start fault timeout	1...200 s in increments of 1 s	10 s
Thermal overload fault enable	<ul style="list-style-type: none"> ● Disable ● Enable 	Enable
Thermal overload fault definite timeout	1...300 s in increments of 1 s	10 s
Thermal overload warning enable	<ul style="list-style-type: none"> ● Disable ● Enable 	Enable

Motor Temperature

Parameters	Setting range	Factory setting
Motor temperature sensor type	<ul style="list-style-type: none"> ● None ● PTC binary ● PT100 ● PTC analog ● NTC analog 	None
Motor temperature sensor fault enable	<ul style="list-style-type: none"> ● Disable ● Enable 	Disable
Motor temperature sensor fault threshold	20...6,500 Ω	20 Ω
Motor temperature sensor fault threshold degree	0...200 °C	0 °C
Motor temperature sensor warning enable	<ul style="list-style-type: none"> ● Disable ● Enable 	Disable
Motor temperature sensor warning threshold	20...6,500 Ω	20 Ω
Motor temperature sensor warning threshold degree	0...200 °C	0 °C

Current

Ground Current

Parameters	Setting range	Factory setting
Ground current disable while motor starting	<ul style="list-style-type: none"> ● No ● Yes 	No
Ground current fault enable	<ul style="list-style-type: none"> ● Disable ● Enable 	Enable
Internal ground current fault threshold	20...500 % FLCmin in increments of 1 %	30 % FLCmin
Internal ground current fault timeout	0.5...25 s in increments of 0.1 s	1 s
External ground current fault threshold	0.01...20 A in increments of 0.01 A	1 A
External ground current fault timeout	0.1...25 s in increments of 0.01 s	0.5 s
Ground Current warning enable	<ul style="list-style-type: none"> ● Disable ● Enable 	Enable
Internal ground current warning threshold	50...500 % FLCmin in increments of 1 %	50 % FLCmin
External ground current warning threshold	0.01...20 A in increments of 0.01 A	1 A

Phases

Parameters	Setting range	Factory setting
Current phase imbalance fault enable	<ul style="list-style-type: none"> ● Disable ● Enable 	Enable
Current phase imbalance fault threshold	10...70 % in increments of 1 %	10 %
Current phase imbalance fault timeout starting	0.2...20 s in increments of 0.1 s	0.7 s
Current phase imbalance fault timeout running	0.2...20 s in increments of 0.1 s	5 s
Current phase imbalance warning enable	<ul style="list-style-type: none"> ● Disable ● Enable 	Disable
Current phase imbalance warning threshold	10...70 % in increments of 1 %	10 %
Current phase loss fault enable	<ul style="list-style-type: none"> ● Disable ● Enable 	Enable
Current phase loss timeout	0.1...30 s in increments of 0.1 s	3 s
Current phase loss warning enable	<ul style="list-style-type: none"> ● Disable ● Enable 	Enable
Current phase reversal fault enable	<ul style="list-style-type: none"> ● Disable ● Enable 	Disable

Long Start

Parameters	Setting range	Factory setting
Long start fault enable	<ul style="list-style-type: none"> ● Disable ● Enable 	Enable
Long start fault threshold	100...800 % FLC in increments of 1 %	100 % FLC
Long start fault timeout	1...200 s in increments of 1 s	10 s

Jam

Parameters	Setting range	Factory setting
Jam fault enable	<ul style="list-style-type: none"> ● Disable ● Enable 	Enable
Jam fault threshold	100...800 % FLC in increments of 1 %	200 % FLC
Jam fault timeout	1...30 s in increments of 1 s	5 s
Jam warning enable	<ul style="list-style-type: none"> ● Disable ● Enable 	Disable
Jam warning threshold	100...800 % FLC in increments of 1 %	200 % FLC

Undercurrent

Parameters	Setting range	Factory setting
Undercurrent Fault Enable	<ul style="list-style-type: none"> ● Disable ● Enable 	Disable
Undercurrent Fault Threshold	30...100 % FLC in increments of 1 %	50 % FLC
Undercurrent Fault Timeout	1...200 s in increments of 1 s	10 s
Undercurrent Warning Enable	<ul style="list-style-type: none"> ● Disable ● Enable 	Disable
Undercurrent Warning Threshold	30...100 % FLC in increments of 1 %	50 % FLC

Overcurrent

Parameters	Setting range	Factory setting
Overcurrent fault enable	<ul style="list-style-type: none"> ● Disable ● Enable 	Disable
Overcurrent Fault Threshold	20...800 % FLC in increments of 1 %	200 % FLC
Overcurrent fault timeout	1...250 s in increments of 1 s	10 s
Overcurrent warning enable	<ul style="list-style-type: none"> ● Disable ● Enable 	Disable
Overcurrent warning threshold	20...800 % FLC in increments of 1 %	200 % FLC

Voltage

Phases

Parameters	Setting range	Factory setting
Voltage phase imbalance fault enable	<ul style="list-style-type: none"> ● Disable ● Enable 	Disable
Voltage phase imbalance fault threshold	3...15 % of the calculated imbalance in increments of 1 %	10 % imbalance
Voltage phase imbalance fault timeout starting	0.2...20 s in increments of 1 s	0.7 s
Voltage phase imbalance fault timeout running	0.2...20 s in increments of 1 s	2 s
Voltage phase imbalance warning enable	<ul style="list-style-type: none"> ● Disable ● Enable 	Disable
Voltage phase imbalance warning threshold	3...15 % of the calculated imbalance in increments of 1 %	10 % imbalance
Voltage phase loss fault enable	<ul style="list-style-type: none"> ● Disable ● Enable 	Disable
Voltage phase loss fault timeout	0.1...30 s in increments of 0.1 s	3 s
Voltage phase loss warning enable	<ul style="list-style-type: none"> ● Disable ● Enable 	Disable
Voltage phase reversal fault enable	<ul style="list-style-type: none"> ● Disable ● Enable 	Disable

Undervoltage

Parameters	Setting range	Factory setting
Undervoltage fault enable	<ul style="list-style-type: none"> ● Disable ● Enable 	Disable
Undervoltage fault threshold	70...99 % of Motor nominal voltage in increments of 1 %	85 % of Motor nominal voltage
Undervoltage fault timeout	0.2...25 s in increments of 0.1 s	3 s
Undervoltage warning enable	<ul style="list-style-type: none"> ● Disable ● Enable 	Disable
Undervoltage warning threshold	70...99 % of Motor nominal voltage in increments of 1 %	85 % of Motor nominal voltage

Overvoltage

Parameters	Setting range	Factory setting
Overvoltage fault enable	<ul style="list-style-type: none"> ● Disable ● Enable 	Disable
Overvoltage fault threshold	101...115 % of Motor nominal voltage in increments of 1 %	110 % of Motor nominal voltage
Overvoltage fault timeout	0.2...25 s in increments of 0.1 s	3 s
Overvoltage warning enable	<ul style="list-style-type: none"> ● Disable ● Enable 	Disable
Overvoltage warning threshold	101...115 % of Motor nominal voltage in increments of 1 %	110 % of Motor nominal voltage

Voltage Dip

Parameters	Setting range	Factory setting
Voltage dip mode	<ul style="list-style-type: none"> ● None ● Load shedding ● Auto-restart 	None
Voltage dip threshold	50...115 % of Motor nominal voltage in increments of 1 %	65 % of Motor nominal voltage
Load shedding timeout	1...9999 s in increments of 1 s	10 s
Voltage dip restart threshold	65...115 % of Motor nominal voltage in increments of 1 %	90 % of Motor nominal voltage
Voltage dip restart timeout	0...9999 s in increments of 1 s	2 s
Voltage dip threshold	50...115 % of Motor nominal voltage in increments of 1 %	65 % of Motor nominal voltage
Voltage dip restart threshold	65...115 % of Motor nominal voltage in increments of 1 %	90 % of Motor nominal voltage
Voltage dip restart timeout	0...9999 s in increments of 1 s	2 s
Auto restart immediate timeout	0...0.4 s in increments of 0.1 s	0.2 s
Auto restart delayed timeout	0...301 s in increments of 1 s	4 s

Power

Underpower

Parameters	Setting range	Factory setting
Underpower fault enable	<ul style="list-style-type: none"> ● Disable ● Enable 	Disable
Underpower fault threshold	20...800 % of Motor nominal power in increments of 1 %	20 % of Motor nominal power
Underpower fault timeout	1...100 s in increments of 1 s	60 s
Underpower warning enable	<ul style="list-style-type: none"> ● Disable ● Enable 	Disable
Underpower warning threshold	20...800 % of Motor nominal power in increments of 1 %	30 % of Motor nominal power

Overpower

Parameters	Setting range	Factory setting
Overpower fault enable	<ul style="list-style-type: none"> ● Disable ● Enable 	Disable
Overpower fault threshold	20...800 % of Motor nominal power in increments of 1 %	150 % of Motor nominal power
Overpower fault timeout	1...100 s in increments of 1 s	60 s
Overpower warning enable	<ul style="list-style-type: none"> ● Disable ● Enable 	Disable
Overpower warning threshold	20...800 % of Motor nominal power in increments of 1 %	150 % of Motor nominal power

Under Power Factor

Parameters	Setting range	Factory setting
Under power factor fault enable	<ul style="list-style-type: none"> ● Disable ● Enable 	Disable
Under power factor fault threshold	0...1 in increments of 0.01	0.6
Under power factor fault timeout	1...25 s in increments of 0.1 s	10 s
Under power factor warning enable	<ul style="list-style-type: none"> ● Disable ● Enable 	Disable
Under power factor warning threshold	0...1 in increments of 0.01	0.6

Over Power Factor

Parameters	Setting range	Factory setting
Over power factor fault enable	<ul style="list-style-type: none"> ● Disable ● Enable 	Disable
Over power factor fault threshold	0...1 in increments of 0.01	0.9
Under power factor fault timeout	1...25 s in increments of 0.1 s	10 s
Over power factor warning enable	<ul style="list-style-type: none"> ● Disable ● Enable 	Disable
Over power factor warning threshold	0...1 in increments of 0.01	0.9

HMI

HMI Display

Parameter	Setting Range	Factory Setting
HMI language setting	–	English
HMI display contrast setting	0...255	127
HMI display brightness setting	0...255	127
HMI motor status LED color	<ul style="list-style-type: none"> ● Red ● Green 	Red

HMI Keyboard

Parameter	Setting Range	Factory Setting
Control remote local buttons enable	<ul style="list-style-type: none"> ● Disable ● Enable 	Disable
Stop HMI disable	<ul style="list-style-type: none"> ● Yes ● No 	No

HMI Display Scroll View

Parameter	Setting Range	Factory Setting
HMI display motor status enable	<ul style="list-style-type: none"> ● Hidden ● Displayed 	Hidden
HMI display date enable	<ul style="list-style-type: none"> ● Hidden ● Displayed 	Hidden
HMI display time enable	<ul style="list-style-type: none"> ● Hidden ● Displayed 	Hidden
HMI display operating time enable	<ul style="list-style-type: none"> ● Hidden ● Displayed 	Hidden
HMI display starts per hour enable	<ul style="list-style-type: none"> ● Hidden ● Displayed 	Hidden
HMI display I/O status enable	<ul style="list-style-type: none"> ● Hidden ● Displayed 	Hidden
HMI display control mode enable	<ul style="list-style-type: none"> ● Hidden ● Displayed 	Hidden
HMI display thermal capacity level enable	<ul style="list-style-type: none"> ● Hidden ● Displayed 	Hidden
HMI display thermal capacity remaining enable	<ul style="list-style-type: none"> ● Hidden ● Displayed 	Hidden
HMI display time to trip enable	<ul style="list-style-type: none"> ● Hidden ● Displayed 	Hidden
HMI motor temperature sensor enable	<ul style="list-style-type: none"> ● Hidden ● Displayed 	Hidden
HMI display temperature sensor degree CF	<ul style="list-style-type: none"> ● °C ● °F 	°C
HMI display average current enable	<ul style="list-style-type: none"> ● Hidden ● Displayed 	Displayed
HMI display L1 current enable	<ul style="list-style-type: none"> ● Hidden ● Displayed 	Hidden
HMI display L2 current enable	<ul style="list-style-type: none"> ● Hidden ● Displayed 	Hidden
HMI display L3 current enable	<ul style="list-style-type: none"> ● Hidden ● Displayed 	Hidden
HMI display average current ratio enable	<ul style="list-style-type: none"> ● Hidden ● Displayed 	Hidden

Parameter	Setting Range	Factory Setting
HMI display L1 current ratio enable	<ul style="list-style-type: none"> ● Hidden ● Displayed 	Hidden
LHMI display L2 current ratio enable	<ul style="list-style-type: none"> ● Hidden ● Displayed 	Hidden
HMI display L3 current ratio enable	<ul style="list-style-type: none"> ● Hidden ● Displayed 	Hidden
HMI display current phase imbalance enable	<ul style="list-style-type: none"> ● Hidden ● Displayed 	Hidden
HMI display ground current enable	<ul style="list-style-type: none"> ● Hidden ● Displayed 	Hidden
HMI display start statistics enable	<ul style="list-style-type: none"> ● Hidden ● Displayed 	Hidden
HMI display average voltage enable	<ul style="list-style-type: none"> ● Hidden ● Displayed 	Hidden
HMI display L1-L2 voltage enable	<ul style="list-style-type: none"> ● Hidden ● Displayed 	Hidden
HMI display L2-L3 voltage enable	<ul style="list-style-type: none"> ● Hidden ● Displayed 	Hidden
HMI display L3-L1 voltage enable	<ul style="list-style-type: none"> ● Hidden ● Displayed 	Hidden
HMI display voltage phase imbalance enable	<ul style="list-style-type: none"> ● Hidden ● Displayed 	Hidden
HMI display frequency enable	<ul style="list-style-type: none"> ● Hidden ● Displayed 	Hidden
HMI display power factor enable	<ul style="list-style-type: none"> ● Hidden ● Displayed 	Hidden
HMI display active power enable	<ul style="list-style-type: none"> ● Hidden ● Displayed 	Hidden
HMI display reactive power enable	<ul style="list-style-type: none"> ● Hidden ● Displayed 	Hidden
HMI display power consumption enable	<ul style="list-style-type: none"> ● Hidden ● Displayed 	Hidden

Appendix B

Wiring Diagrams

Overview

The LTMR operating mode wiring diagrams can be drawn according to IEC or NEMA standards.

DANGER

HAZARD OF ELECTRIC SHOCK, EXPLOSION, OR ARC FLASH

- Turn off all power supplying this equipment before working on it.
- Apply appropriate personal protective equipment (PPE) and follow safe electrical work practices.

Failure to follow these instructions will result in death or serious injury.

NOTICE

LOGIC INPUTS DESTRUCTION HAZARD

- Connect the LTMR controller's inputs using the three Common (C) terminals connected to the A1 control voltage via an internal filter.
- Do not connect the Common (C) terminal to the A1 or A2 control voltage inputs.

Failure to follow these instructions can result in equipment damage.

What Is in This Chapter?

This chapter contains the following sections:

Section	Topic	Page
B.1	IEC Format Wiring Diagrams	84
B.2	NEMA Format Wiring Diagrams	103

Section B.1

IEC Format Wiring Diagrams

Overview

This section contains the wiring diagrams corresponding to the five pre-configured operating modes:

Overload	Monitoring of the motor load where control (start/stop) of the motor load is achieved by a mechanism other than the controller
Independent	Direct-on-line (across-the-line) full-voltage non-reversing motor starting applications
Reverser	Direct-on-line (across-the-line) full-voltage reversing motor starting applications
Two-Step	Reduced voltage starting motor applications, including: <ul style="list-style-type: none"> ● Wye-Delta ● Open Transition Primary Resistor ● Open Transition Autotransformer
Two-Speed	Two-speed motor applications for motor types, including: <ul style="list-style-type: none"> ● Dahlander (consequent pole) ● Pole Changer

Each application is described individually, with:

One complete application diagram (including power and control)	3-wire (impulse) terminal strip control
Three partial diagrams (control logic input wiring variants)	2-wire (maintained) terminal strip control
	3-wire (impulse) terminal strip control with network control selectable
	2-wire (maintained) terminal strip control with network control selectable

What Is in This Section?

This section contains the following topics:

Topic	Page
Overload Mode Wiring Diagrams	85
Independent Mode Wiring Diagrams	89
Reverser Mode Wiring Diagrams	91
Two-Step Wye-Delta Mode Wiring Diagrams	93
Two-Step Primary Resistor Mode Wiring Diagrams	95
Two-Step Autotransformer Mode Wiring Diagrams	97
Two-Speed Dahlander Mode Wiring Diagrams	99
Two-Speed Pole Changing Mode Wiring Diagrams	101

Overload Mode Wiring Diagrams

Application Diagram with 3-Wire (Impulse) Terminal Strip Control

The following application diagram features a 3-wire (impulse) terminal strip control wiring diagram:

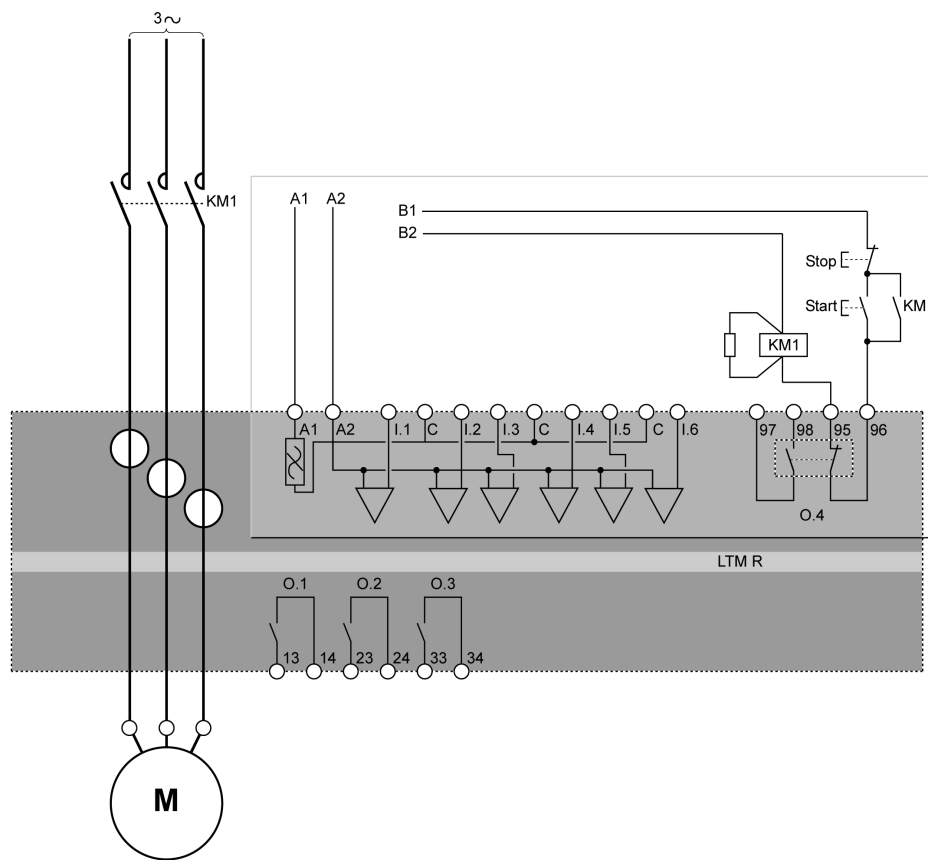

Application Diagram with 2-Wire (Maintained) Terminal Strip Control

The following application diagram features a 2-wire (maintained) terminal strip control wiring diagram:

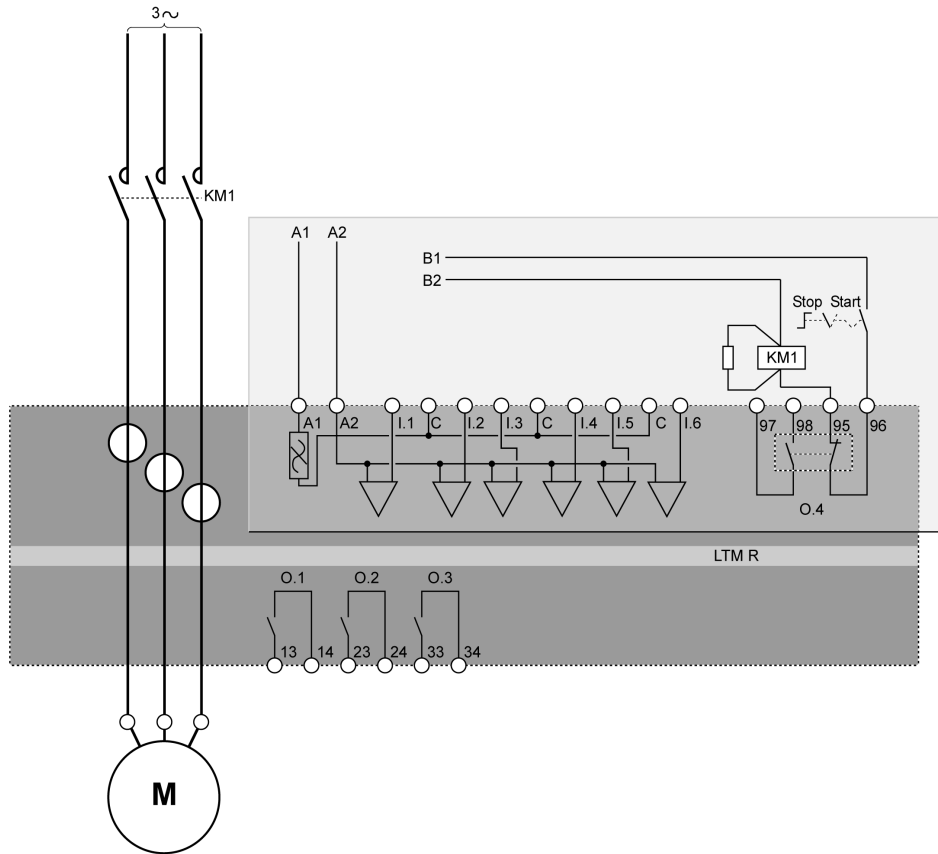

Application Diagram with 3-Wire (Impulse) Terminal Strip Control with Network Control Selectable

The following application diagram features a 3-wire (impulse) terminal strip control with network control selectable wiring diagram:

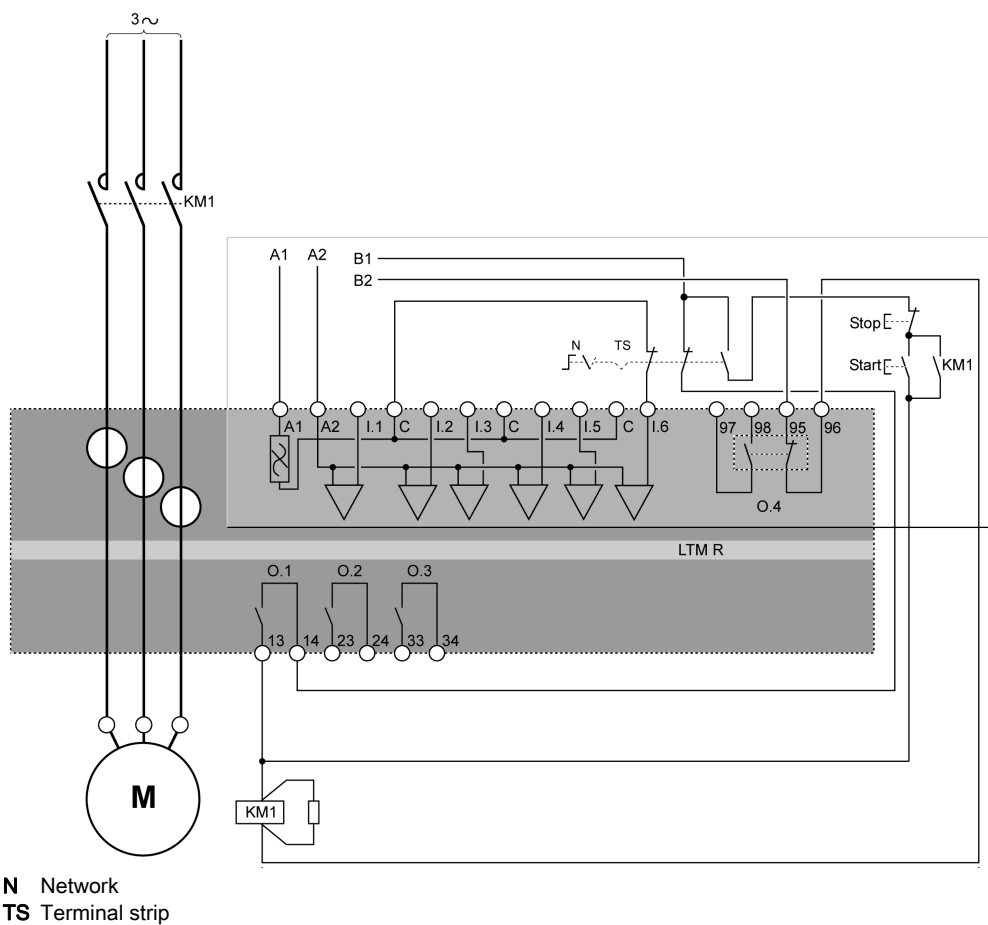

Application Diagram with 2-Wire (Maintained) Terminal Strip Control with Network Control Selectable

The following application diagram features a 2-wire (maintained) terminal strip control with network control selectable wiring diagram:

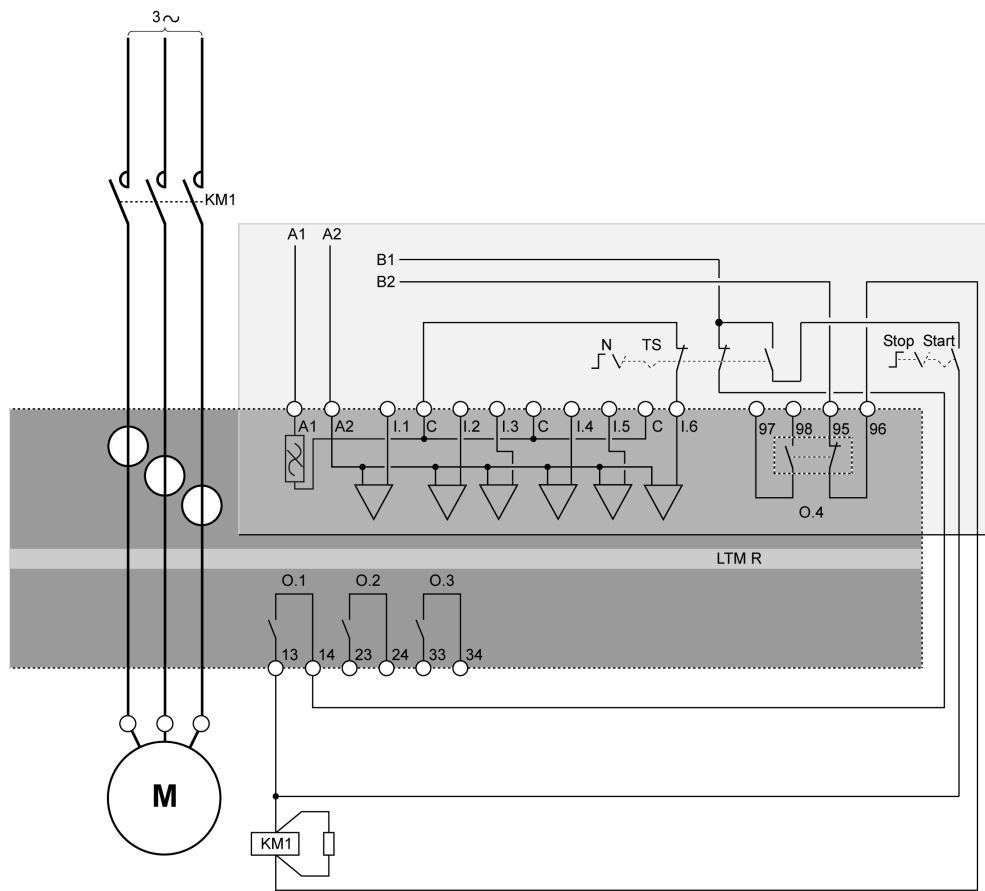

N Network
TS Terminal strip

Independent Mode Wiring Diagrams

Application Diagram with 3-Wire (Impulse) Terminal Strip Control

The following application diagram features a 3-wire (impulse) terminal strip control wiring diagram:

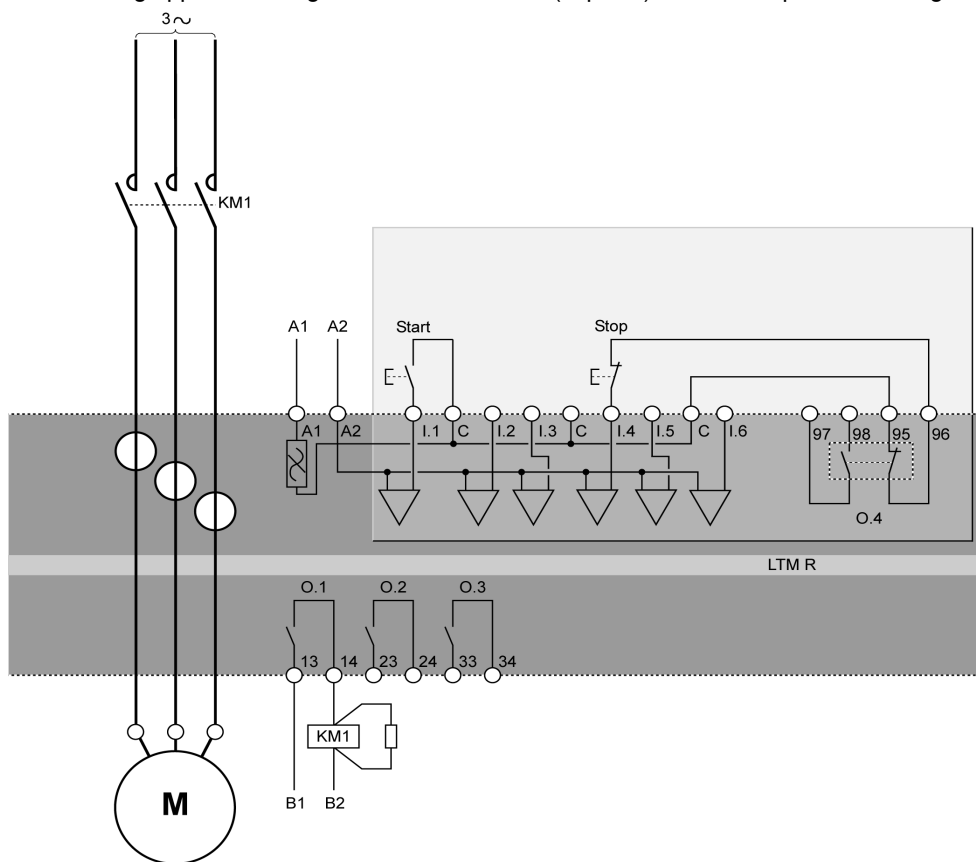

Application Diagram with 2-Wire (Maintained) Terminal Strip Control

The following application diagram features a 2-wire (maintained) terminal strip control wiring diagram:

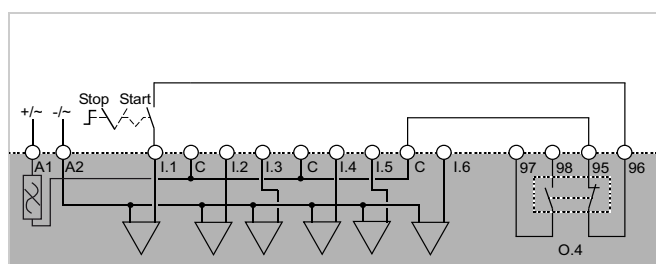

Application Diagram with 3-Wire (Impulse) Terminal Strip Control with Network Control Selectable

The following application diagram features a 3-wire (impulse) terminal strip control with network control selectable wiring diagram:

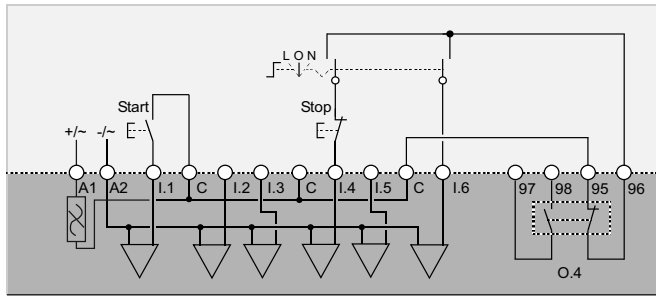

- L** Terminal strip control
- O** Off
- N** Network control

Application Diagram with 2-Wire (Maintained) Terminal Strip Control with Network Control Selectable

The following application diagram features a 2-wire (maintained) terminal strip control with network control selectable wiring diagram:

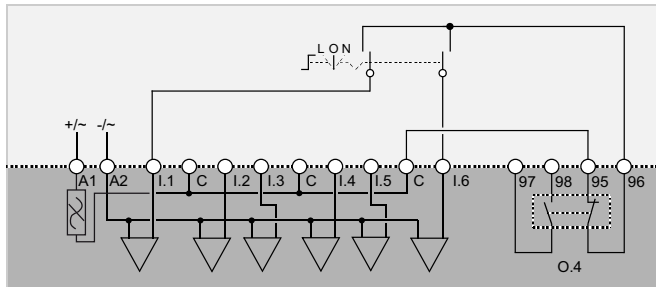

- L** Terminal strip control
- O** Off
- N** Network control

Reverser Mode Wiring Diagrams

Application Diagram with 3-Wire (Impulse) Terminal Strip Control

The following application diagram features a 3-wire (impulse) terminal strip control wiring diagram:

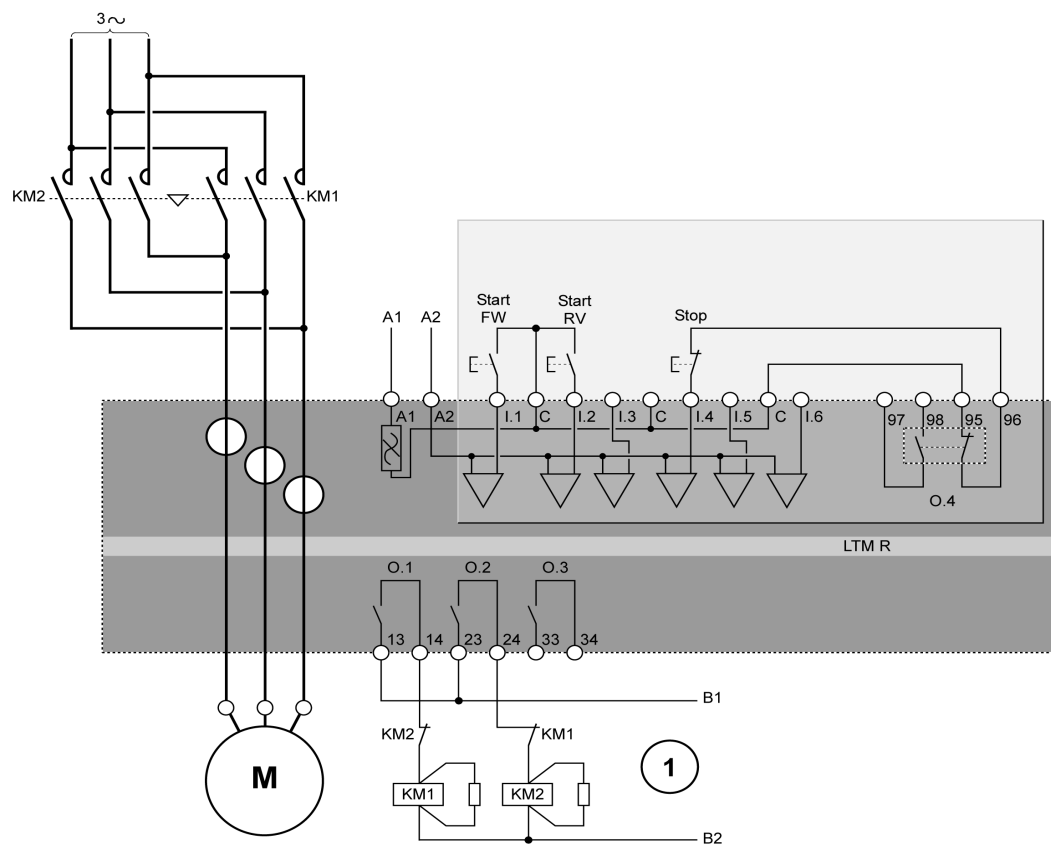

Start FW Start forward

Start RV Start reverse

1 The N.C. interlock contacts KM1 and KM2 are not mandatory because the controller electronically interlocks O.1 and O.2.

Application Diagram with 2-Wire (Maintained) Terminal Strip Control

The following application diagram features a 2-wire (maintained) terminal strip control wiring diagram:

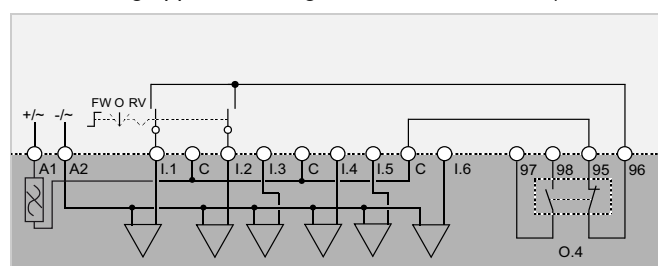

FW Forward

O Off

RV Reverse

Application Diagram with 3-Wire (Impulse) Terminal Strip Control with Network Control Selectable

The following application diagram features a 3-wire (impulse) terminal strip control with network control selectable wiring diagram:

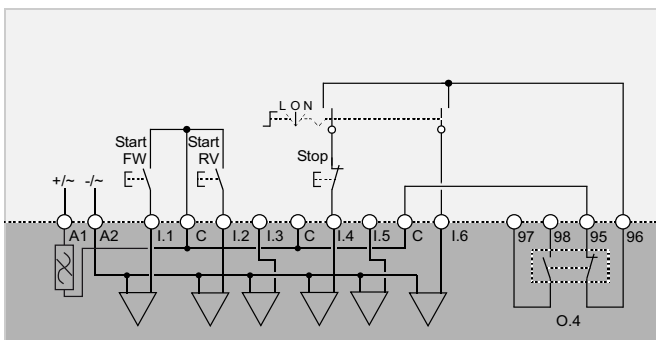

- L** Terminal strip control
- O** Off
- N** Network control
- Start FW** Start forward
- Start RV** Start reverse

Application Diagram with 2-Wire (Maintained) Terminal Strip Control with Network Control Selectable

The following application diagram features a 2-wire (maintained) terminal strip control with network control selectable wiring diagram:

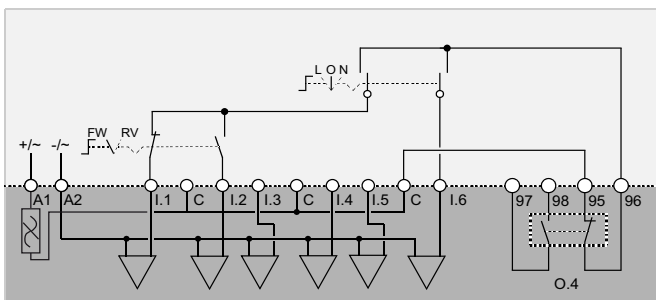

- L** Terminal strip control
- O** Off
- N** Network control
- FW** Forward
- RV** Reverse

Two-Step Wye-Delta Mode Wiring Diagrams

Application Diagram with 3-Wire (Impulse) Terminal Strip Control

The following application diagram features a 3-wire (impulse) terminal strip control wiring diagram:

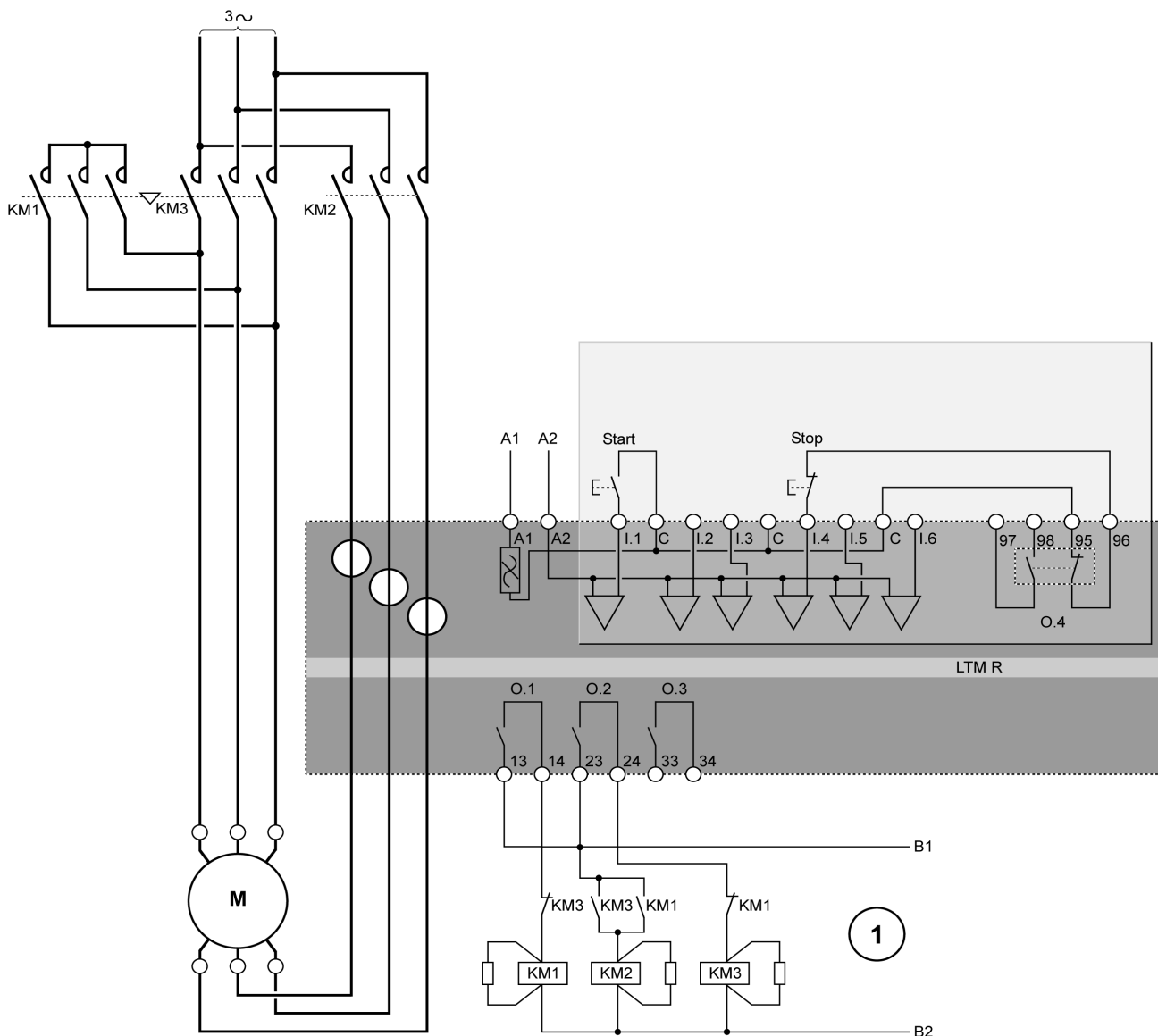

- 1 The N.C. interlock contacts KM1 and KM3 are not mandatory because the controller electronically interlocks O.1 and O.2.

Application Diagram with 2-Wire (Maintained) Terminal Strip Control

The following application diagram features a 2-wire (maintained) terminal strip control wiring diagram:

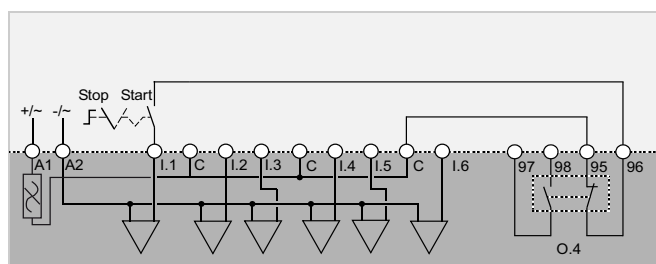

Application Diagram with 3-Wire (Impulse) Terminal Strip Control with Network Control Selectable

The following application diagram features 3-wire (impulse) terminal strip control with network control selectable wiring diagram:

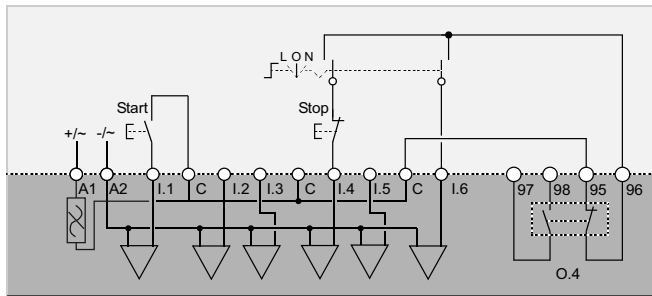

- L** Terminal strip control
- O** Off
- N** Network control

Application Diagram with 2-Wire (Maintained) Terminal Strip Control with Network Control Selectable

The following application diagram features 2-wire (maintained) terminal strip control with network control selectable wiring diagram:

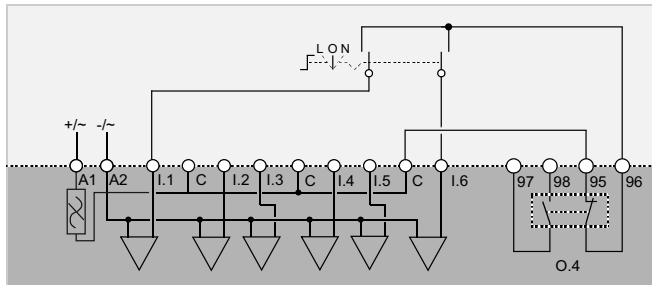

- L** Terminal strip control
- O** Off
- N** Network control

Two-Step Primary Resistor Mode Wiring Diagrams

Application Diagram with 3-Wire (Impulse) Terminal Strip Control

The following application diagram features a 3-wire (impulse) terminal strip control wiring diagram:

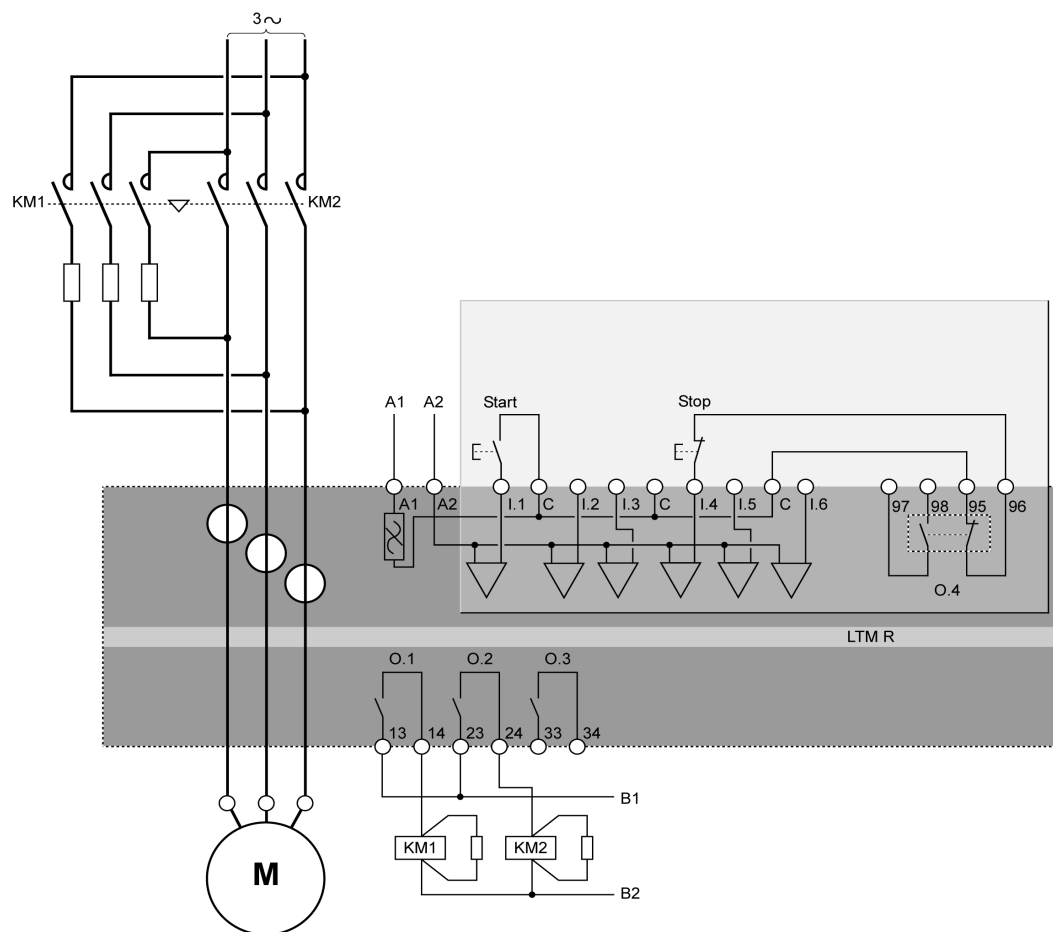

Application Diagram with 2-Wire (Maintained) Terminal Strip Control

The following application diagram features a 2-wire (maintained) terminal strip control wiring diagram:

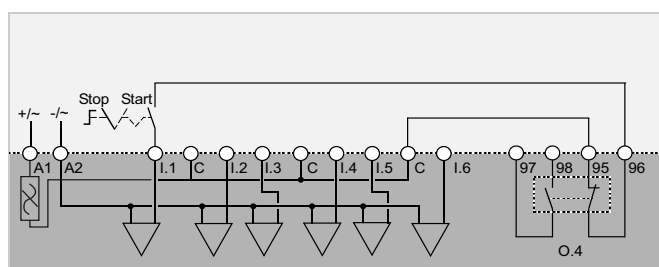

Application Diagram with 3-Wire (Impulse) Terminal Strip Control with Network Control Selectable

The following application diagram features a 3-wire (impulse) terminal strip control with network control selectable wiring diagram:

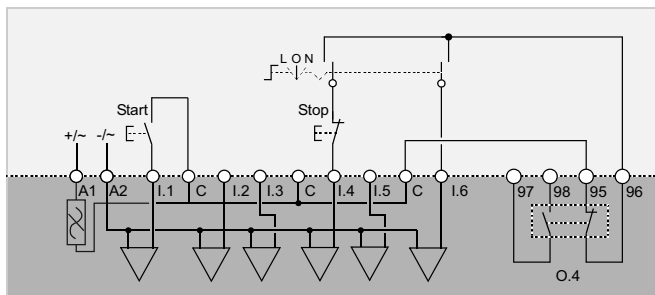

- L** Terminal strip control
- O** Off
- N** Network control

Application Diagram with 2-Wire (Maintained) Terminal Strip Control with Network Control Selectable

The following application diagram features a 2-wire (maintained) terminal strip control with network control selectable wiring diagram:

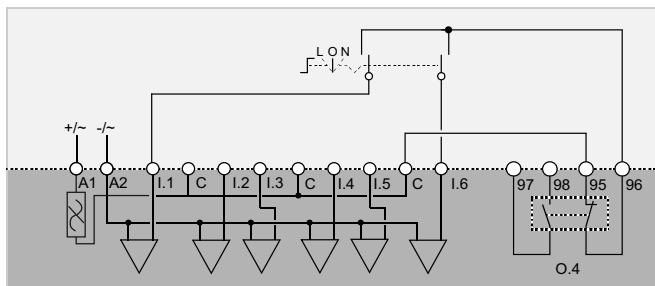

- L** Terminal strip control
- O** Off
- N** Network control

Two-Step Autotransformer Mode Wiring Diagrams

Application Diagram with 3-Wire (Impulse) Terminal Strip Control

The following application diagram features a 3-wire (impulse) terminal strip control wiring diagram:

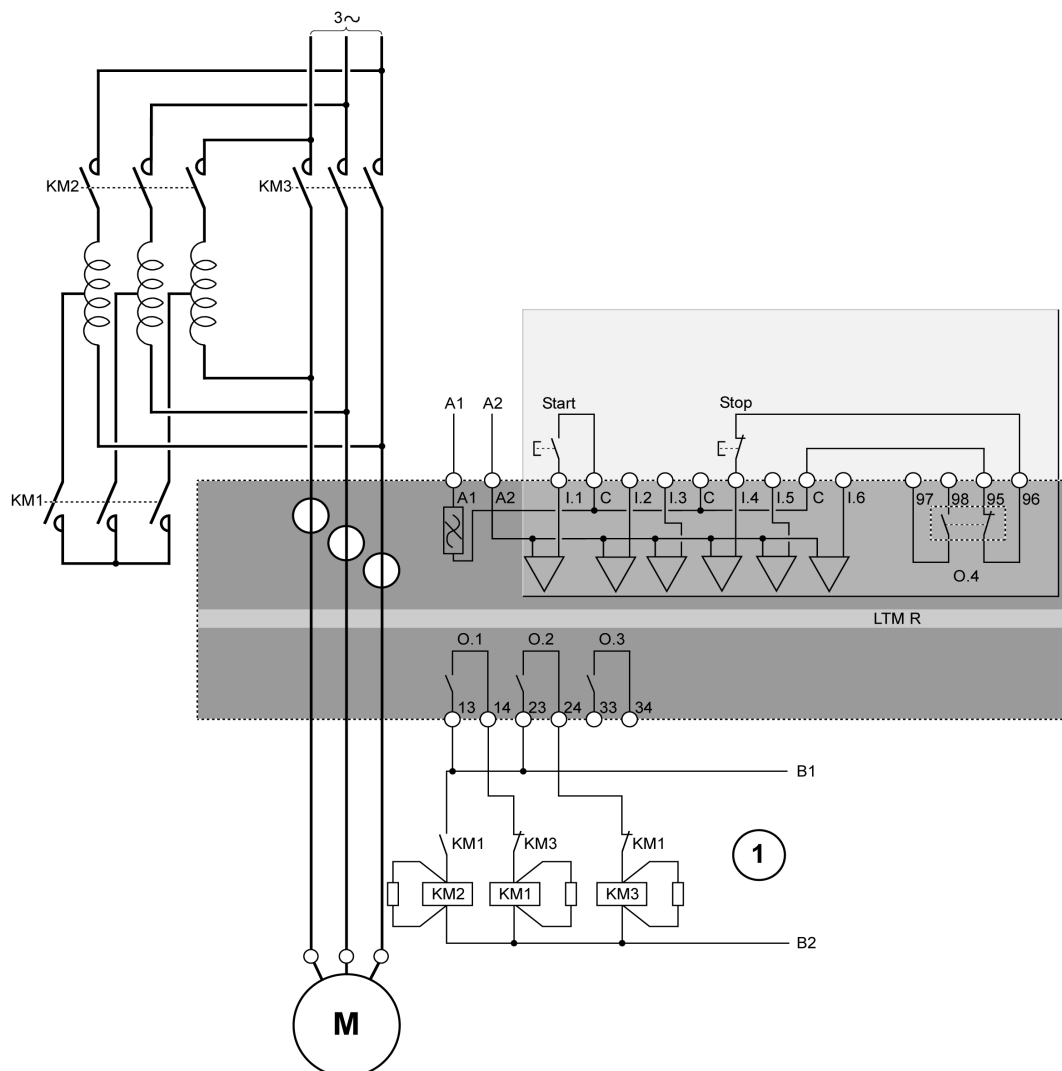

- 1 The N.C. interlock contacts KM1 and KM3 are not mandatory because the controller electronically interlocks O.1 and O.2.

Application Diagram with 2-Wire (Maintained) Terminal Strip Control

The following application diagram features a 2-wire (maintained) terminal strip control wiring diagram:

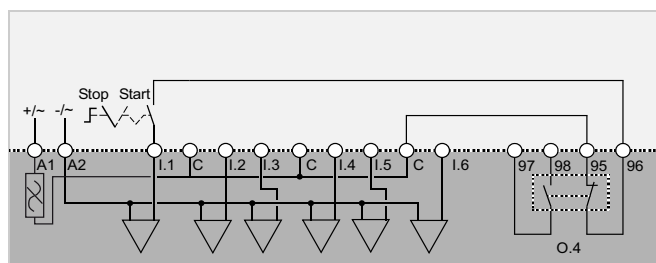

Application Diagram with 3-Wire (Impulse) Terminal Strip Control with Network Control Selectable

The following application diagram features a 3-wire (impulse) terminal strip control with network control selectable wiring diagram:

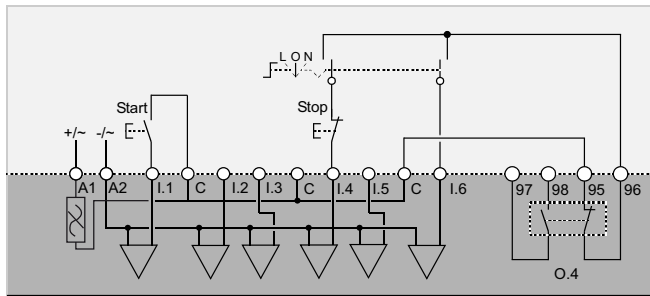

- L** Terminal strip control
- O** Off
- N** Network control

Application Diagram with 2-Wire (Maintained) Terminal Strip Control with Network Control Selectable

The following application diagram features a 2-wire (maintained) terminal strip control with network control selectable wiring diagram:

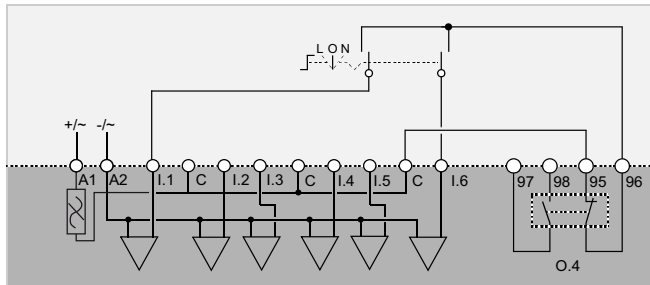

- L** Terminal strip control
- O** Off
- N** Network control

Two-Speed Dahlander Mode Wiring Diagrams

Application Diagram with 3-Wire (Impulse) Terminal Strip Control

The following application diagram features a 3-wire (impulse) terminal strip control wiring diagram:

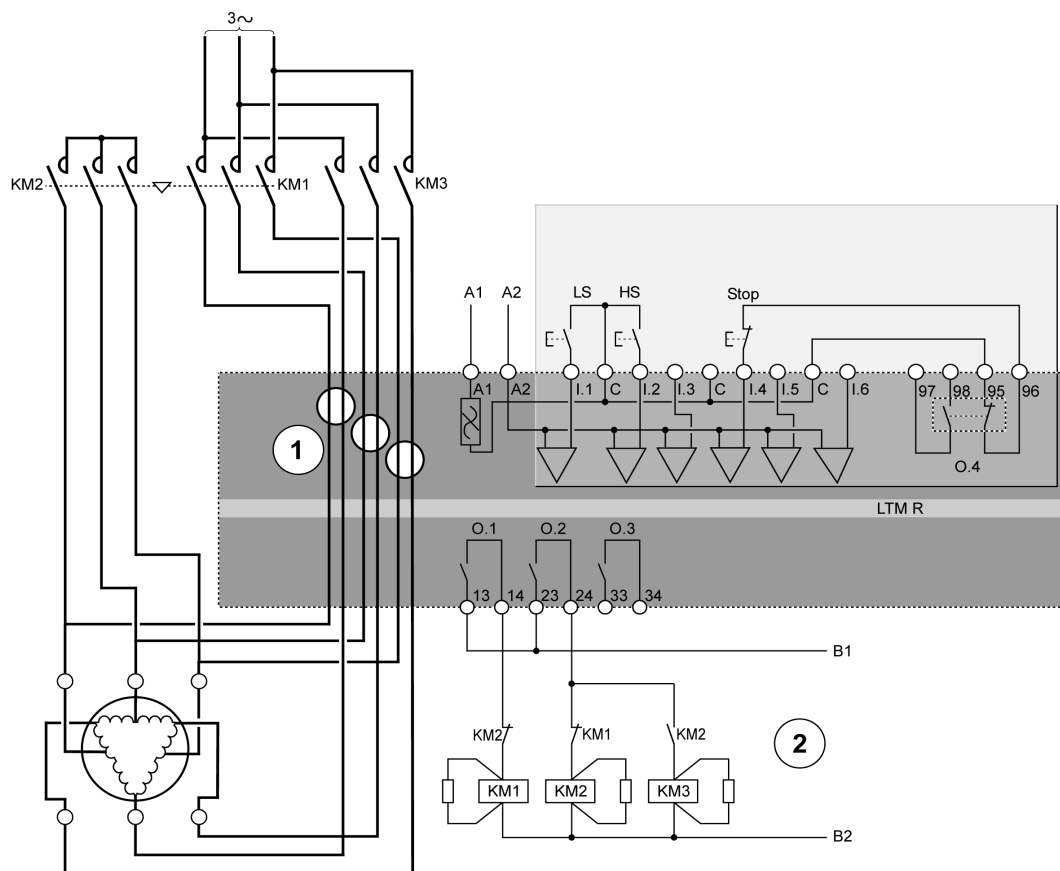

LS Low speed

HS High speed

- 1 A Dahlander application requires 2 sets of wires passing through the CT windows. The controller can also be placed upstream of the contactors. If this is the case, and if the Dahlander motor is used in variable torque mode, all the wires downstream of the contactors must be the same size.
- 2 The N.C. interlock contacts KM1 and KM2 are not mandatory because the controller electronically interlocks O.1 and O.2.

Application Diagram with 2-Wire (Maintained) Terminal Strip Control

The following application diagram features a 2-wire (maintained) terminal strip control wiring diagram:

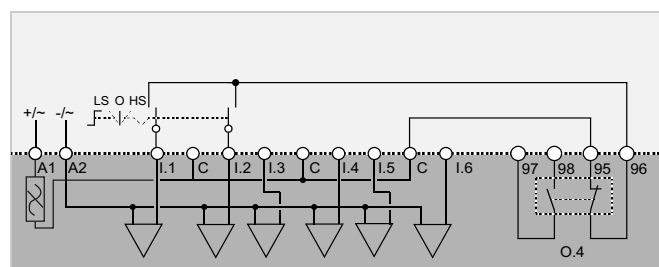

LS Low speed

O Off

HS High speed

Application Diagram with 3-Wire (Impulse) Terminal Strip Control with Network Control Selectable

The following application diagram features a 3-wire (impulse) terminal strip control with network control selectable wiring diagram:

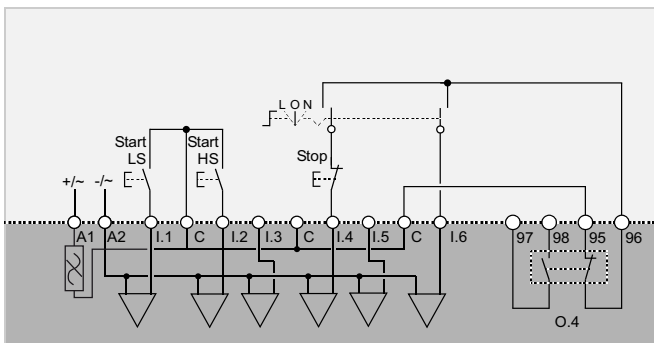

- L** Terminal strip control
- O** Off
- N** Network control
- LS** Low speed
- HS** High speed

Application Diagram with 2-Wire (Maintained) Terminal Strip Control with Network Control Selectable

The following application diagram features a 2-wire (maintained) terminal strip control with network control selectable wiring diagram:

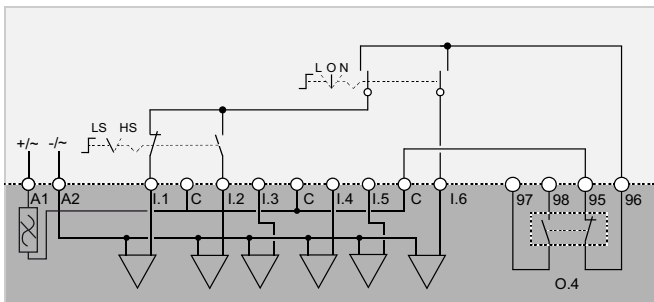

- L** Terminal strip control
- O** Off
- N** Network control
- LS** Low speed
- HS** High speed

Two-Speed Pole Changing Mode Wiring Diagrams

Application Diagram with 3-Wire (Impulse) Terminal Strip Control

The following application diagram features a 3-wire (impulse) terminal strip control wiring diagram:

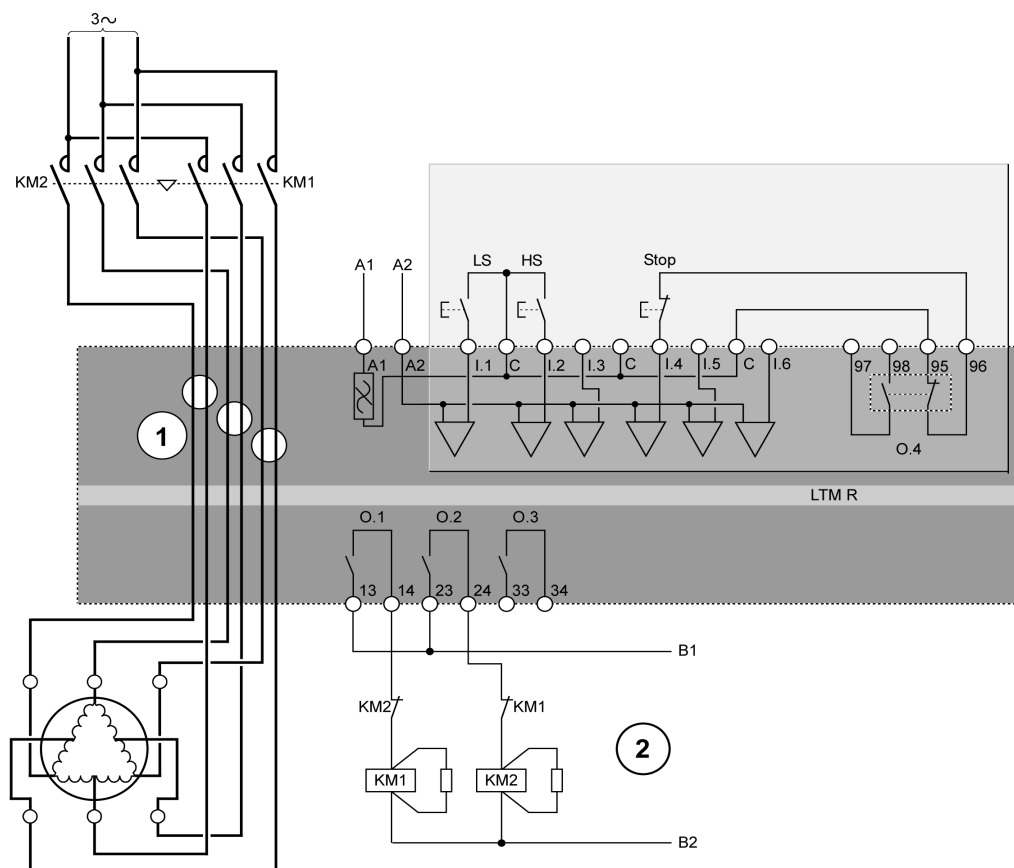

LS Low speed

HS High speed

- 1 A pole-changing application requires two sets of wires passing through the CT windows. The controller can also be placed upstream of the contactors. If this is the case, all the wires downstream of the contactors must be the same size.
- 2 The N.C. interlock contacts KM1 and KM2 are not mandatory because the controller firmware interlocks O.1 and O.2.

Application Diagram with 2-Wire (Maintained) Terminal Strip Control

The following application diagram features a 2-wire (maintained) terminal strip control wiring diagram:

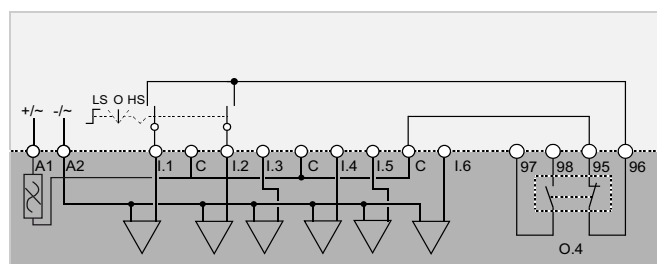

LS Low speed

O Off

HS High speed

Application Diagram with 3-Wire (Impulse) Terminal Strip Control with Network Control Selectable

The following application diagram features a 3-wire (impulse) terminal strip control with network control selectable wiring diagram:

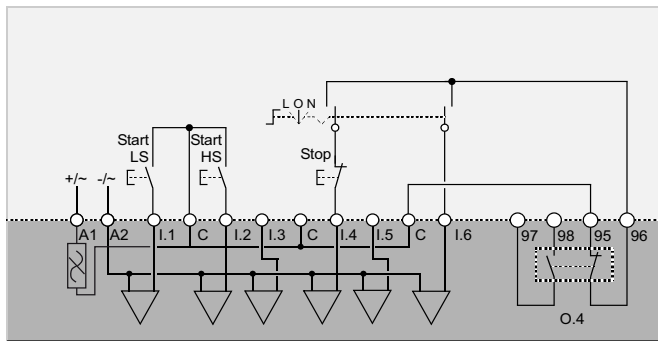

- L** Terminal strip control
- O** Off
- N** Network control
- Start LS** Start Low speed
- Start HS** Start High speed

Application Diagram with 2-Wire (Maintained) Terminal Strip Control with Network Control Selectable

The following application diagram features a 2-wire (maintained) terminal strip control with network control selectable wiring diagram:

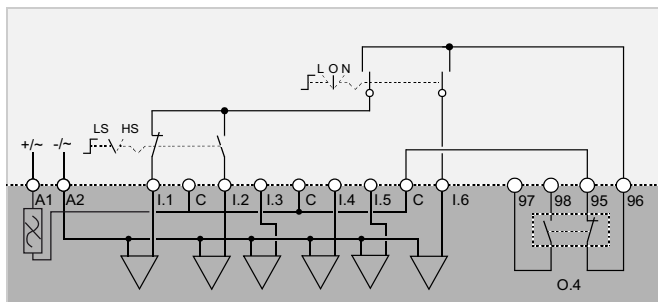

- L** Terminal strip control
- O** Off
- N** Network control
- LS** Low speed
- HS** High speed

Section B.2

NEMA Format Wiring Diagrams

Overview

This section contains the wiring diagrams corresponding to the five pre-configured operating modes:

Overload	Monitoring of the motor load where control (start/stop) of the motor load is achieved by a mechanism other than the controller
Independent	Direct-on-line (across-the-line) full-voltage non-reversing motor starting applications
Reverser	Direct-on-line (across-the-line) full-voltage reversing motor starting applications
Two-Step	Reduced voltage starting motor applications, including: <ul style="list-style-type: none"> ● Wye-Delta ● Open Transition Primary Resistor ● Open Transition Autotransformer
Two-Speed	Two-speed motor applications for motor types, including: <ul style="list-style-type: none"> ● Dahlander (consequent pole) ● Pole Changer

Each application is described individually, with:

One complete application diagram (including power and control)	3-wire (impulse) terminal strip control
Three partial diagrams (control logic input wiring variants)	2-wire (maintained) terminal strip control
	3-wire (impulse) terminal strip control with network control selectable
	2-wire (maintained) terminal strip control with network control selectable

What Is in This Section?

This section contains the following topics:

Topic	Page
Overload Mode Wiring Diagrams	104
Independent Mode Wiring Diagrams	108
Reverser Mode Wiring Diagrams	110
Two-Step Wye-Delta Mode Wiring Diagrams	112
Two-Step Primary Resistor Mode Wiring Diagrams	114
Two-Step Autotransformer Mode Wiring Diagrams	116
Two-Speed Mode Wiring Diagrams: Single Winding (Consequent Pole)	118
Two-Speed Mode Wiring Diagrams: Separate Winding	120

Overload Mode Wiring Diagrams

Application Diagram with 3-Wire (Impulse) Terminal Strip Control

The following application diagram features a 3-wire (impulse) terminal strip control wiring diagram:

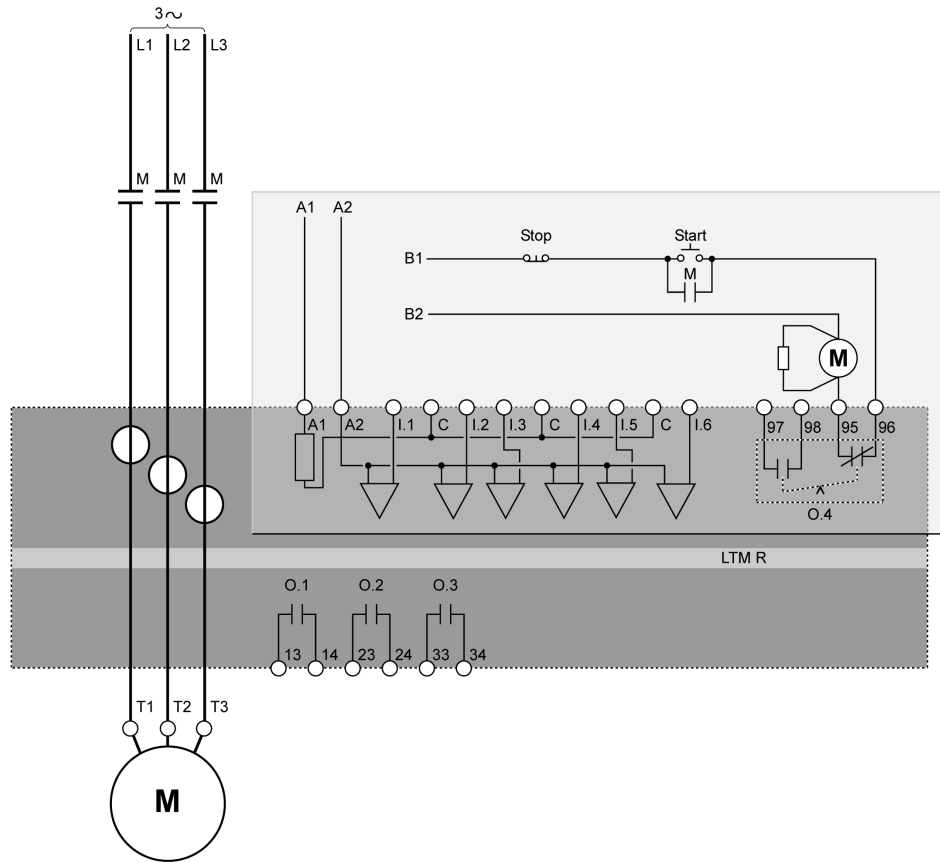

Application Diagram with 2-Wire (Maintained) Terminal Strip Control

The following application diagram features a 2-wire (maintained) terminal strip control wiring diagram:

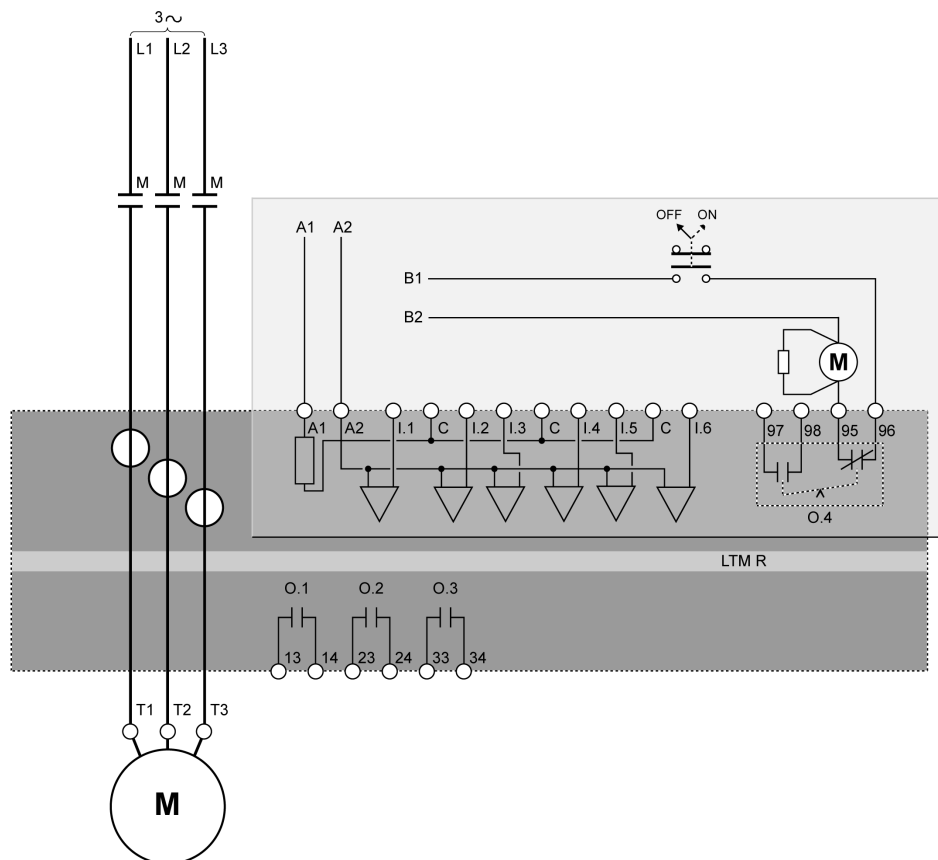

Application Diagram with 3-Wire (Impulse) Terminal Strip Control with Network Control Selectable

The following application diagram features a 3-wire (impulse) terminal strip control with network control selectable wiring diagram:

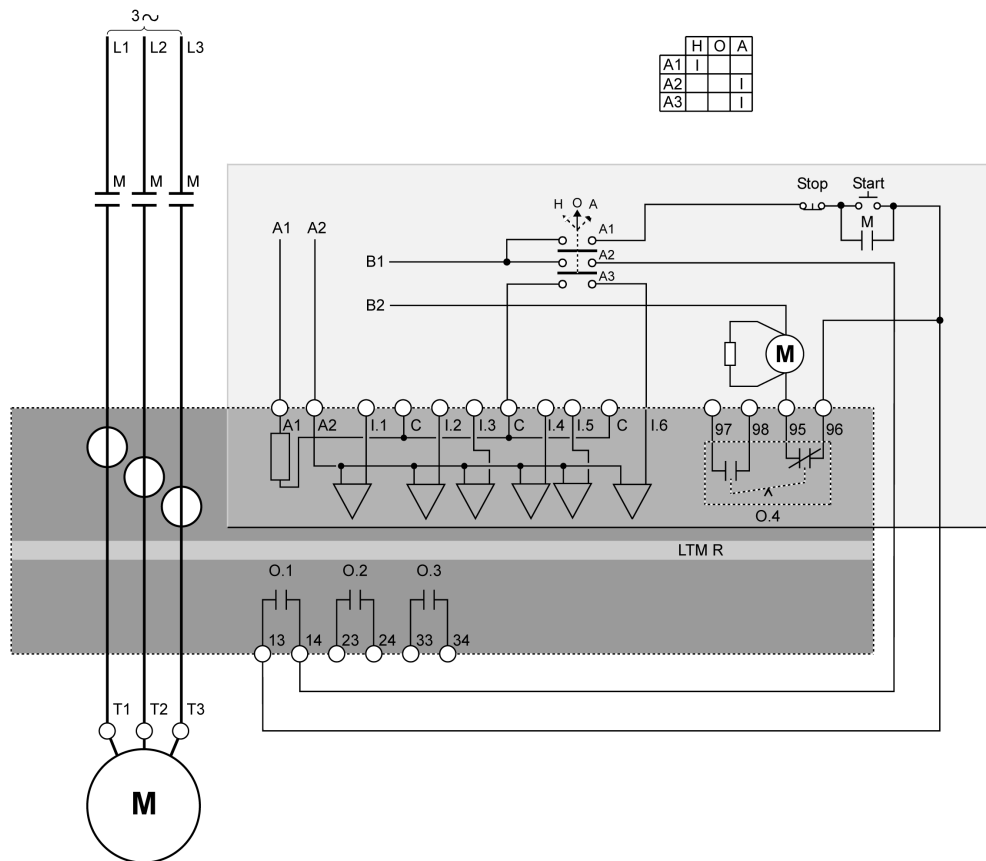

- H** Hand (Terminal strip control)
- O** Off
- A** Automatic (Network control)

Application Diagram with 2-Wire (Maintained) Terminal Strip Control with Network Control Selectable

The following application diagram features a 2-wire (maintained) terminal strip control with network control selectable wiring diagram:

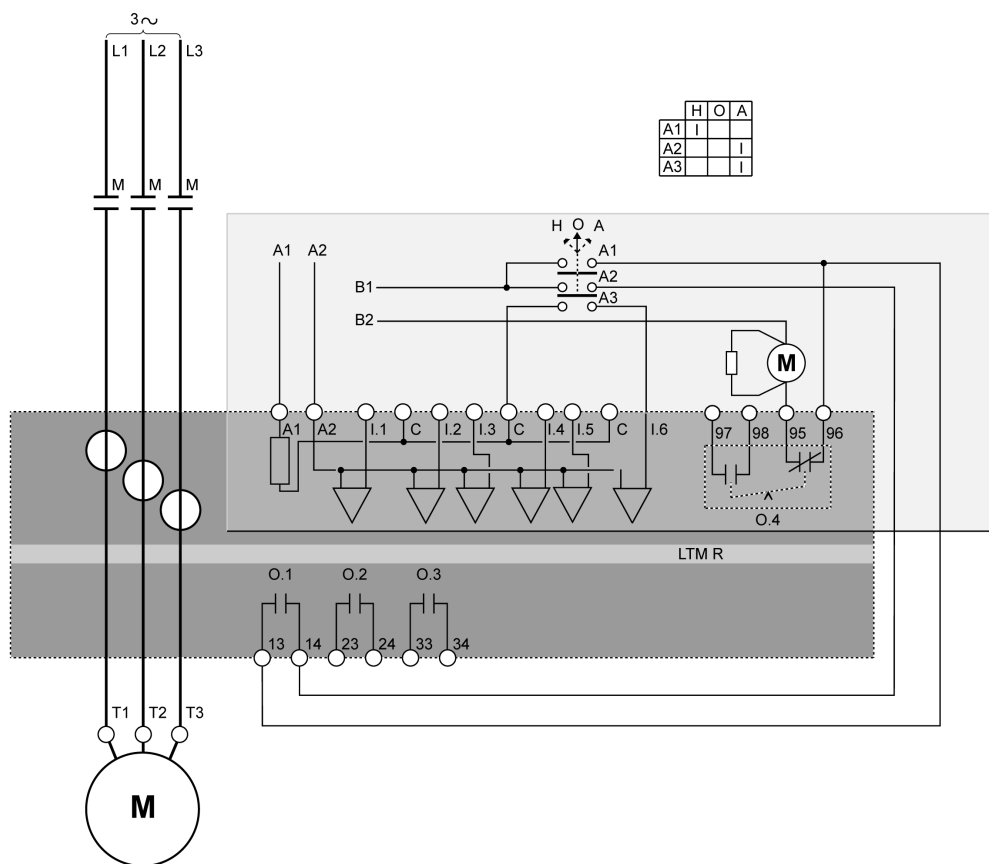

- H Hand (Terminal strip control)
- O Off
- A Automatic (Network control)

Independent Mode Wiring Diagrams

Application Diagram with 3-Wire (Impulse) Terminal Strip Control

The following application diagram features a 3-wire (impulse) terminal strip control wiring diagram:

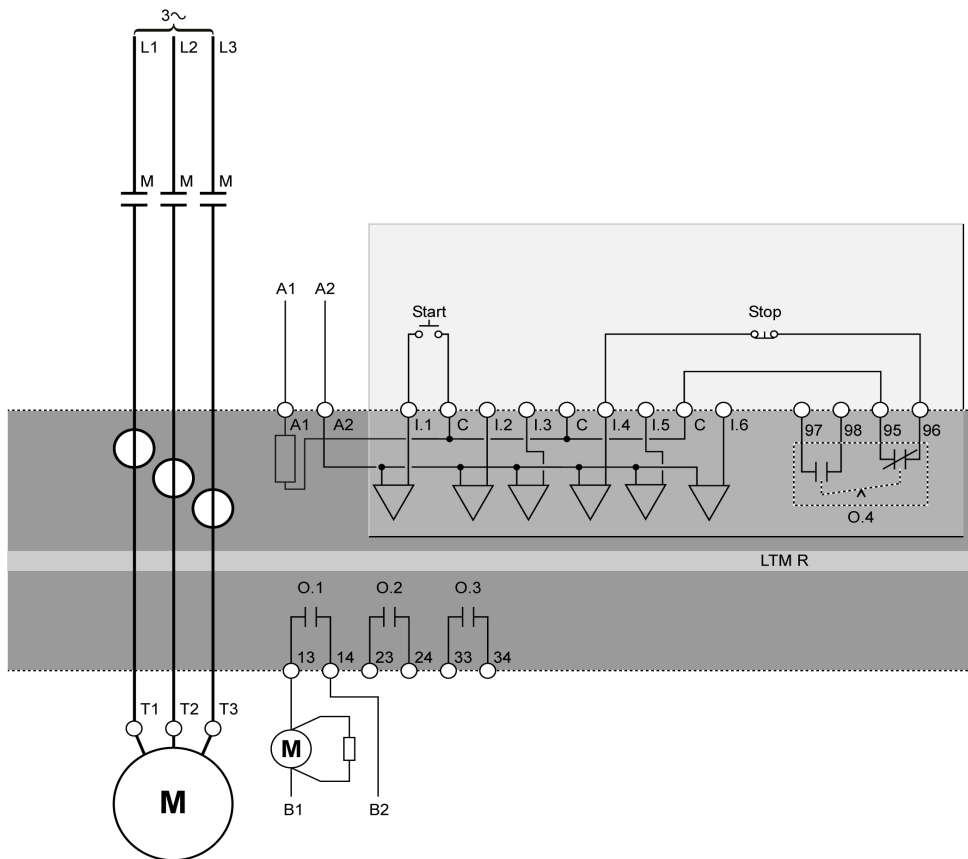

Application Diagram with 2-Wire (Maintained) Terminal Strip Control

The following application diagram features a 2-wire (maintained) terminal strip control wiring diagram:

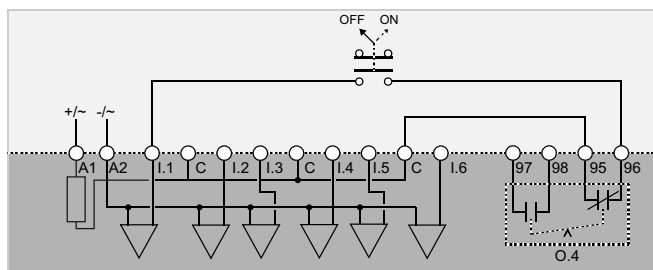

Application Diagram with 3-Wire (Impulse) Terminal Strip Control with Network Control Selectable

The following application diagram features a 3-wire (impulse) terminal strip control with network control selectable wiring diagram:

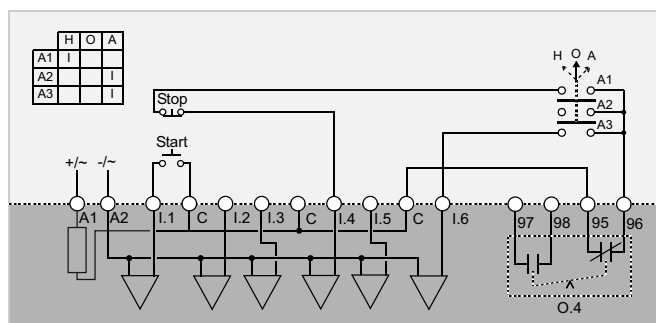

- H Hand (Terminal strip control)
- O Off
- A Automatic (Network control)

Application Diagram with 2-Wire (Maintained) Terminal Strip Control with Network Control Selectable

The following application diagram features a 2-wire (maintained) terminal strip control with network control selectable wiring diagram:

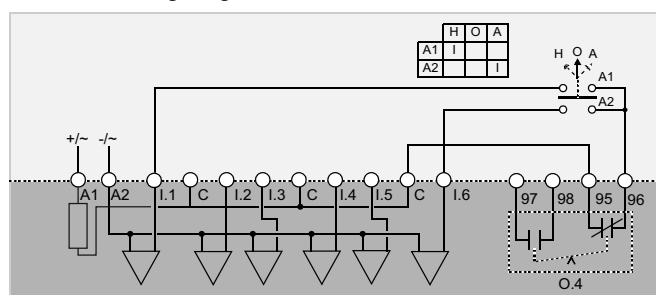

- H Hand (Terminal strip control)
- O Off
- A Automatic (Network control)

Reverser Mode Wiring Diagrams

Application Diagram with 3-Wire (Impulse) Terminal Strip Control

The following application diagram features a 3-wire (impulse) terminal strip control wiring diagram:

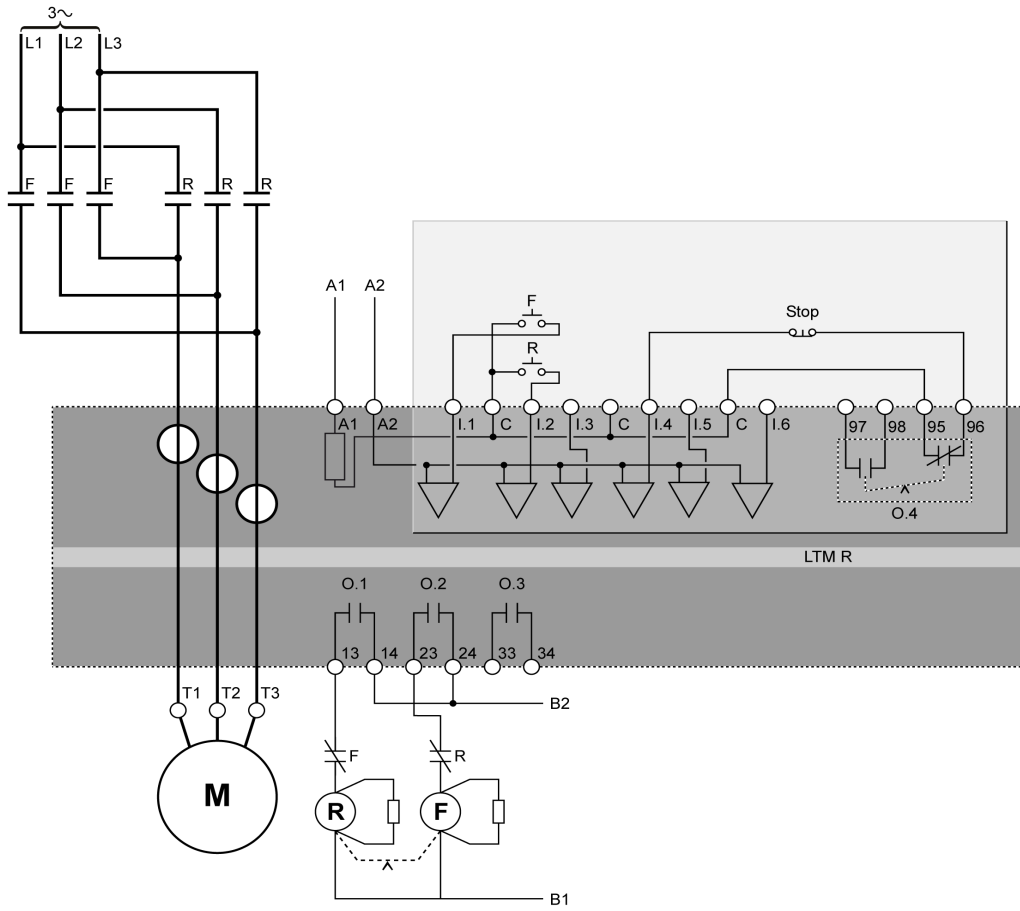

F Forward
R Reverse

Application Diagram with 2-Wire (Maintained) Terminal Strip Control

The following application diagram features a 2-wire (maintained) terminal strip control wiring diagram:

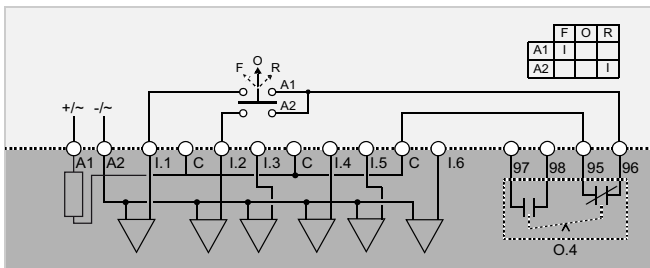

F Forward
O Off
R Reverse

Application Diagram with 3-Wire (Impulse) Terminal Strip Control with Network Control Selectable

The following application diagram features a 3-wire (impulse) terminal strip control with network control selectable wiring diagram:

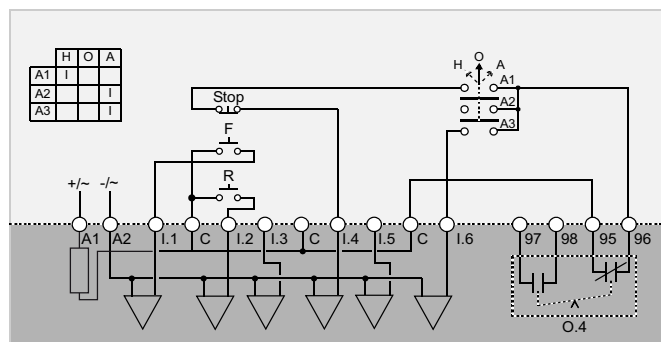

- F** Forward
- R** Reverse
- H** Hand (Terminal strip control)
- O** Off
- A** Automatic (Network control)

Application Diagram with 2-Wire (Maintained) Terminal Strip Control with Network Control Selectable

The following application diagram features a 2-wire (maintained) terminal strip control with network control selectable wiring diagram:

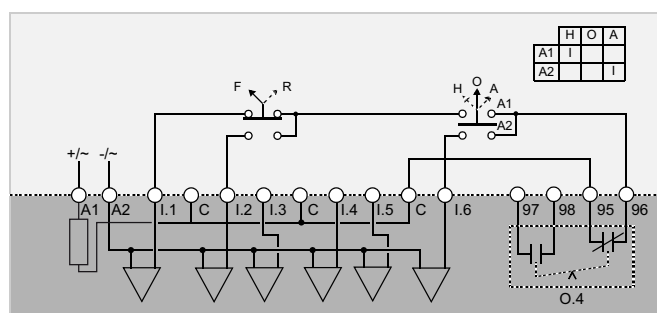

- F** Forward
- R** Reverse
- H** Hand (Terminal strip control)
- O** Off
- A** Automatic (Network control)

Two-Step Wye-Delta Mode Wiring Diagrams

Application Diagram with 3-Wire (Impulse) Terminal Strip Control

The following application diagram features a 3-wire (impulse) terminal strip control wiring diagram:

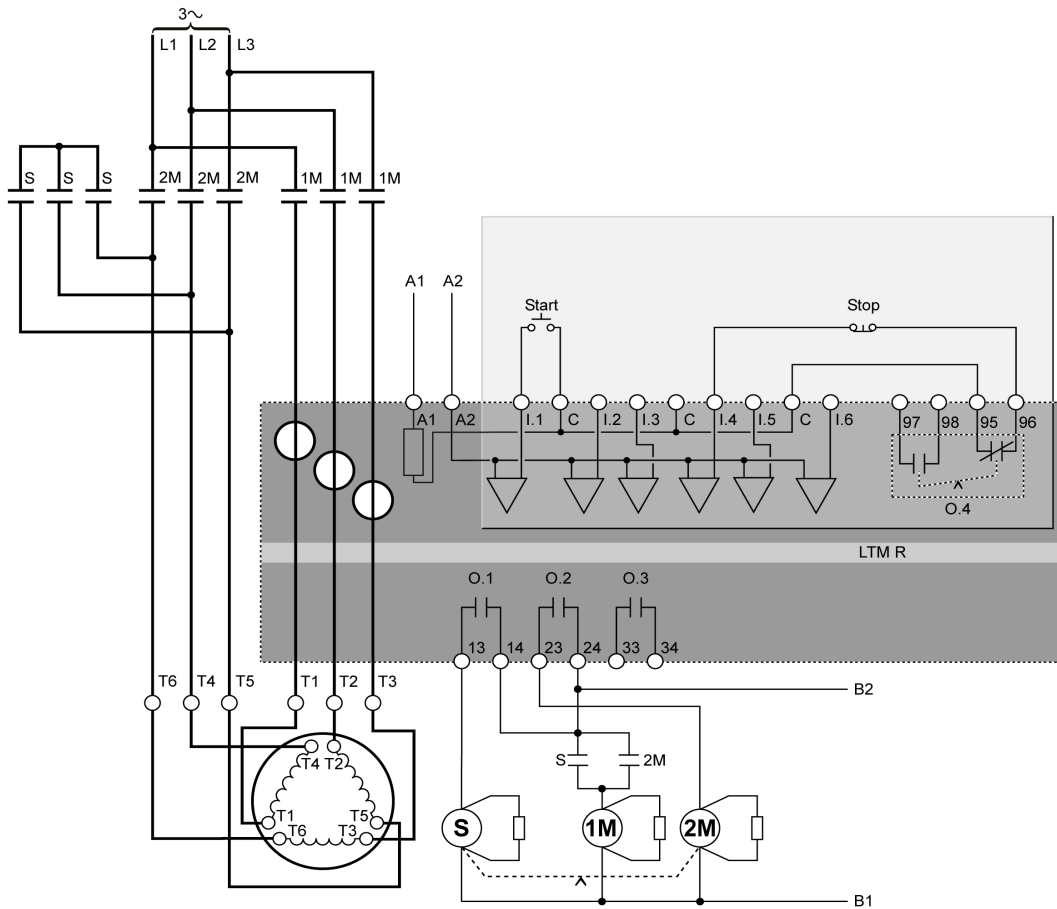

Application Diagram with 2-Wire (Maintained) Terminal Strip Control

The following application diagram features a 2-wire (maintained) terminal strip control wiring diagram:

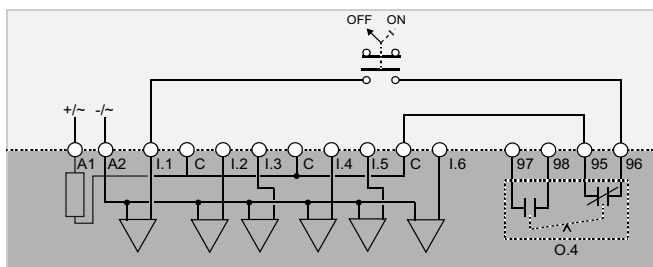

Application Diagram with 3-Wire (Impulse) Terminal Strip Control with Network Control Selectable

The following application diagram features 3-wire (impulse) terminal strip control with network control selectable wiring diagram:

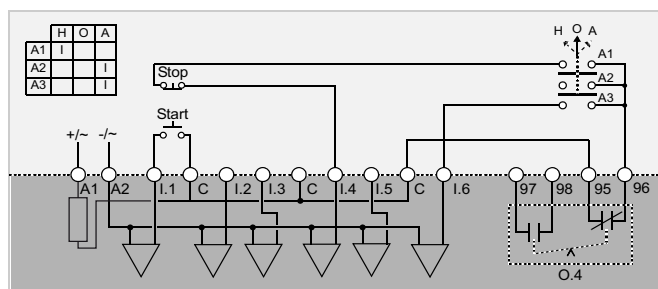

- H Hand (Terminal strip control)
- O Off
- A Automatic (Network control)

Application Diagram with 2-Wire (Maintained) Terminal Strip Control with Network Control Selectable

The following application diagram features 2-wire (maintained) terminal strip control with network control selectable wiring diagram:

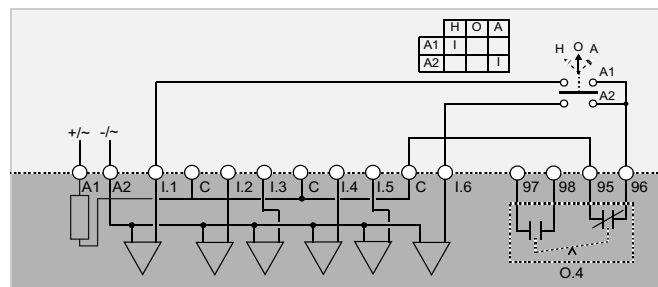

- H Hand (Terminal strip control)
- O Off
- A Automatic (Network control)

Two-Step Primary Resistor Mode Wiring Diagrams

Application Diagram with 3-Wire (Impulse) Terminal Strip Control

The following application diagram features a 3-wire (impulse) terminal strip control wiring diagram:

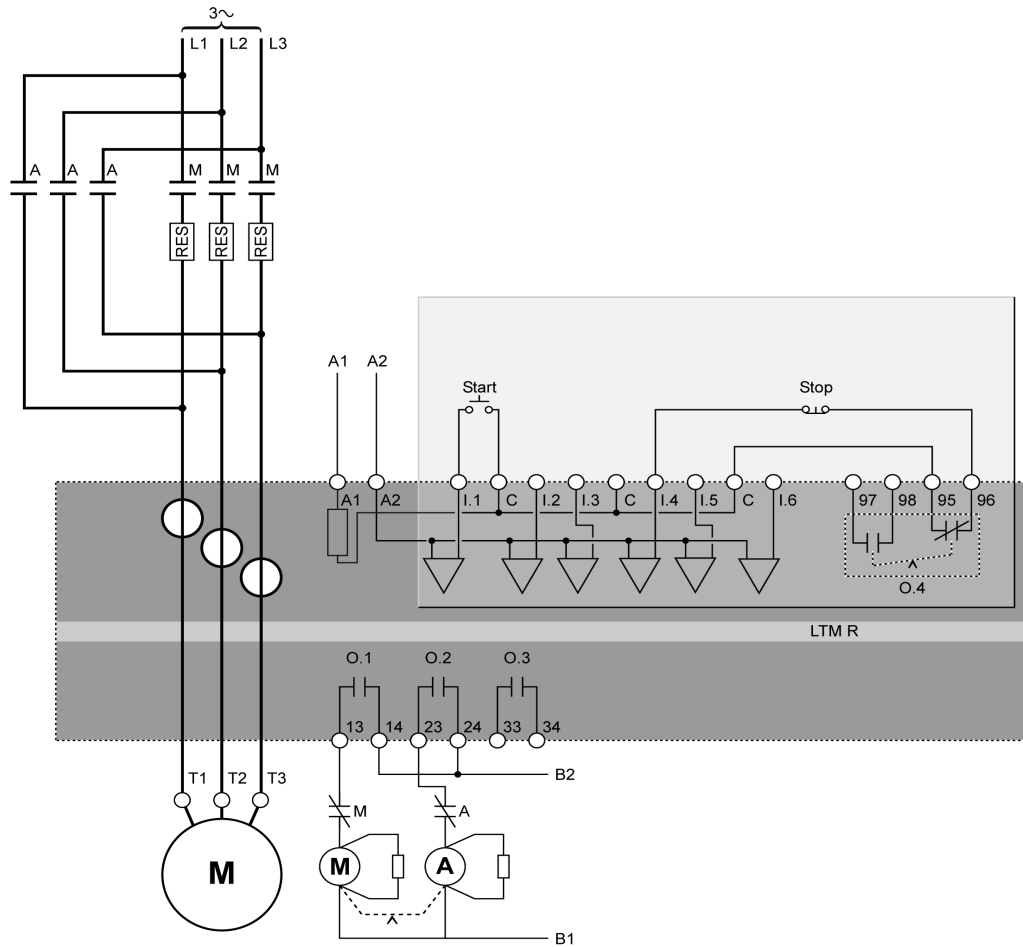

Application Diagram with 2-Wire (Maintained) Terminal Strip Control

The following application diagram features a 2-wire (maintained) terminal strip control wiring diagram:

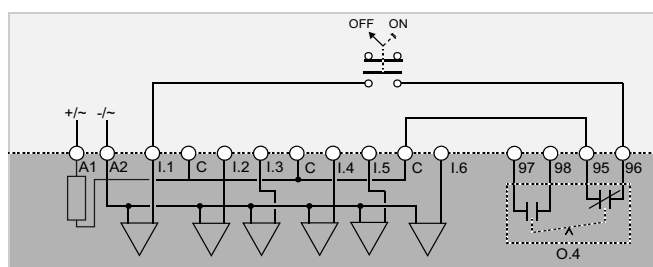

Application Diagram with 3-Wire (Impulse) Terminal Strip Control with Network Control Selectable

The following application diagram features a 3-wire (impulse) terminal strip control with network control selectable wiring diagram:

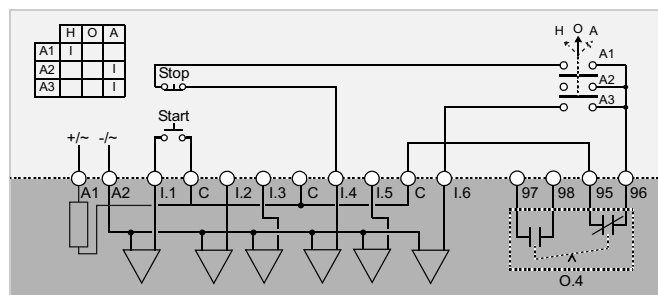

- H Hand (Terminal strip control)
- O Off
- A Automatic (Network control)

Application Diagram with 2-Wire (Maintained) Terminal Strip Control with Network Control Selectable

The following application diagram features a 2-wire (maintained) terminal strip control with network control selectable wiring diagram:

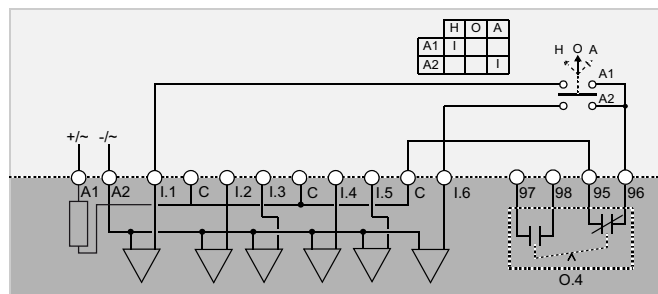

- H Hand (Terminal strip control)
- O Off
- A Automatic (Network control)

Two-Step Autotransformer Mode Wiring Diagrams

Application Diagram with 3-Wire (Impulse) Terminal Strip Control

The following application diagram features a 3-wire (impulse) terminal strip control wiring diagram:

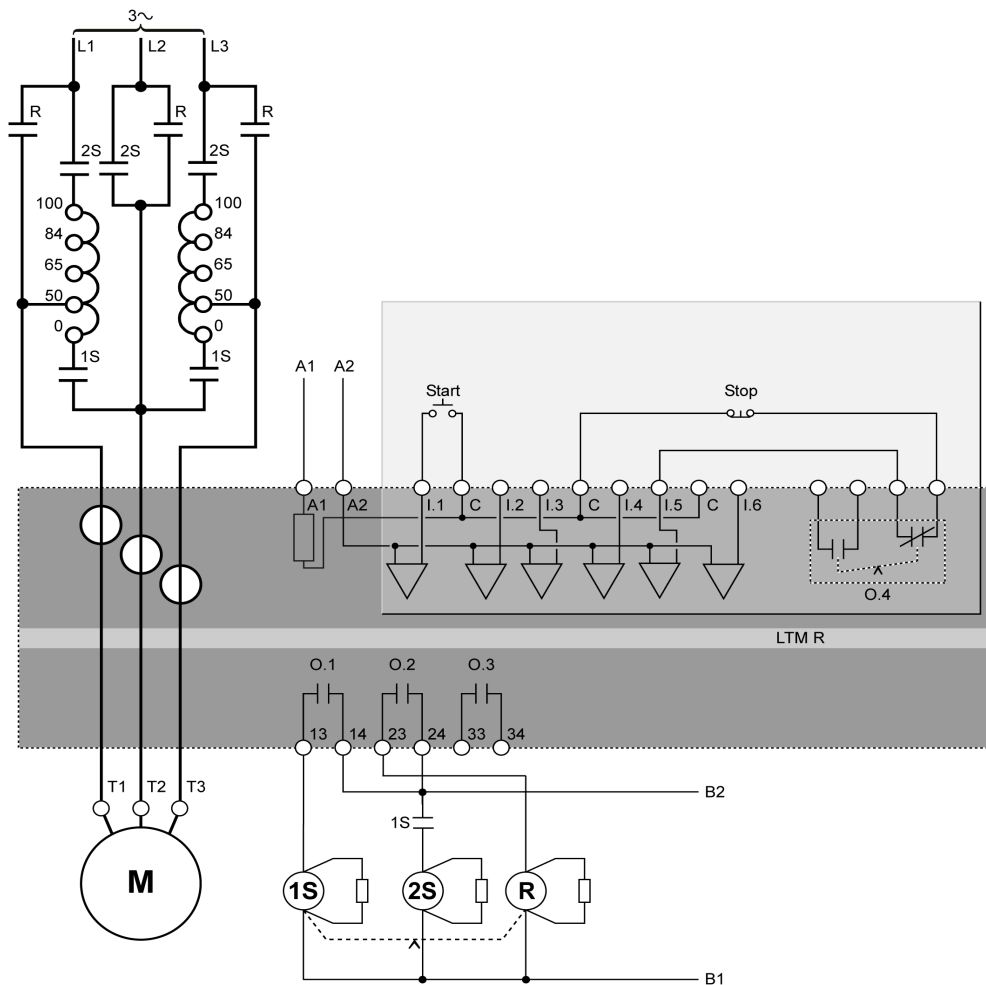

Application Diagram with 2-Wire (Maintained) Terminal Strip Control

The following application diagram features a 2-wire (maintained) terminal strip control wiring diagram:

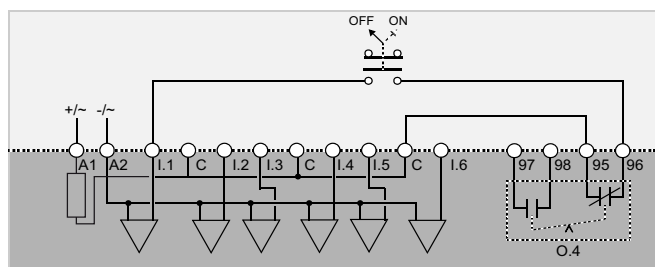

Application Diagram with 3-Wire (Impulse) Terminal Strip Control with Network Control Selectable

The following application diagram features a 3-wire (impulse) terminal strip control with network control selectable wiring diagram:

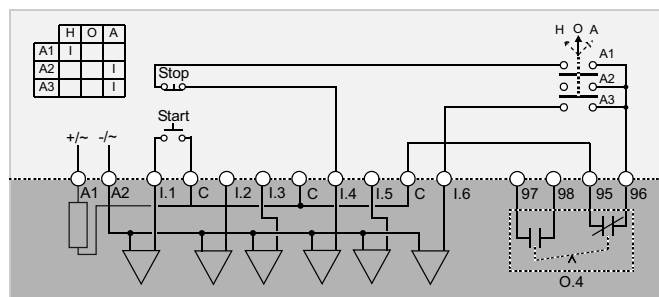

- H Hand (Terminal strip control)
- O Off
- A Automatic (Network control)

Application Diagram with 2-Wire (Maintained) Terminal Strip Control with Network Control Selectable

The following application diagram features a 2-wire (maintained) terminal strip control with network control selectable wiring diagram:

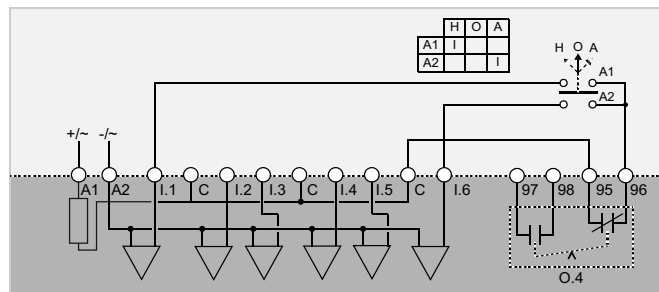

- H Hand (Terminal strip control)
- O Off
- A Automatic (Network control)

Two-Speed Mode Wiring Diagrams: Single Winding (Consequent Pole)

Application Diagram with 3-Wire (Impulse) Terminal Strip Control

The following application diagram features a 3-wire (impulse) terminal strip control wiring diagram:

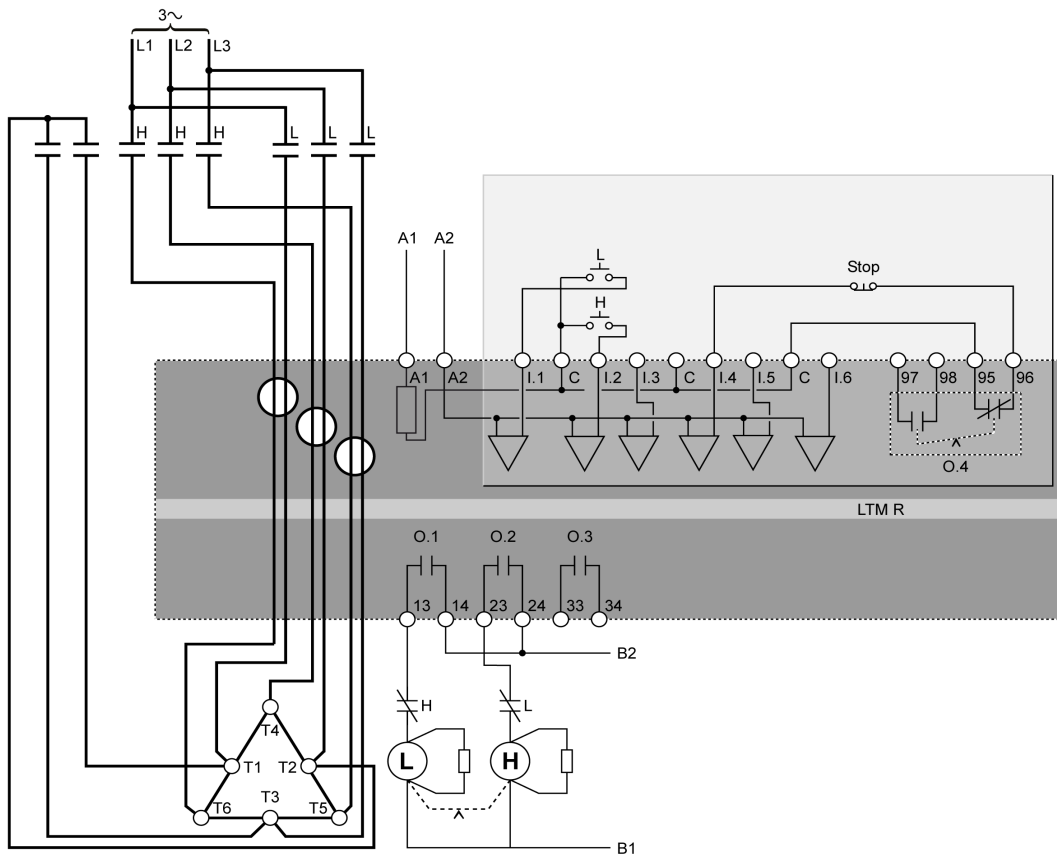

- L Low
- H High

Application Diagram with 2-Wire (Maintained) Terminal Strip Control

The following application diagram features a 2-wire (maintained) terminal strip control wiring diagram:

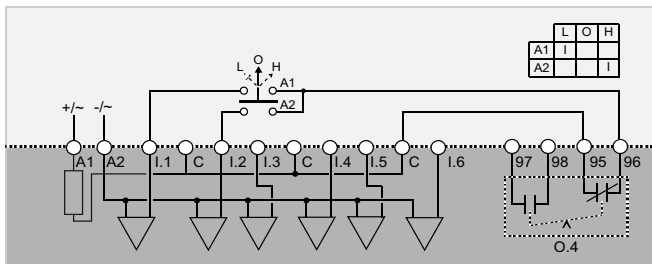

- L Low speed
- O Off
- H High speed

Application Diagram with 3-Wire (Impulse) Terminal Strip Control with Network Control Selectable

The following application diagram features a 3-wire (impulse) terminal strip control with network control selectable wiring diagram:

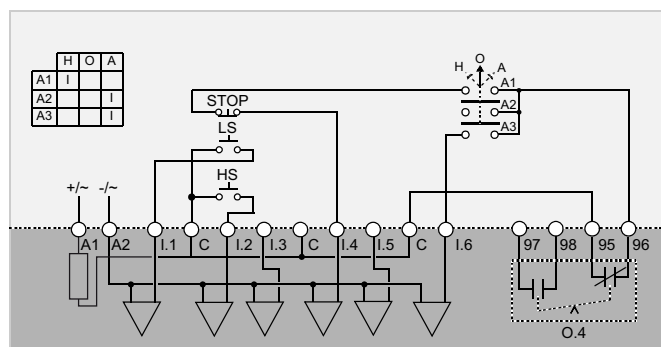

- LS** Low speed
- HS** High speed
- H** Hand (Terminal strip control)
- O** Off
- A** Automatic (Network control)

Application Diagram with 2-Wire (Maintained) Terminal Strip Control with Network Control Selectable

The following application diagram features a 2-wire (maintained) terminal strip control with network control selectable wiring diagram:

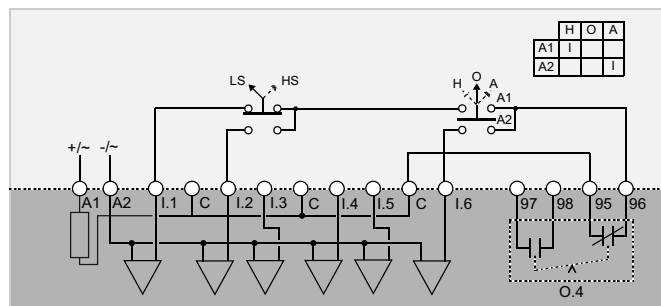

- LS** Low speed
- HS** High speed
- H** Hand (Terminal strip control)
- O** Off
- A** Automatic (Network control)

Two-Speed Mode Wiring Diagrams: Separate Winding

Application Diagram with 3-Wire (Impulse) Terminal Strip Control

The following application diagram features a 3-wire (impulse) terminal strip control wiring diagram:

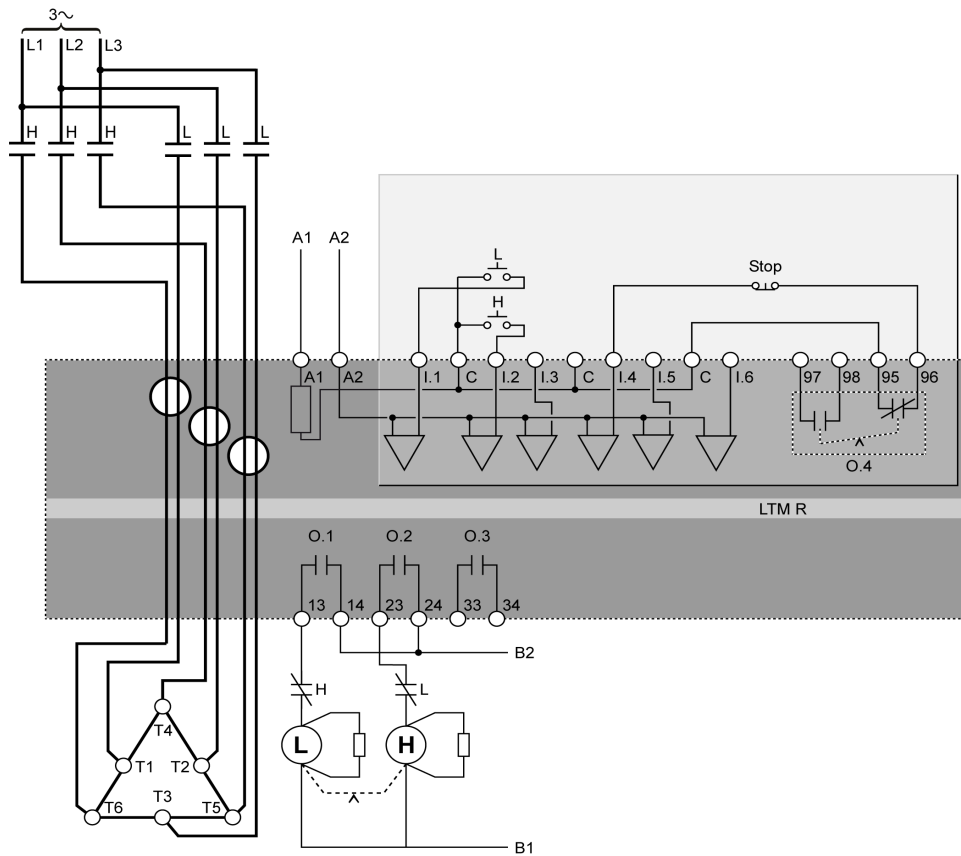

- L Low
- H High

Application Diagram with 2-Wire (Maintained) Terminal Strip Control

The following application diagram features a 2-wire (maintained) terminal strip control wiring diagram:

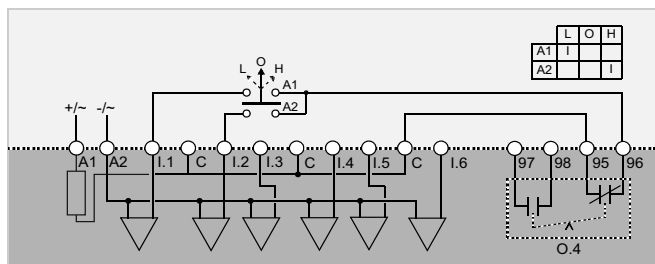

- L Low speed
- O Off
- H High speed

Application Diagram with 3-Wire (Impulse) Terminal Strip Control with Network Control Selectable

The following application diagram features a 3-wire (impulse) terminal strip control with network control selectable wiring diagram:

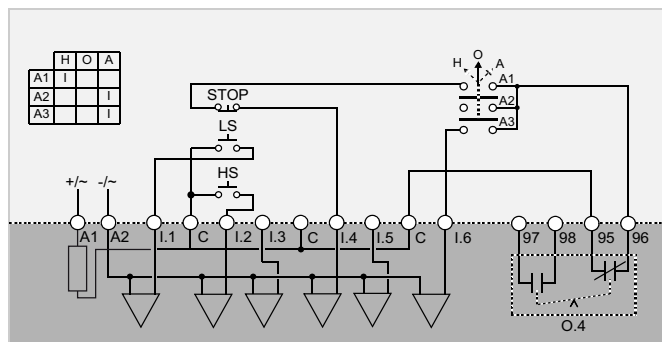

- LS** Low speed
- HS** High speed
- H** Hand (Terminal strip control)
- O** Off
- A** Automatic (Network control)

Application Diagram with 2-Wire (Maintained) Terminal Strip Control with Network Control Selectable

The following application diagram features a 2-wire (maintained) terminal strip control with network control selectable wiring diagram:

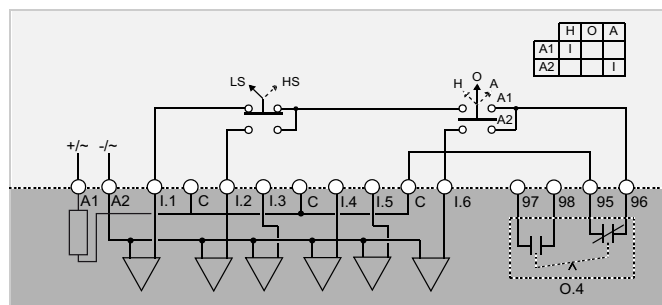

- LS** Low speed
- HS** High speed
- H** Hand (Terminal strip control)
- O** Off
- A** Automatic (Network control)



A

active power

Also known as *real power*, active power is the rate of producing, transferring or using electrical energy. It is measured in watts (W) and often expressed in kilowatts (kW) or megawatts (MW).

analog

Describes inputs (e.g. temperature) or outputs (e.g. motor speed) that can be set to a range of values. Contrast with discrete.

apparent power

The product of current and voltage, apparent power consists of both active power and reactive power. It is measured in volt-amperes and often expressed in kilovolt-amperes (kVA) or megavolt-amperes (MVA).

C

CANopen

An open industry standard protocol used on the internal communication bus. The protocol allows the connection of any standard CANopen device to the island bus.

CT

current transformer.

D

definite time

A variety of TCC or TVC where the initial magnitude of the trip time delay remains a constant, and does not vary in response to changes in the value of the measured quantity (e.g. current). Contrast with inverse thermal.

device

In the broadest terms, any electronic unit that can be added to a network. More specifically, a programmable electronic unit (e.g. PLC, numeric controller or robot) or I/O card.

DeviceNet

DeviceNet is a low-level, connection-based network protocol that is based on CAN, a serial bus system without a defined application layer. DeviceNet, therefore, defines a layer for the industrial application of CAN.

DIN

Deutsches Institut für Normung. The European organization that organizes the creation and maintenance of dimensional and engineering standards.

DIN rail

A steel mounting rail, made pursuant to DIN standards (typically 35 mm wide), that allows for easier "snap-on" mounting of IEC electrical devices, including the LTMR controller and the expansion module. Contrast with screw mounting of devices to a control panel by drilling and tapping holes.

discrete

Describes inputs (e.g. switches) or outputs (e.g. coils) that can be only *On* or *Off*. Contrast with analog.

DPST

double-pole/single-throw. A switch that connects or disconnects two circuit conductors in a single branch circuit. A DPST switch has 4 terminals, and is the equivalent of two single-pole/single-throw switches controlled by a single mechanism, as depicted below:

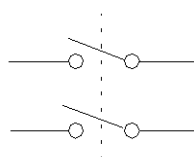

E**endian setting (big endian)**

'big endian' means that the high-order byte/word of the number is stored in memory at the lowest address, and the low-order byte/word at the highest address (the big end comes first).

endian setting (little endian)

'little endian' means that the low-order byte/word of the number is stored in memory at the lowest address, and the high-order byte/word at the highest address (the little end comes first).

EtherNet/IP

(Ethernet Industrial Protocol) is an industrial application protocol built on TCP/IP and CIP protocols. It is mainly used on automated networks, it defines network devices as network objects as to allow the communication between industrial control system and their components; (programmable automation controller, programmable logic controller, I/O systems).

F**FLC**

full load current. Also known as *rated current*. The current the motor will draw at the rated voltage and rated load. The LTMR controller has two FLC settings: FLC1 (Motor Full Load Current Ratio) and FLC2 (Motor High Speed Full Load Current Ratio), each set as a percentage of FLC max.

FLC1

Motor Full Load Current Ratio. FLC parameter setting for low or single speed motors.

FLC2

Motor High Speed Full Load Current Ratio. FLC parameter setting for high-speed motors.

FLCmax

Full Load Current Max. Peak current parameter.

FLCmin

Minimum Full Load Current. The smallest amount of motor current the LTMR controller will support. This value is determined by the LTMR controller model.

H**hysteresis**

A value—added to lower limit threshold settings or subtracted from upper limit threshold settings—that retards the response of the LTMR controller before it stops measuring the duration of faults and warnings.

I**inverse thermal**

A variety of TCC where the initial magnitude of the trip time delay is generated by a thermal model of the motor and varies in response to changes in the value of the measured quantity (e.g. current). Contrast with definite time.

M**Modbus**

Modbus is the name of the master-slave/client-server serial communications protocol developed by Modicon (now Schneider Automation, Inc.) in 1979, which has since become a standard network protocol for industrial automation.

N**nominal power**

Motor Nominal Power. Parameter for the power a motor will produce at rated voltage and rated current.

nominal voltage

Motor Nominal Voltage. Parameter for rated voltage.

NTC	<i>negative temperature coefficient.</i> Characteristic of a thermistor—a thermally sensitive resistor—whose resistance increases as its temperature falls, and whose resistance decreases as its temperature rises.
NTC analog	Type of RTD.
P	
PLC	<i>programmable logic controller.</i>
power factor	Also called <i>cosine phi</i> (or ϕ), power factor represents the absolute value of the ratio of active power to apparent power in AC power systems.
PROFIBUS DP	An open bus system that uses an electrical network based on a shielded 2-wire line or an optical network based on a fiber-optic cable.
PT100	Type of RTD.
PTC	<i>positive temperature coefficient.</i> Characteristic of a thermistor—a thermally sensitive resistor—whose resistance increases as its temperature rises, and whose resistance decreases as its temperature falls.
PTC analog	Type of RTD.
PTC binary	Type of RTD.
R	
reset time	Time between a sudden change in the monitored quantity (e.g. current) and the switching of the output relay.
rms	<i>root mean square.</i> A method of calculating average AC current and average AC voltage. Because AC current and AC voltage are bi-directional, the arithmetic average of AC current or voltage always equals 0.
RTD	<i>resistance temperature detector.</i> A thermistor (thermal resistor sensor) used to measure the temperature of the motor. Required by the LTMR controller's Motor Temp Sensor motor protection function.
T	
TCC	<i>trip curve characteristic.</i> The type of delay used to trip the flow of current in response to a fault condition. As implemented in the LTMR controller, all motor protection function trip time delays are definite time, except for the Thermal Overload function, which also offers inverse thermal trip time delays.
TVC	<i>trip voltage characteristic.</i> The type of delay used to trip the flow of voltage in response to a fault condition. As implemented by the LTMR controller and the expansion module, all TVCs are definite time.



A

- auto restart
 - delayed restart timeout, 78
 - immediate restart timeout, 78
- automatic fault reset
 - attempts group1, 72
 - attempts group2, 72
 - attempts group3, 72
 - timeout group1, 72
 - timeout group2, 72
 - timeout group3, 72

C

- command
 - clear all, 48
 - self test, 62, 62
- commissioning
 - first power-up, 48
 - introduction, 46
 - verify configuration, 55
 - verify wiring, 53
- communication configuration
 - via engineering tool enable, 73
 - via HMI keyboard enable, 73
- config via
 - HMI engineering tool enable, 47
 - HMI keypad enable, 47
 - HMI network port enable, 47
- contactor rating, 70
- control remote
 - channel setting, 80
- controller
 - system config required, 48
- current phase imbalance
 - fault enable, 75
 - fault threshold, 75
 - fault timeout running, 75
 - fault timeout starting, 75
 - warning enable, 75
 - warning threshold, 75
- current phase loss
 - fault enable, 75
 - fault timeout, 75
 - warning enable, 75
- current phase reversal
 - fault enable, 75

D

- definite time
 - long start fault timeout, 74
- diagnostic
 - fault enable, 72
 - warning enable, 72

display enable

- active power, 81
- average current, 80
- average current ratio, 80
- average voltage, 81
- control mode, 80
- current phase imbalance, 81
- date, 80
- frequency, 81
- ground current, 81
- inputs/outputs, 80
- L1 current, 80
- L1 current ratio, 81
- L1L2 voltage, 81
- L2 current, 80
- L2 current ratio, 81
- L2L3 voltage, 81
- L3 current, 80
- L3 current ratio, 81
- L3L1 voltage, 81
- last start, 81
- motor status, 80
- motor temperature, 80
- operating time, 80
- power consumption, 81
- power factor, 81
- reactive power, 81
- remaining thermal capacity, 80
- starts per hour, 80
- temperature °C or °F, 80
- thermal capacity level, 80
- time, 80
- time to trip, 80
- voltage phase imbalance, 81

E

- external ground current
 - fault threshold, 75
 - fault timeout, 75
 - warning threshold, 75

F

- fault reset mode, 72
- first power-up, 48
- FLC settings, 51
- FLCmax, 51
- FLCmin, 51
- full load current settings, 51

G

- ground current
 - disable while motor starting, 75
 - fault enable, 75
 - mode, 71
 - warning enable, 75

ground current transformer
primary, 71
secondary, 71

H

HMI display
brightness setting, 80
contrast setting, 80
language setting, 80
HMI motor status LED color, 80
HMI port
address setting, 73
baud rate setting, 73
endian setting, 73
fallback action setting, 73
fault enable, 73
parity setting, 73
warning enable, 73

I

inputs/outputs
AC logic inputs configuration, 71
internal clock, 62
internal ground current
fault threshold, 75
fault timeout, 75
warning threshold, 75

J

jam
fault enable, 75
fault threshold, 75
fault timeout, 75
warning enable, 75
warning threshold, 75

L

load current transformer
multiple passes, 70
primary, 70
secondary, 70
load shedding
timeout, 78
local control
channel setting, 71
local/remote control
default mode, 71
key enable, 71
stop key disable, 71
transfer mode, 71
logic input
logic input 3 external ready, 71
long start
fault enable, 75
fault threshold, 75
fault timeout, 75

M

maintenance, 57
detecting problems, 58
troubleshooting, 59
motor
full load current, 70
full load current high speed, 70
full load current ratio, 70
full load current ratio high speed, 70
nominal power, 70, 70, 70
nominal voltage, 70
operating mode, 70
phases number, 70
rapid cycle lockout timeout, 71
star-delta, 70
step 1 to 2 threshold, 71
step 1 to 2 timeout, 71
transition mode, 71
transition timeout, 71
motor temperature
fault enable, 74
fault threshold Ω , 74
sensor threshold $^{\circ}\text{C}$, 74
sensor type, 74
warning enable, 74
warning threshold $^{\circ}\text{C}$, 74
warning threshold Ω , 74

O

over power factor
fault enable, 79
fault timeout, 79
warning enable, 79
warning threshold, 79
overcurrent
fault enable, 76
fault threshold, 76
fault timeout, 76
warning enable, 76
warning threshold, 76
overpower
fault enable, 79
fault threshold, 79
fault timeout, 79
warning enable, 79
warning threshold, 79
overvoltage
fault enable, 77
fault threshold, 77
fault timeout, 77
warning enable, 77
warning threshold, 77

P

parameters
configurable, 69
preventive maintenance, 61
configuration settings, 61
environment, 61
statistics, 61

R

- remote control
 - channel setting, 71
- replacement
 - expansion module, 63
 - LTMR controller, 63

S

- self test, 61, 62
 - enable, 61
- stop
 - key disable, 80

T

- terminal strip
 - terminal strip for stop disable, 71
- TeSys T
 - motor management system, 9
- thermal overload
 - fault enable, 74, 74
 - fault reset threshold, 74
 - fault timeout, 74
 - mode, 74
 - motor class, 74
 - warning enable, 74, 74
 - warning threshold, 74
- time stamp, 62

U

- under power factor
 - fault enable, 79
 - fault threshold, 79, 79
 - fault timeout, 79
 - warning enable, 79
 - warning threshold, 79
- undercurrent
 - fault enable, 76
 - fault threshold, 76
 - fault timeout, 76
 - warning enable, 76
 - warning threshold, 76
- underpower
 - fault enable, 79
 - fault threshold, 79
 - fault timeout, 79
 - warning enable, 79
 - warning threshold, 79
- undervoltage
 - fault enable, 77
 - fault threshold, 77
 - fault timeout, 77
 - warning enable, 77
 - warning threshold, 77

V

- voltage dip
 - mode, 78
 - restart threshold, 78, 78
 - restart timeout, 78, 78
 - threshold, 78, 78

- voltage phase imbalance
 - fault enable, 77
 - fault threshold, 77
 - fault timeout running, 77
 - fault timeout starting, 77
 - warning enable, 77
 - warning threshold, 77
- voltage phase loss
 - fault enable, 77
 - fault timeout, 77
 - warning enable, 77
- voltage phase reversal
 - fault enable, 77

W

- wiring
 - fault enable, 72
 - motor phase sequence, 72



DOCA0128EN-01

Schneider Electric Industries SAS

35, rue Joseph Monier
CS30323
F - 92506 Rueil Malmaison Cedex

www.schneider-electric.com

As standards, specifications and designs change from time to time, please ask for confirmation of the information given in this publication.

07/2018