

OVERVIEW

The Push-Button SwitchPod (sPODM) Series of low voltage wall stations interface with standard Sensor Switch occupancy sensors and power packs in order to implement a wide range of single and bi-level switching applications. These switch devices provide an elegant and cost effective way of deploying bi-level lighting control that meet energy and building codes without having to source special sensors or power packs.

FEATURES

- Enables Standard Occupancy Sensors to be used for Manual On Operation
- Alternative Usage as Override Switch for Auto-On Applications
- Single Gang Decorator Style w/ either 1 or 2 On/Off Switches
- Soft-Click Push-Buttons
- Programmable w/o Removing Switch Plate
- Optional Dual Manual On Operation
- Optional Multi-way Operation
- Optional 0-10 VDC Dimming Control
- Auto return to last set level - on dimmable devices, returns to last set dim level before switched off

Warranty

Five-year limited warranty. Complete warranty terms located at: www.acuitybrands.com/support/warranty/terms-and-conditions

Note: Actual performance may differ as a result of end-user environment and application. Specifications subject to change without notice



sPODM
Switchpod



ORDERING INFORMATION

sPODM		Example: sPODM 347							
Series	Dimming*	# of Switches/Default on Oper.	Multi-Way*	Color	Temperature / Humidity				
sPODM Switchpod	[blank] None D Dimming Operation	[blank] 1 Switch / Auto On SA 1 Switch/ Manual On 2P 2 Switches (Pole 1 Manual / Pole 2 Auto) 2P 2SA 2 Switches (Both Poles Manual)	[blank] None 3X Multi-Way (e.g. 3-way)	WH White IV Ivory GY Gray AL Light Almond BK Black	[blank] Standard LT Low Temp				

*Not available with 2 switch (2P) versions

TYPICAL CONFIGURATIONS

(NOTE: 18 AWG wire is recommended for all wiring)

BI-LEVEL (MANUAL ON / AUTO ON) SOLUTION w/ OCCUPANCY SENSOR: 1 GANG

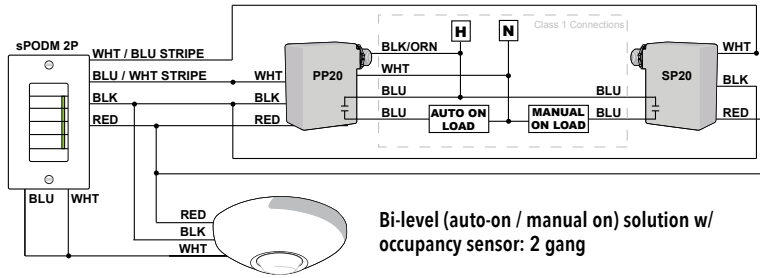

Bi-level (auto-on / manual on) solution w/ occupancy sensor: 2 gang

MANUAL ON w/ DIMMING & OCCUPANCY SENSOR

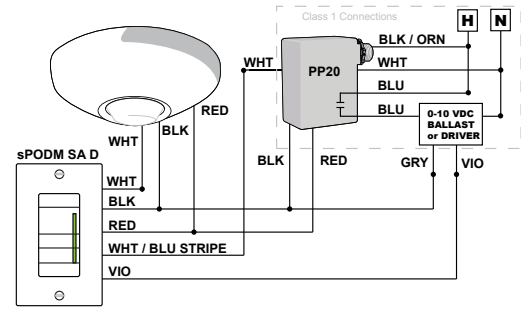

Note: If sensor also has dimming output (e.g., CM 9 ADC), connect sensor VIO wire to SPODM and ballast/driver VIO wire. Lowest output level always takes precedence. If no sensor is used, connect the SPODM white wire to the red wires.

3-WAY MANUAL ON SOLUTION w/ OCCUPANCY SENSOR

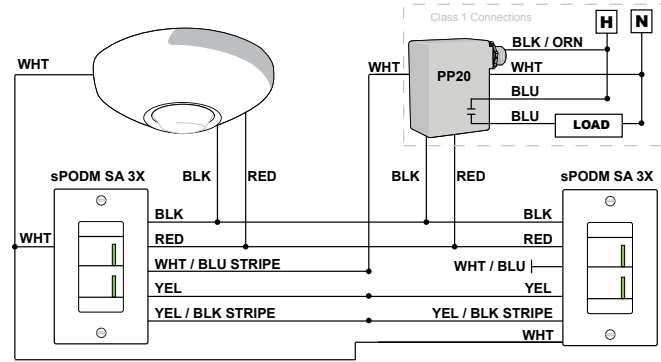
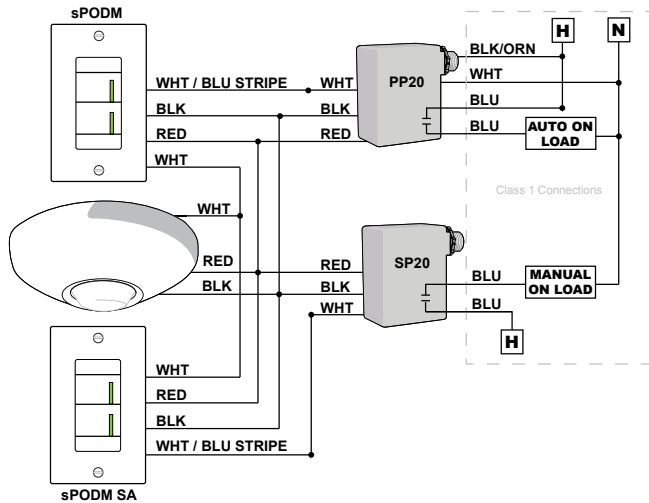

Note 1: SPODM (SA) 3X D units should only be used in multi-way applications with SPODM (SA) 3X units (non-dimming) as dimming levels are not communicated between devices.

Note 2: For multi-way configurations greater than two units, connect additional unit(s) in same manner as bottom right SPODM SA 3X unit in diagram above.

Note 3: If no sensor is used, connect the SPODM white wire to the red wires.

PROGRAMMING INSTRUCTIONS *(Please read all 7 steps before programming)*

1. Enter programming mode by pressing & holding upper most button until LED flashes rapidly. Release button.
2. Enter the *On Mode* function by pressing button twice.
3. The current *On Mode* setting will then be fed out in a sequence of LED flashes as indicated in the table below (e.g., one flash for Auto-On). To change the setting, proceed to step 4 before sequence repeats 10 times.
4. At any time while the switch is flashing back the current *On Mode* setting, interrupt it by pressing button the number of times for the new desired *On Mode* setting as indicated in the table below (e.g., press twice for Manual On). Switch will begin to flash back new setting as confirmation.
5. Next, while the switch is flashing back new setting, interrupt it by pressing and holding button until LED flashes rapidly. Release button.
6. As final confirmation and activation of the new setting, press button two times.
7. LED will flash twice indicating acceptance of new setting. If two flashes are not seen, repeat 7 step process.

Note: To exit programming mode without saving, wait for blink back sequence to repeat 10 times then return to step 1.

Function Number	Function Name	Settings (see ordering block for defaults)		
		Setting Number	Pole 1	Pole 2 (2P devices only)
2	On Mode	1	Auto-On	Manual On
		2	Manual On	Auto-On
		3 (2P devices only)	Manual On	Manual On
		4 (2P devices only)	Auto-On	Auto-On

SPECIFICATIONS

Electrical

Input Ratings 12-24VAC/VDC, 5mA

Output Ratings Sinks <20mA

Mechanical

Dimensions 2.74"H x 1.68"W x 1.63"D (70mm x 43mm x 41mm) - does not include ground strap

Mounting Single-Gang Box or Low Voltage Ring

Connection Type Low Voltage Leads

Environmental

Warrantied Operating Temperature -22°F to 185°F (-30°C to 85°C)

Relative Humidity Up to 90%, Non-Condensing

Standards/ Ratings RoHS

General

Standards/ Ratings CEC Title 20