



Compact 5 Watt LED floodlight perfectly suited for small-scale landscape lighting applications. 85% more energy efficient than its 35 Watt MR16 equivalent. Specialized microprismatic lens delivers even and consistent light. Utilizes line voltage (120V-240V).

Color: Black

Weight: 1.5 lbs

Project:

Type:

Prepared By:

Date:

### Driver Info

Type	Constant Current
120V	0.1A
208V	0.06A
240V	0.05A
277V	N/A
Input Watts	5.1W

### LED Info

Watts	5W
Color Temp	3000K (Warm)
Color Accuracy	86 CRI
L70 Lifespan	100,000 Hours
Lumens	208
Efficacy	40.8 lm/W

## Technical Specifications

### Compliance

#### UL Listed:

Suitable for wet locations. Suitable for ground mounting.

#### IESNA LM-79 & IESNA LM-80 Testing:

RAB LED luminaires and LED components have been tested by an independent laboratory in accordance with IESNA LM-79 and LM-80.

### Performance

#### Lifespan:

100,000-Hour LED lifespan based on IES LM-80 results and TM-21 calculations

### Optical

#### Spot Lens:

Optional spot lens enables a tool-less conversion to a NEMA Type 3H x 3V. Great for accent lighting or grazing buildings for an artistic touch. [Spot reflector kit available here.](#)

#### NEMA Type:

NEMA Beam Spread of 4H x 4V

### LED Characteristics

#### LED:

5 Watt high output, long-life LED

#### Color Consistency:

3-step MacAdam Ellipse binning to achieve consistent fixture-to-fixture color

#### Color Stability:

LED color temperature is warranted to shift no more than 200K in color temperature over a 5-year period

#### Color Temperature:

3000K

#### Color Uniformity:

RAB's range of Correlated Color Temperature follows the guidelines of the American National Standard for (SSL) Products, ANSI C78.377-2017.

### Construction

#### Lens:

Microprismatic diffusion lens for smooth and even light distribution

#### Cold Weather Starting:

Minimum starting temperature is -40°C (-40°F)

#### Maximum Ambient Temperature:

Suitable for use in up to 40°C (104°F)

#### Housing:

Precision die-cast aluminum housing, hood and mounting arm

**Technical Specifications (continued)**

**Construction**

**Gaskets:**

High-temperature Silicone

**Finish:**

Formulated for high durability and long-lasting color

**Green Technology:**

Mercury and UV free. RoHS-compliant components.

**Other**

**Warranty:**

RAB warrants that our LED products will be free from defects in materials and workmanship for a period of five (5) years from the date of delivery to the end user, including coverage of light output, color stability, driver performance and fixture finish. RAB's warranty is subject to all terms and conditions found at [rablighting.com/warranty](http://rablighting.com/warranty).

**Patents:**

The design of the LFLED is protected by Taiwan Patent 01510966 and pending patents in US, Canada, China, and Mexico

**Buy American Act Compliance:**

RAB values USA manufacturing! Upon request, RAB may be able to manufacture this product to be compliant with the Buy American Act (BAA). Please contact customer service to request a quote for the product to be made BAA compliant.

**Electrical**

**Driver:**

Constant Current, Class 2, 100-240V, 50-60Hz, 100-240VAC 0.18A.

**Dimensions**

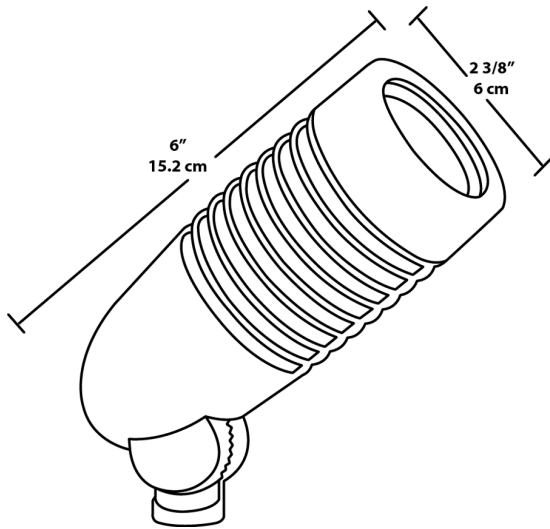

**Features**

- Microprismatic diffusion lens for even light distribution
- 4H x 4V NEMA type with 44° Beam Angle
- Optional spot hood reflector available
- 100,000-hour life based on LM-80 results and TM-21 calculations
- 5-Year, No-Compromise Warranty

**Ordering Matrix**

Family	Wattage	Color Temp	Finish
LFLED	5	Y	B
	5 = 5W	Blank = 5000K Cool Y = 3000K Warm N = 4000K Neutral	A = Bronze W = White B = Black VG = Verde Green