

THIS COPY IS PROVIDED ON A RESTRICTED BASIS AND IS NOT TO BE USED IN ANY WAY DETRIMENTAL TO THE INTERESTS OF PANDUIT CORP.

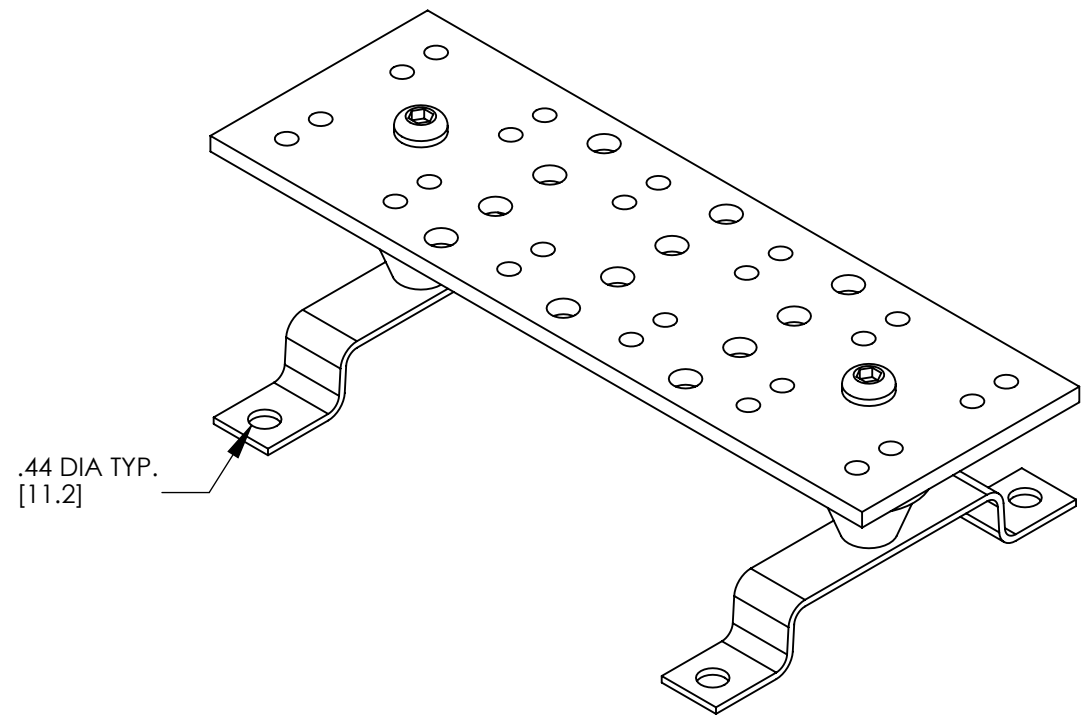
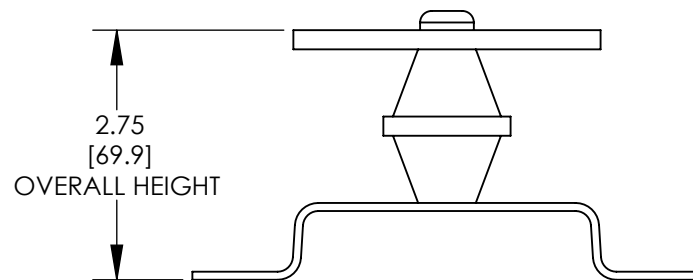
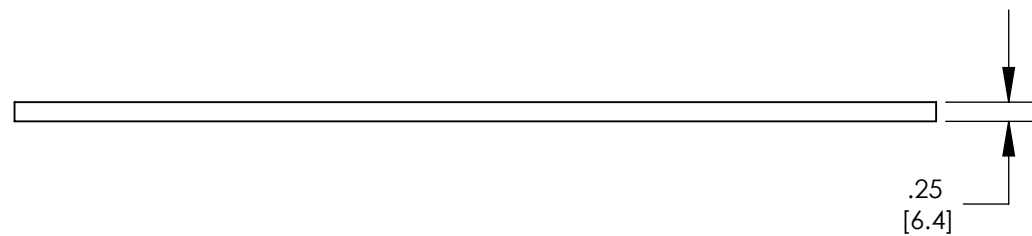
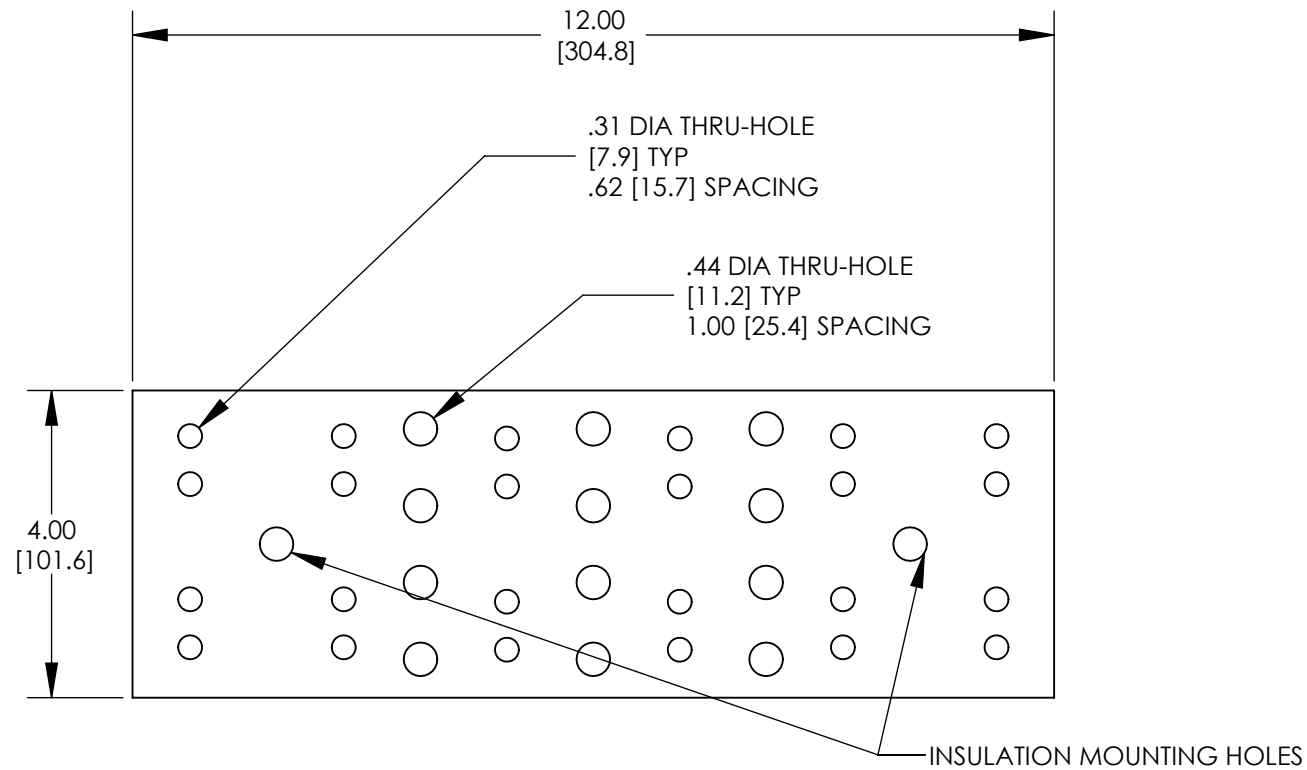

ASSEMBLED AS SHOWN

NOTES:

1. KIT COMES FULLY ASSEMBLED
2. KIT INCLUDES BUSBAR, MOUNTING BRACKETS, INSULATORS, AND MOUNTING HARDWARE.
3. MEETS BICSI/ANSI/TIA-607-D
4. DIMENSIONS IN PARENTHESIS ARE MILLIMETERS.



							TITLE	GROUNDING BUSBAR (GB4B0612TPI) CUSTOMER DRAWING		
							ITEM REVISION NAME	N41502BA/07		
							DATASET FILE NAME	C41502 r07.SLDDRW		
							UNLESS OTHERWISE SPECIFIED, DIMENSIONAL TOLERANCES ARE: IN [mm]			
							.X ±			
							.XX ±	ANGLES ±		
								THIRD ANGLE PROJECTION		MATERIAL
										SEE NOTES
										DRAWING NUMBER
										C41502
REV	DATE	BY	CHK	APR	DESCRIPTION	ECN	DRAWN BY	DATE	CHK	SCALE
							JHNU	2/05		NONE
										SHEET 1 OF 1
										SIZE
										B

07	3/22	JHNU	JHNU	ALP	REVISED NOTE 3: MEETS BICSI/ANSI/TIA-607-D WAS MEETS BICSI/J-STD-607-A	119913
06	3/13	JHNU	JHNU	RGB	REVISED TITLE BLOCK	N41502BA-C41502