

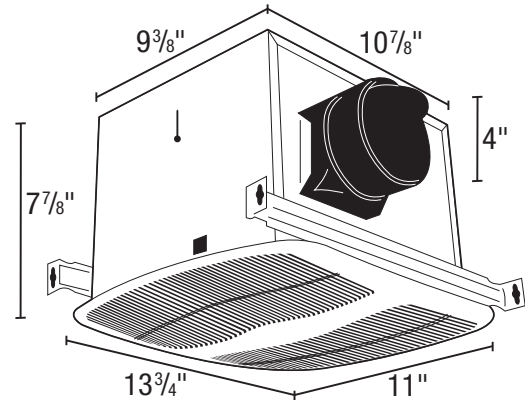

SPECIFICATIONS  
**AK80LS-1**  
 EXHAUST FAN

**HVI**  
 2100  
 CERTIFIED  
**80 CFM/1.0 Sones @ 0.10" SP.**  
**68 CFM @ 0.25 SP.**



- **Grill**  
 White, polymeric grill secured in place with torsion springs; easily removed if necessary, dimensions - 11" x 13 3/4".
- **Blower Wheel**  
 One piece polymeric centrifugal blower wheel, 5 7/32" diameter, 2 29/32" wide, with 30 paddles.
- **Motor**  
 Heavy duty, permanently split capacitor, plug-in, 4 pole motor, life time lubrication, suitable for continuous operation. Rated 120 volts, 60 hz.
- **Fan Housing**  
 23 gauge galvanized steel housing.  
 Dimensions: 10 7/8" x 9 7/8" x 7 7/8".
- **Duct Collar**  
 Plastic collar for 4" duct connection, comes complete with built in non-metallic back draft damper for quiet operation.
- **Ventilating Area**  
 For bathrooms up to 80 sq. ft. For other rooms up to 100 sq. ft.
- **Electrical Connections**  
 1/2" electrical knockouts provided.
- **Single Pack Shipping Info**  
 Box Dim Box Dim: 16" x 14 3/8" x 9 7/8"  
 UPC: 0-8316228002-2  
 Shipping Weight: 12 lbs.

Acceptable for use over tub or shower when installed in a GFCI protected branch circuit.



- **Unit Mounting**  
 The housing will mount in ceilings with at least 8" of clearance and through drywall thickness up to 3/4", with a rough-in opening of 11" x 9 1/2". The housing will mount either between 16" or 24" on center joists, using the 4 supplied housing mounting rails. The housing mounting rails can be adapted for overhead mounting (hardware not provided).

EXPANDED PERFORMANCE											
	Static Pressure (inches of w.g.)							Sones @ .1 SP	Fan Speed RPM	Maximum Fan Watts	Amps
	0	0.05	0.1	0.125	0.15	0.2	0.25				
<b>Air Flow - CFM</b>	87	83	80	78	77	72	68	1.0	975	28.1	0.3

<b>PROJECT</b>							<b>ARCHITECT</b>				
<b>LOCATION</b>							<b>ENGINEER</b>				
<b>CONTRACTOR</b>							<b>SUBMITTED BY</b>			<b>DATE</b>	
FAN NUMBER	MODEL NUMBER	CFM	IN W.G.	RPM	WATTS	AMPS	SONES	QTY	OPTIONAL EQUIPMENT & REMARKS		



**U.S.:** 820 Lincoln Avenue  
 West Chester, Pennsylvania 19380-4466  
 Tel: (610) 692-7400 • 877-304-3785  
 Fax: (610) 696-8048

**Canada:**  
 Bolton, Ontario  
 Tel: 905-456-2033