

# INSTRUCTIONS

## FIELD-ADJUSTABLE TOMO™ INSTALLATION

# RAB®

RAB Lighting is committed to creating high-quality, affordable, well-designed and energy-efficient LED lighting and controls that make it easy for electricians to install and end users to save energy. We'd love to hear your comments. Please call the Marketing Department at 888-RAB-1000 or email: [marketing@rablighting.com](mailto:marketing@rablighting.com)

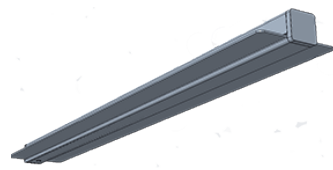

TOMO- 2FT

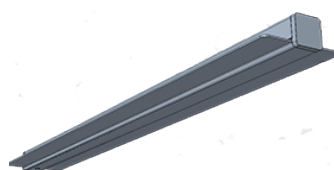

TOMO- 4FT

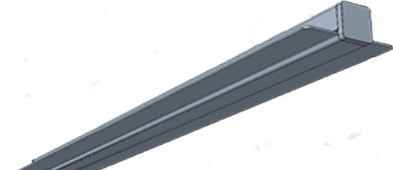

TOMO- 8FT

### IMPORTANT

#### READ CAREFULLY BEFORE INSTALLING FIXTURE. RETAIN THESE INSTRUCTIONS FOR FUTURE REFERENCE.

RAB fixtures must be wired in accordance with the National Electrical Code and all applicable local codes. Proper grounding is required for safety. THIS PRODUCT MUST BE INSTALLED IN ACCORDANCE WITH THE APPLICABLE INSTALLATION CODE BY A PERSON FAMILIAR WITH THE CONSTRUCTION AND OPERATION OF THE PRODUCT AND THE HAZARDS INVOLVED.

**WARNING: Make certain power is OFF before installing or maintaining fixture. No user serviceable parts inside.**  
The fixture is suitable for indoor applications. Suitable for damp locations. Ceiling, Canopy and Pendant mount only.

### SURFACE MOUNTING

1. Secure **Surface Mounting Plate** to Junction Box (*by others*). (Additional attachment to the ceiling may be needed for longer fixtures). 8ft TOMO includes a 2nd **Surface Mounting Plate** and **Surface Mount Adapter Plate** (see Fig. 2).
2. Remove **Silicone Plugs** located on each end of the **Housing Cover** as shown in Fig. 2 (*do not discard Silicone Plugs*).
3. Pull the **End Caps** out of each end of the fixture as shown in Fig. 1. Separate the **Housing Cover** from the **Lens and Tray Assembly** by sliding the **Housing Cover** either right or left to unlock from **Key Slots** as shown in Fig. 3. Pre-installed **Tether Cables** (2) will prevent **Lens and Tray Assembly** from separating from **Housing Cover** (Fig. 1).
4. Pull supply wires from Junction Box (*by others*) through center of **Surface Mounting Plate**. Use appropriate UL rated wire connectors as required by NEC and local code to make electrical splices to fixture leads.
5. Align **Surface Mount Adapter Plate** to the **Housing Cover**. Using (4) **Screws** (*provided*) secure **Surface Mount Adapter Plate** and **Housing Cover** to the **Surface Mounting Plate**.
6. Follow appropriate wiring instructions per code (Fig. 13).
7. Push **Lens and Tray Assembly** into the **Housing Cover**. Align **Keys** into **Key Slots** and slide to the right or left to lock the **Housing Cover** into the **Lens and Tray Assembly**. Snap on **End Caps** and insert **Silicone Plugs** into **Housing Cover**.

**WARNING: To prevent wiring damage or abrasion, do not expose wiring to edges of sharp objects.**

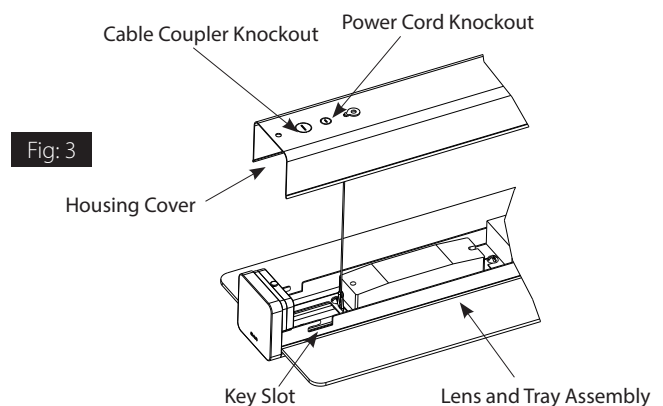
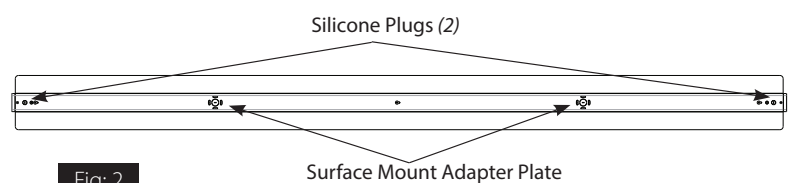
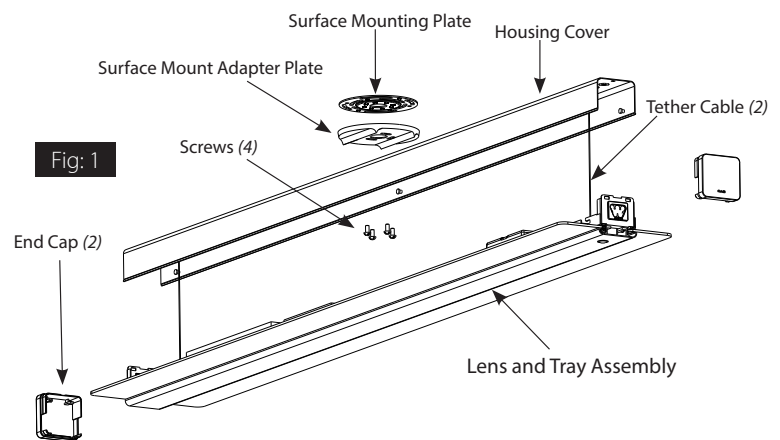

# INSTRUCTIONS

## FIELD-ADJUSTABLE TOMO™ INSTALLATION



RAB Lighting is committed to creating high-quality, affordable, well-designed and energy-efficient LED lighting and controls that make it easy for electricians to install and end users to save energy. We'd love to hear your comments. Please call the Marketing Department at 888-RAB-1000 or email: [marketing@rablighting.com](mailto:marketing@rablighting.com)

### CANOPY KIT-TO-FIXTURE INSTALLATION

1. Remove **End Caps**. Slide **Lens Tray Assembly** from **Housing Cover** to release **Tray Assembly** by sliding the fixture to the right to unlock from **Key Slots** as shown in Fig. 3. Pre-installed **Tether Cables (2)** will prevent **Lens and Tray Assembly** from separating from **Housing Cover** as shown in Fig. 1.
2. For **Canopy Mounting**, remove (2) **Knockouts** on the **Housing Cover** as shown in Fig. 4.
3. Insert **Cable Couplers** from the inside of the **Housing Cover** through the two respective Cable Coupler **Knockouts** as shown in Fig. 5.
4. Secure the **Cable Couplers** with **Cable Coupler Nuts** onto the **Housing Cover** as shown in Fig. 5.
5. Insert the **Cable** into the **Cable Couplers**. Adjust the length of the **Cable** and tighten the **Locknuts** and trim any excess cable inside the fixture.
6. Pull supply wires through **Power Cord Knockout** and make connection inside the fixture. Pass the **Power Cord** and Cable through the **Canopy Rings**. Adjust the length of the **Power Cord** and tighten it on the **Canopy** with **Strain Reliefs (Fig. 6)**.
8. Mount all **Canopies** to the Fixture with appropriate **Cable** length.
9. Follow appropriate wiring instructions per NEC and local code (Fig. 13).

Fig: 4

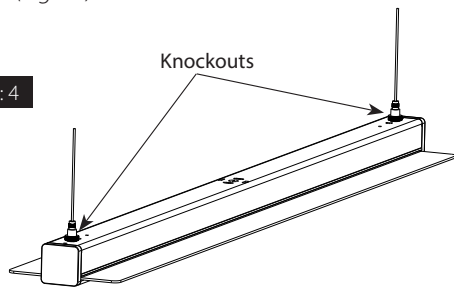
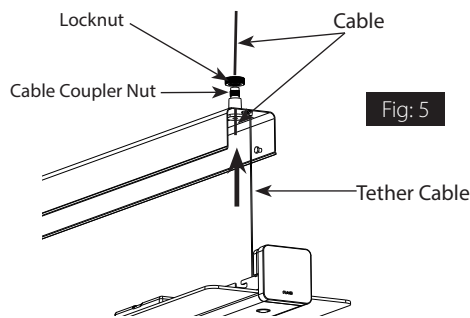

Fig: 5



### CANOPY-TO-SURFACE MOUNTING

1. Slide **Power Cord** through the hole on **Canopy** and tighten with **Strain Relief**.
2. Connect wires per NEC and local code as shown in wiring diagram (Fig. 13). Push all wires back into the **Junction Box**. Be careful not to pinch wires. Mount the **Cross Bar** on Junction Box.
3. Mount the **Canopy** to the Junction Box. Push **Cable Coupler** on the **1/4-20 Stud** and tighten the **Coupler**.
4. **Canopy** and **Cable** without **Power Cord** can be mounted with a **1/4-20 Stud** and hardware appropriate to mounting surface.
5. Push **Lens and Tray Assembly** into the **Housing Cover**. Align **Keys** into **Key Slots** and slide to the left to lock the **Housing Cover** into the **Lens and Tray Assembly**. Snap on **End Caps**.

**WARNING:** To prevent wiring damage or abrasion, do not expose wiring to edges of sharp objects.

Fig: 6

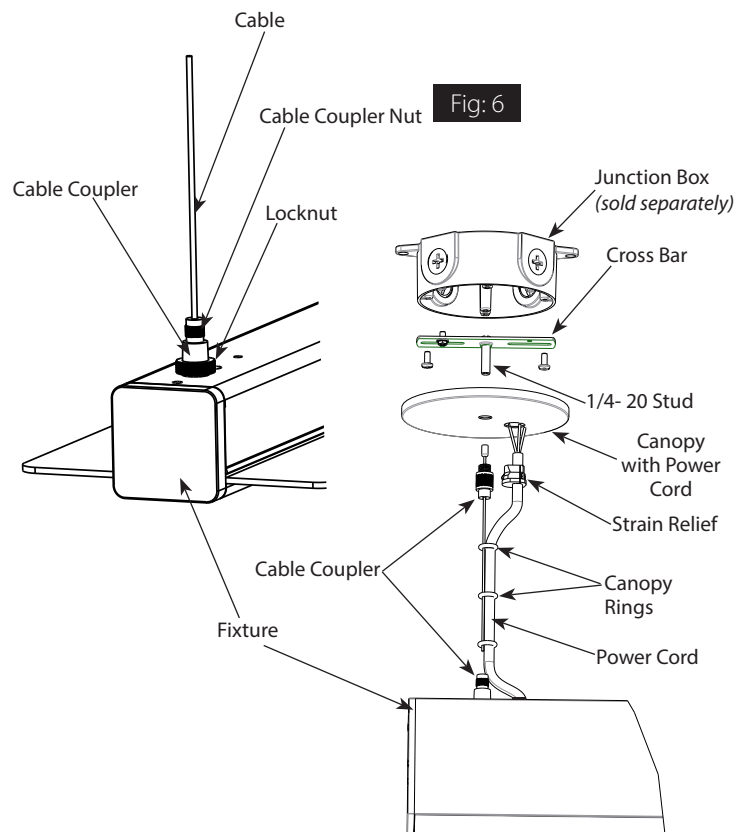

# INSTRUCTIONS

## FIELD-ADJUSTABLE TOMO™ INSTALLATION



RAB Lighting is committed to creating high-quality, affordable, well-designed and energy-efficient LED lighting and controls that make it easy for electricians to install and end users to save energy. We'd love to hear your comments. Please call the Marketing Department at 888-RAB-1000 or email: [marketing@rablighting.com](mailto:marketing@rablighting.com)

### CONTINUOUS RUN MOUNTING (PENDANT)

Multiple fixtures can be mounted together using TOMO CONNECT (sold separately).

**Note:** Continuous Run Mounting is not available with LIGHTCLOUD® /LC, /LC/E, /LCB suffix.

1. For continuous run, remove fixture **End Caps** (Fig. 7). Pop out **Silicone Plugs**, push Fixtures together using **TOMO CONNECT** (ordered separately) between fixtures for quick connect installation (Fig. 8). **TOMO CONNECT** is provided with (2) **Fixing Screws**. Install **Fixing Screws** in **Silicone Plug** points. Only (1) one **Fixture** needs to be electrically hard wired from above (Fig. 9).
2. **CAUTION:** The maximum number of fixtures allowed to be linked together is indicated in table below (120V through 277V only).

**WARNING:** To prevent wiring damage or abrasion, do not expose wiring to sharp objects.

Catalog #	Maximum Number of Linked Fixtures
TOMO-2	Up to 28 fixtures
TOMO-4	Up to 14 fixtures
TOMO-8	Up to 7 fixtures

### FIELD ADJUSTMENT

Follow instructions below to change the fixture **Color Temperature (CCT)** and **Power (W)** from the factory settings.

Factory Settings: TOMO-2 18W / 4000K  
 TOMO-4 36W / 4000K  
 TOMO-8 72W / 4000K

1. Remove **End Caps**. Slide **Lens Tray Assembly** from **Housing Cover** to release **Tray Assembly** from **Housing Cover** by sliding the fixture to the right to unlock from **Key Slots** as shown in Fig. 3. Pre-installed **Tether Cables** (2) will prevent **Lens and Tray Assembly** from separating from **Housing Cover** as shown in Fig. 1.
2. Locate the selector switches inside the **Lens & Tray Assembly** as shown (Fig. 10, 11, 12) for TOMO-2, TOMO-4 TOMO-8. **Note:** TOMO-8 is equipped with two (2) **Color Temperature (CCT)** switches and two (2) **Power (W)** switches.
3. Select **Color Temperature (CCT)** and/or **Power (W)** by sliding the respective switch to the desired value.
4. After the switch is positioned to the desired setting, push **Lens and Tray Assembly** into the **Housing Cover**. Align **Keys** into **Key Slots** and slide to the left to lock the **Housing Cover** into the **Lens and Tray Assembly**. Snap on **End Caps**.

**WARNING:** To prevent wiring damage or abrasion, do not expose wiring to edges of sharp objects.

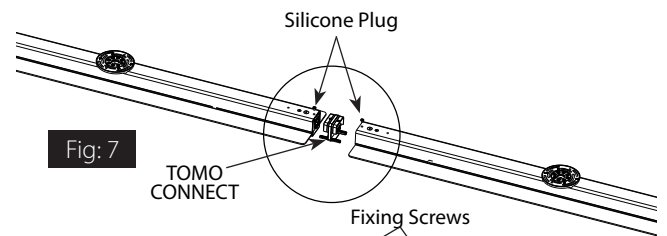

Fig. 7

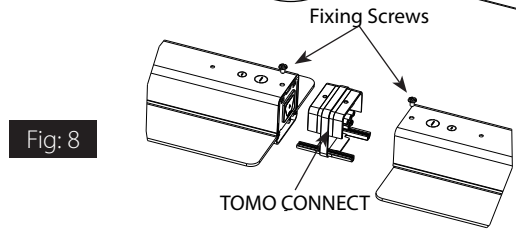

Fig. 8

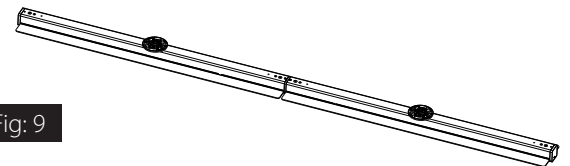

Fig. 9

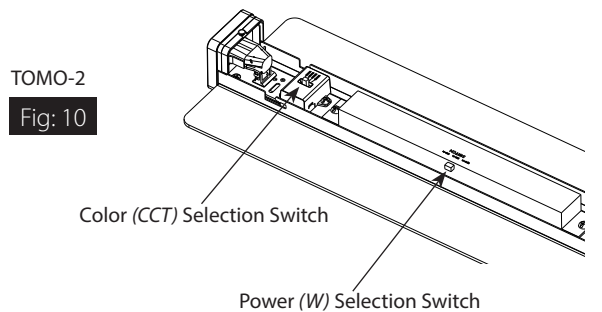

Fig. 10

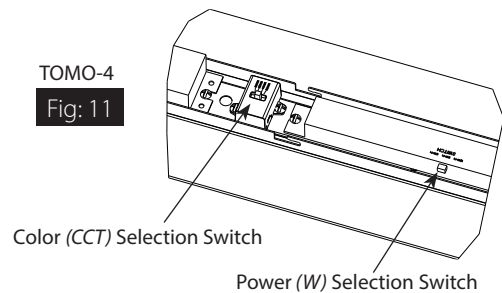

Fig. 11

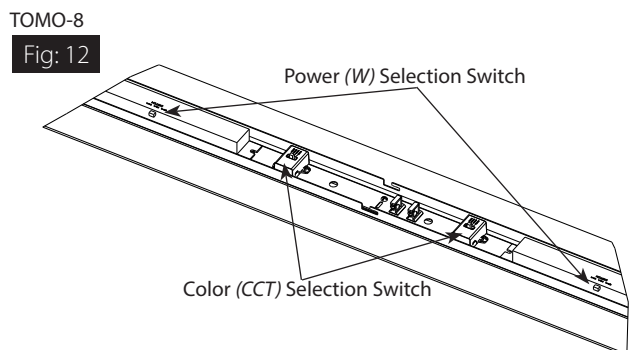

Fig. 12

# INSTRUCTIONS

## FIELD-ADJUSTABLE TOMO™ INSTALLATION



RAB Lighting is committed to creating high-quality, affordable, well-designed and energy-efficient LED lighting and controls that make it easy for electricians to install and end users to save energy. We'd love to hear your comments. Please call the Marketing Department at 888-RAB-1000 or email: [marketing@rablighting.com](mailto:marketing@rablighting.com)

### PIR MODELS (INTERNAL)

See factory settings below (optional remote sold separately for custom settings, CAT# TOMO-REMOTE).

#### Factory Settings:

- Hold Time: 1 Minute
- Stand-by period: 1 Minute
- Stand-by dimming level: 10%
- Constant Lux: 50Lux
- Detection range: Disabled

### DETECTION PATTERN

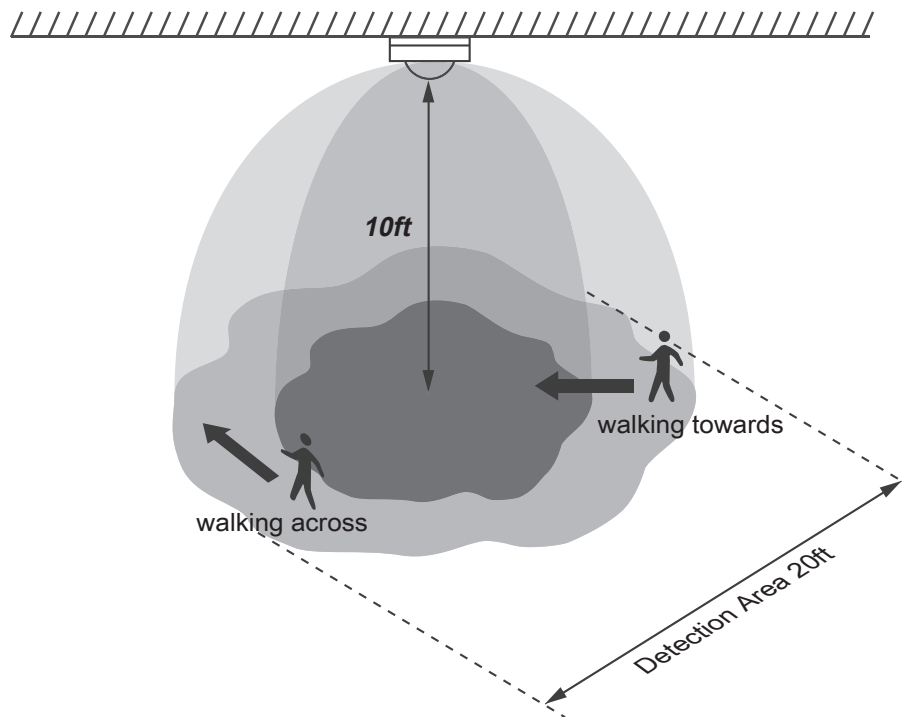

# INSTRUCTIONS

## FIELD-ADJUSTABLE TOMO™ INSTALLATION



RAB Lighting is committed to creating high-quality, affordable, well-designed and energy-efficient LED lighting and controls that make it easy for electricians to install and end users to save energy. We'd love to hear your comments. Please call the Marketing Department at 888-RAB-1000 or email: [marketing@rablighting.com](mailto:marketing@rablighting.com)

### 0-10V DIMMABLE WIRING

Universal voltage driver permits operation at 120V through 277V, 50 or 60 Hz. For 0-10V dimming, follow the wiring directions as shown in Fig. 13.

1. Connect the black fixture lead to the LINE supply lead.
2. Connect the white fixture lead to the COMMON supply lead.
3. Connect the GROUND wire from fixture to supply ground.
4. Connect the purple fixture lead to the (V+) DIM lead.
5. Connect the pink fixture lead to the (V-) DIM lead.
6. Cap the yellow fixture lead, if present. Do NOT connect.

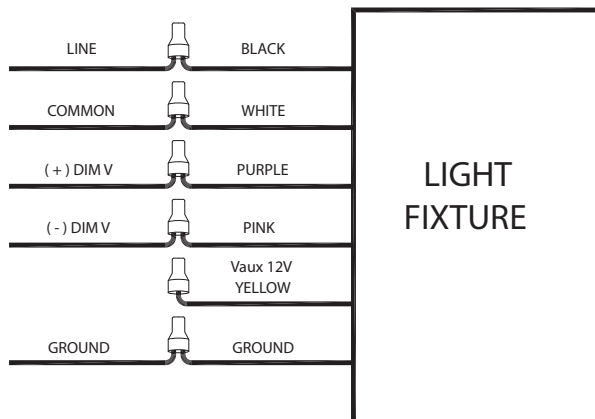

Fig. 13

### CLEANING & MAINTENANCE

**CAUTION:** Be sure fixture temperature is cool enough to touch. Do not clean or maintain while fixture is energized.

1. Clean acrylic lens with non-abrasive cleaning solution.
2. Do not open the fixture to clean the LEDs. Do not touch the LEDs.

### TROUBLESHOOTING

1. Check that the line voltage at the fixture is correct. Refer to wiring directions.
2. Is the fixture grounded properly?

**Note:** These instructions do not cover all details or variations in equipment nor do they provide for every possible situation during installation, operation or maintenance.

# INSTRUCTIONS

## FIELD-ADJUSTABLE TOMO™ INSTALLATION



RAB Lighting is committed to creating high-quality, affordable, well-designed and energy-efficient LED lighting and controls that make it easy for electricians to install and end users to save energy. We'd love to hear your comments. Please call the Marketing Department at 888-RAB-1000 or email: [marketing@rablighting.com](mailto:marketing@rablighting.com)

# BATTERY BACKUP MODELS

## WIRING

### CAUTION: FOR BATTERY BACKUP FIXTURE (TOMO-4/TOMO-8)

Voltage could be present in **BATTERY**. To prevent high voltage from being present on output leads, Inverter Connector must be open. Do not join **BATTERY** connector until installation is complete and AC power is supplied to the emergency driver (Fig. 14).

**NOTE:** Make sure that the necessary branch circuit wiring is available. An **UNSWITCHED AC** source of power is required. The emergency driver must be fed from the same branch circuit as the LED driver.

**CAUTION:** Do not use any supply voltage other than 120-277V 50/60 HZ.

1. Connect **UNSWITCHED HOT** fixture lead to **HOT AC** supply line.
2. If using an **UNSWITCHED** circuit, connect **UNSWITCHED** and **SWITCHED** lines together.
3. If using a **SWITCHED** circuit, connect **SWITCHED HOT AC fixture** lead to the external control.
4. For 0-10V dimming, connect **DIM (+)** purple lead and **DIM (-)** pink lead to 0-10V dimmer connections.
5. Connect **GROUND** lead from the fixture to the supply ground. Do not connect **GROUND** to the output leads.
6. All unused leads must be capped and insulated.
7. After installation is complete, supply AC power to the fixture and connect the **BATTERY** (Fig. 14).
8. When power is on, the fixture should be on and the **Charging Indicator Light** should illuminate to indicate the battery is charging.
9. Once the **BATTERY** has charged for at least one hour, a short duration test may be performed by pressing the test button (Fig. 15).
10. After the battery has charged for 24 hours, a long duration test can be performed by shutting power to the fixture.

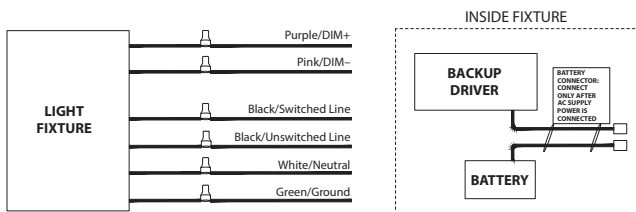

Fig: 14

## OPERATION

1. When AC power is applied, the charging indicator light is illuminated indicating that the **BATTERY** is being charged.
2. When power fails, the standby power automatically switches to backup mode at reduced power resulting in lower illumination. The emergency driver supplies power in standby mode for a minimum of 90 minutes.
3. When AC power is restored, the emergency driver automatically returns to charging mode.

## MAINTENANCE

Although no routine maintenance is required to keep the emergency driver functional, it should be checked periodically to ensure that it is working. The following schedule is recommended:

1. Visually inspect the charging indicator light monthly. It should be illuminated.
2. Test the emergency operation of the fixture at 30-day intervals for a minimum of 30 seconds.
3. Conduct a 90-minute discharge test once a year. Fixture would operate at reduced illumination for a minimum of 90 minutes.

## TROUBLESHOOTING

1. Is the fixture grounded properly?
2. If the charging indicator light does not illuminate after pressing the **Test Button** (Fig. 15), check if battery is connected properly.

**Note:** These instructions do not cover all details or variations in equipment nor do they provide for every possible situation during installation, operation or maintenance.

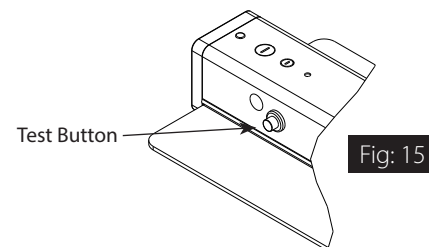

Fig: 15



© 2024 RAB LIGHTING Inc.  
TOMO - IN - 0124  
P-100173

### Easy Answers

[rablighting.com](http://rablighting.com)  
Visit our website for product info

**Tech Help Line**  
Call our experts: 888 722-1000

**e-mail**  
Answered promptly - [sales@rablighting.com](mailto:sales@rablighting.com)

**Free Lighting Layouts**  
Answered online or by request

**RAB WARRANTY:** RAB's warranty is subject to all terms and conditions found at [rablighting.com/warranty](http://rablighting.com/warranty).