

CH361AWKEI

Safety switch, heavy duty, fusible, 30A, 600 VAC/VDC, 3 poles, 20 hp, NEMA 12, interlock



Main

Range	Square D
Product	Single Throw Safety Switch
Current Rating	30 A
Enclosure Rating	NEMA 3R/12 galvanized steel
Horsepower Rating	5 Hp 480 V at AC 50-60 Hz for 3 phase conforming to NEC 240.6 15 Hp 480 V at AC 50-60 Hz for 3 phase conforming to NEC 430.52 7.5 Hp 600 V at AC 50-60 Hz for 3 phase conforming to NEC 240.6 20 Hp 600 V at AC 50-60 Hz for 3 phase conforming to NEC 430.52 5 Hp 250 V at DC 15 hp 600 V at DC
Disconnect Type	Fusible disconnect
Short Circuit Current Rating	10 KA 200 kA
Mounting Type	Surface
Number of Poles	3
Phase	3 phase
Certifications	CSA
Voltage Rating	600 V AC/DC
Wire Configuration	4-wire
Wire Size	AWG 12...AWG 2 aluminium AWG 14...AWG 2 copper

Complementary

Tightening torque	45 Lbf.In (5.08 N.m) 0.02 in ² (13.3 mm ²) (AWG 6) 40 Lbf.In (4.52 N.m) 0.01 in ² (8.367 mm ²) (AWG 8) 35 lbf.in (3.95 N.m) 0.00...0.01 in ² (2.06...5.21 mm ²) (AWG 14...AWG 10)
Width	7.55 in (191.77 mm)
Height	14.6 in (370.84 mm)
Depth	4.96 in (125.98 mm)

Ordering and shipping details

Category	00153-C,CH&CHU CANADA SW NON-NEG
Discount Schedule	DE 1
GTIN	785901594550
Nbr. of units in pkg.	1
Package weight(Lbs)	12.00 lb(US) (5.443 kg)
Returnability	Yes
Country of origin	US

Packing Units

Unit Type of Package 1	PCE
Package 1 Height	31.44 in (79.849 cm)
Package 1 width	7.37 in (18.732 cm)
Package 1 Length	13.44 in (34.129 cm)



Offer Sustainability

Sustainable offer status	Green Premium product
California proposition 65	WARNING: This product can expose you to chemicals including: Lead and lead compounds, which is known to the State of California to cause cancer and birth defects or other reproductive harm. For more information go to www.P65Warnings.ca.gov
REACH Regulation	REACH Declaration
REACH free of SVHC	Yes
EU RoHS Directive	Compliant EU RoHS Declaration
Mercury free	Yes
RoHS exemption information	Yes
China RoHS Regulation	China RoHS Declaration
Environmental Disclosure	Product Environmental Profile
PVC free	Yes

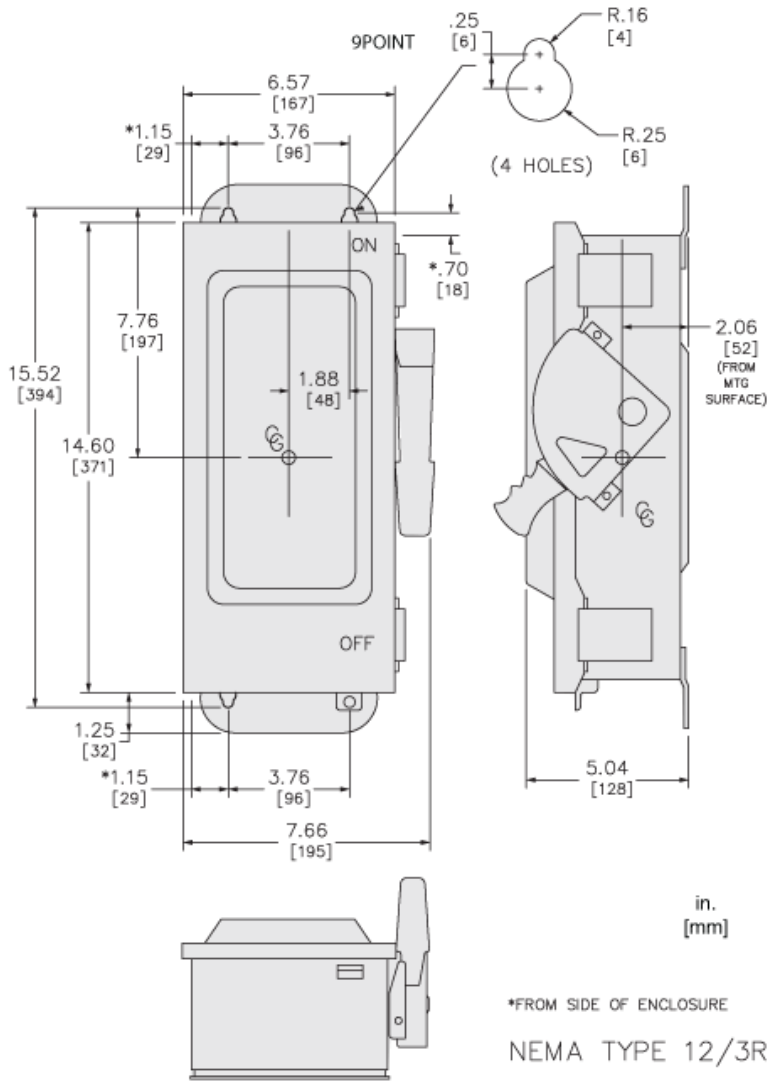
Approximate Dimensions

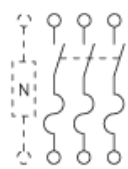

Connections and Wiring Diagrams

WIRING DIAGRAMS		
FUSIBLE	NOT FUSIBLE	
 H221AWK	 H321AWK H361AWK	 HU361AWK HU361AWKEI