

Project		Catalog #		Type	
Prepared by		Notes		Date	

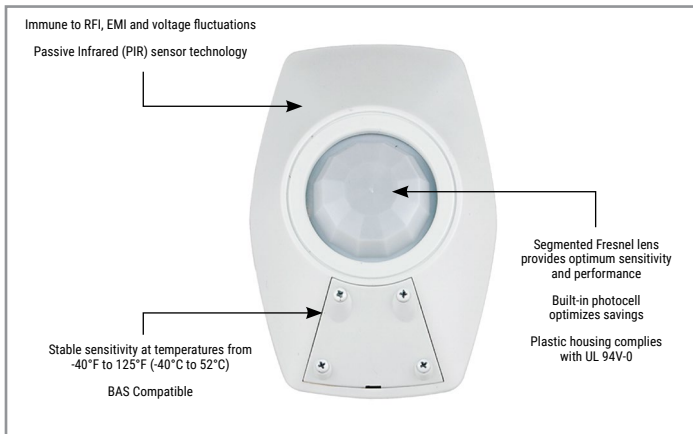

Greengate

OXC-P Extreme Temperature PIR Ceiling Sensor

Provides consistent, stable coverage where extreme heat, cold or humidity must be accommodated and where there are wide fluctuations in temperature

Typical Applications

Parking Structures • Warehouses (OXC-P-2MH0-R)
High Ceilings • Walk-in Freezers (OXC-P-1500-R) • Cold Storage

Interactive Menu

- Order Information [page 2](#)
- Wiring Diagrams [page 3](#)
- Additional Resources [page 4](#)
- Product Warranty

Product Certification



Product Features



Top Product Features

- The Passive Infrared Extreme Temperature sensor provides consistent, stable coverage where extreme heat, cold or humidity must be accommodated and where there are wide fluctuations in temperature.
- Temperature compensating circuitry stabilizes sensitivity at temperatures -40°F to 125°F (-40°C to 52°C).
- UL Listed for damp locations
- OXC-P-2MH0-R works at heights up to 25 ft.
- Ambient light control circuit to avoid false-on/off from brief changes in background light
- Temperature-compensating circuitry avoids false activation in extreme conditions
- Products tested to NEMA WD 7 - 2011 Occupancy Motion Sensors Standard

Dimensional Details

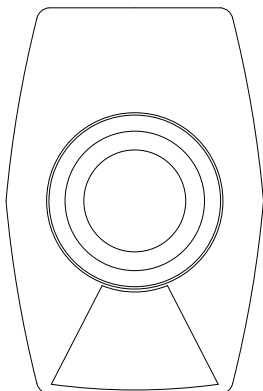

Mounting Height

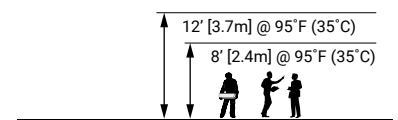

[additional product diagrams](#)

Order Information

Catalog Number

Catalog Number	Coverage	Field of View	Features
OXC-P-1500-R	Up to 1,500 sq. ft	Two Way (360°)	w/BAS Relay & Daylight Sensor
OXC-P-2MH0-R	When mounted @ 25 ft., up to 25 ft. in all directions or 50 linear ft. for warehouse aisles	Two Way (360°)	w/BAS Relay & Daylight Sensor

Product Specifications

Key Features

- Passive Infrared (PIR) technology

Note:

- Fresnel lens made of UV stabilized Poly-IR material.
- Coverage pattern tested to NEMA WD 7

Mechanical

Size: 1-5/8"H x 4-1/2"W x 3-1/8"D (41.3mm x 114.3mm x 79.4mm)

Environment:

- **Operating temperature:** -40° F to 125° F (-40° C to 52° C)
- **Relative humidity operating:** Relative humidity: less than 95%, non-condensing
- Indoor or outdoor (refer applications section)

Mounting: Box Mount, Surface Mounted

Mounting Height: 25 ft

Housing: Medium impact injection molded housing.
ABS resin complies with UL 94V-0. Paintable off-white

Electrical

Input Requirements:

- 10-26 VDC from Greengate Switchpack or Greengate system
- Maximum current needed is 25 mA per sensor
- Adjustable from 180-3 LUX

Output Requirements:

- Open collector output to switch up to ten Greengate Switchpacks
- Isolated Form C Relay Ratings: 1A 30 VDC/VAC

Hardware Specifications

Ambient Light Level Features:

- Adjustable from 180-3 LUX

Status Indicators:

- LED indicators
 - Red LED for PIR detection

Controls and Performance

Technology: Motion Detection Technology

Time delays:

- Auto, 5, 10 and 20 minutes Note: Test mode option set by DIP switch with 15 seconds time delay

Standards/Ratings

- UL Listed

Warranty

Consult website for warranty information

Overview

The Passive Infrared Extreme Temperature sensor provides consistent, stable coverage where extreme heat, cold or humidity must be accommodated and where there are wide fluctuations in temperature. Temperature compensating circuitry stabilizes sensitivity at temperatures -40° F to 125° F (-40° C to 52° C).

Mounting

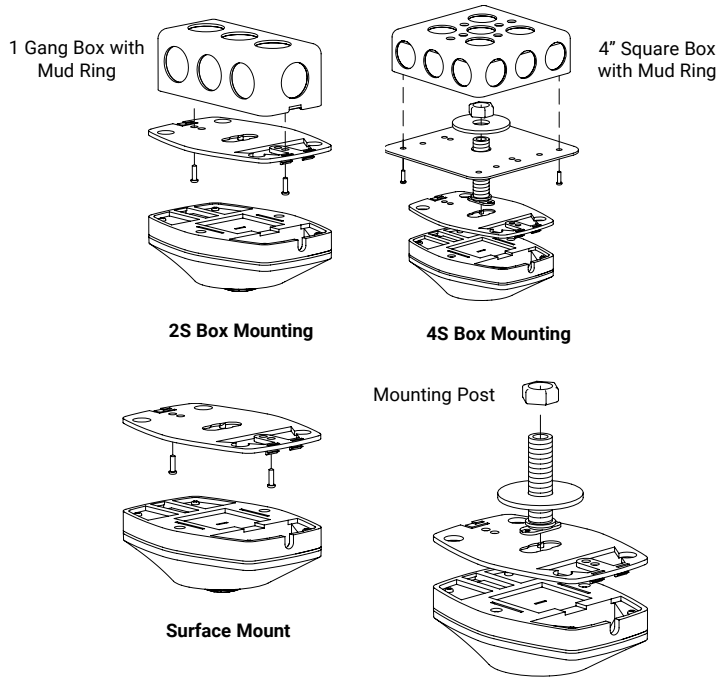

SENSOR: The sensor mounts to normal ceiling tile through a 3/4" hole. The threaded mounting post may be cut down if it is too long to fit into the junction box. The sensor may also be surface mounted or mounted to a standard NEMA 2S or 4S junction box. **CAUTION:** Finger-tighten the nut to avoid stripping the mounting post. Do not apply pressure to Fresnel lens.

BACKPLATE: The sensor can be easily snapped onto or pulled away from the backplate without disturbing the mounting hardware. To pull the sensor away from the backplate, place your fingers on the door on the front of the sensor and slide your fingers up onto the back end of the sensor, with your fingers resting below the edge of the backplate. As you press against the sensor, use your other hand to grip the opposite end of the sensor and pull it away from the backplate.

To snap the sensor back onto the backplate, place the end of the sensor without a door against the backplate first, hooking the edge of the sensor on the two small prongs that extend from the backplate. Press the other end of the sensor against the backplate until it snaps into place.

SWITCHPACK: Designed to be mounted externally to any junction box. When mounted, the line connections are inside the box and the Class 2 wiring exits the rear of the Switchpack housing. In areas where Class 2 wiring is not permitted, the Switchpack can be mounted internally to any standard electrical box.

Wiring Diagram

*Wiring diagram for single sensor application. Visit our website for other wiring diagrams.

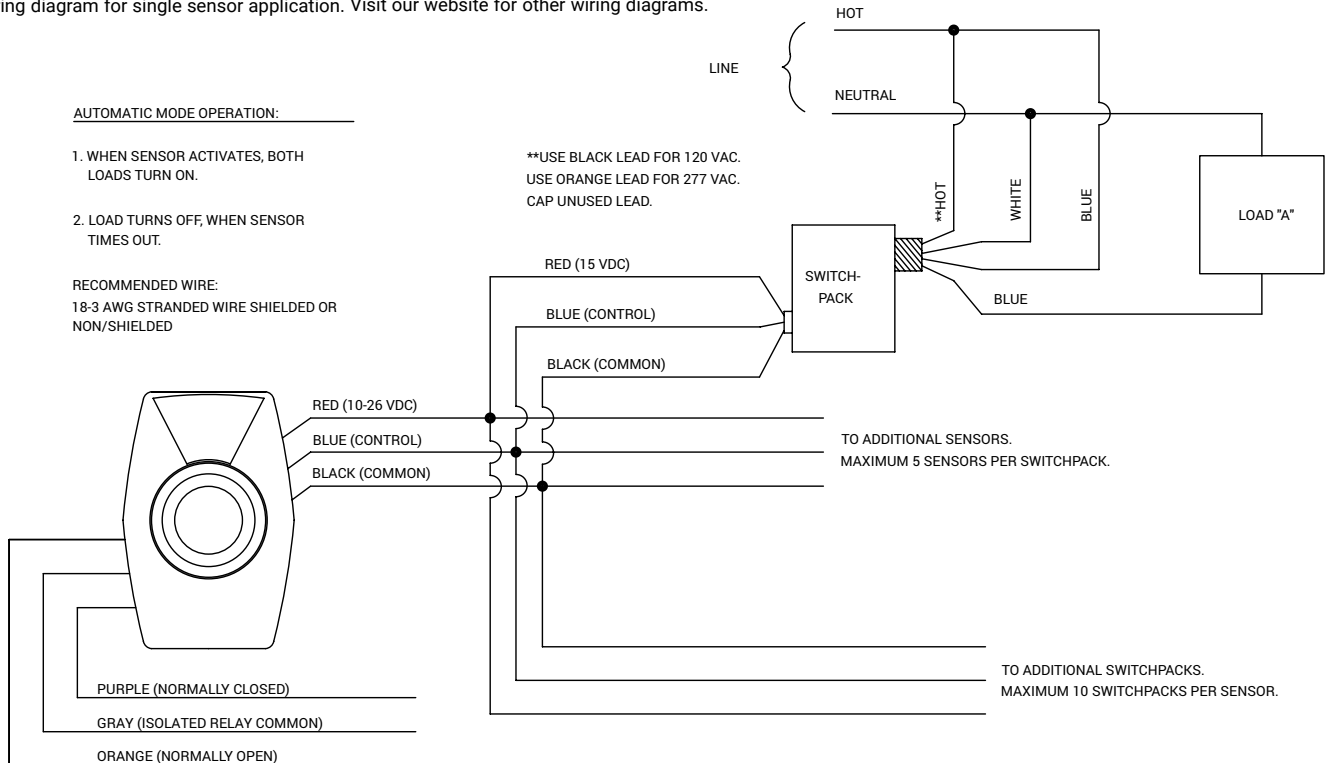

Field of View

TOP VIEW:

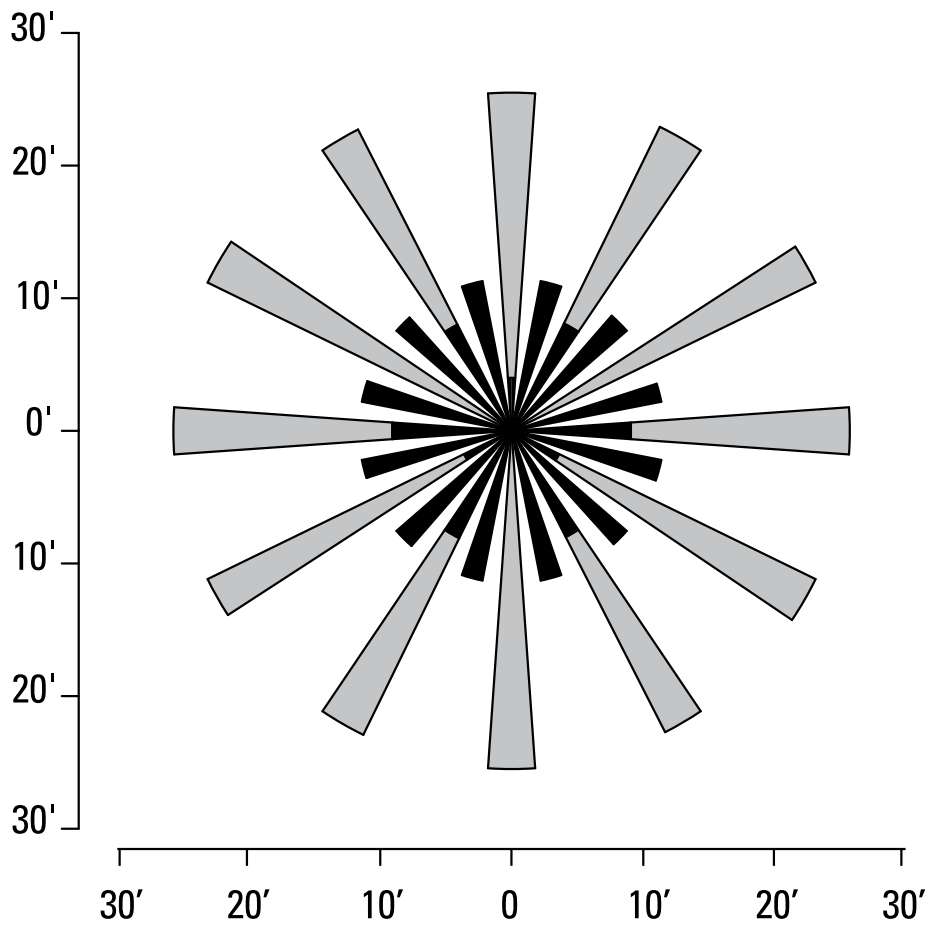

Note: The "beam" pattern obtained depends strongly on the detector used with this array. The pattern shown is intended solely as a general guide and is not to scale.

SIDE VIEW:

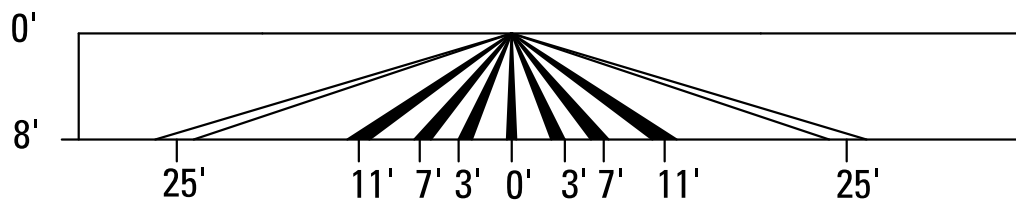

Field of View

TOP VIEW:

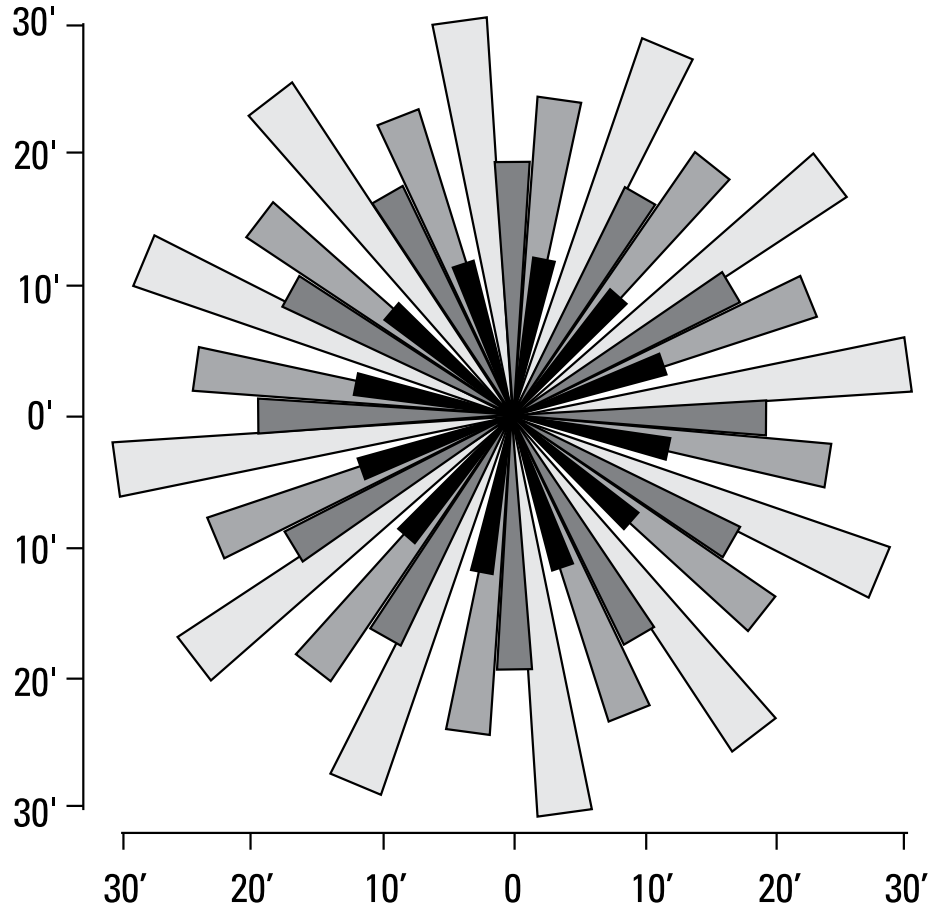

Note: The "beam" pattern obtained depends strongly on the detector used with this array. The pattern shown is intended solely as a general guide and is not to scale.

SIDE VIEW:

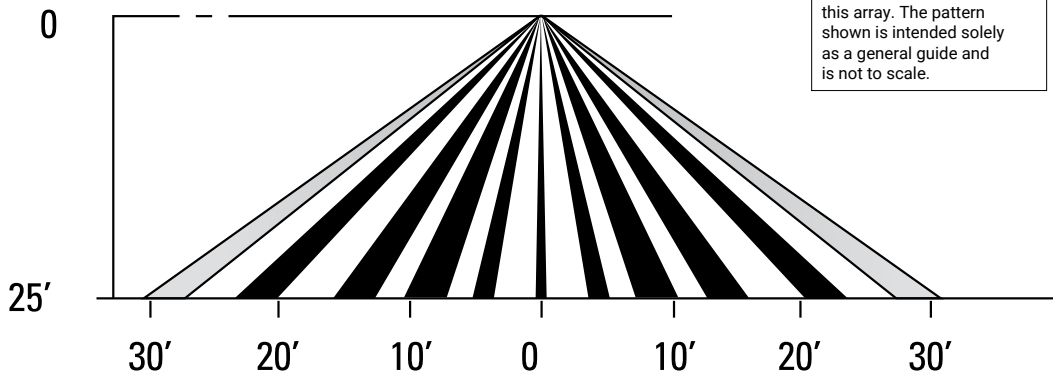

 **Control Systems**

- Greengate