



P/N 9850-000411-01



Model # OXC-P-1500-R
Model # OXC-P-2MH0-R

General Information

- Read all instructions on both sides of this sheet first
- Plan all component locations carefully
- Install in accordance with ALL local codes
- For use with Greengate Switchpacks & Greengate Systems. For use with other systems, contact Technical Support
- For indoor use only
- DO NOT run any Greengate low voltage wiring in the same conduit as power conductors
- UL listed for damp locations

Specifications

Technology: Passive Infrared (PIR)

Power Requirements:

- Input:
- 10-26 VDC from Greengate Switchpack or Greengate system. Maximum current needed is 25mA per sensor

- Output:
- Open collector output to switch up to ten Greengate Switchpacks
 - Isolated Form C Relay (-R model)
 - Isolated Form C Relay Ratings: 1A, 30 VDC/VAC

Time Delays:

- Adjustable time delay

Ambient Light Features:

- Adjustable down to approximately 3 LUX

Operating Environment:

- Temperature: -40° F – 125° F (-40° C – 52° C)
- Relative Humidity: Less than 95% non-condensing
- Indoor or outdoor use

Housing:

- Medium impact injection molded housing. ABS resin complies with UL 94V0. Paintable off-white

Size: 1-5/8"H x 4-1/2"W x 3-1/8"D

(41.3mm x 114.3mm x 79.4mm)

LED Indicators: Red LED for PIR detection

Coverage

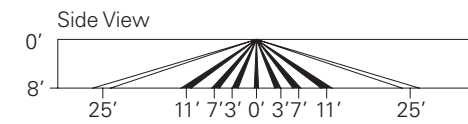
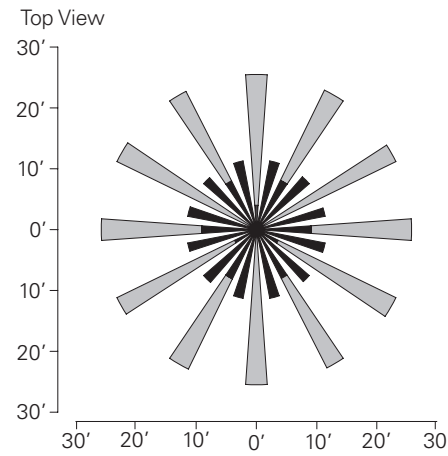

OXC-P-1500-R

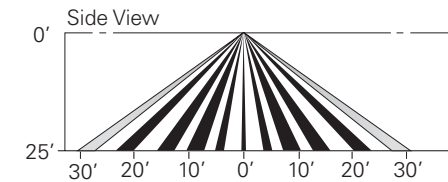
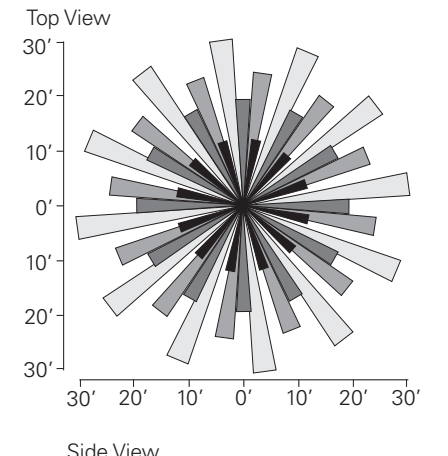

OXC-P-2MH0-R

Location

Note: Model OXC-P-1500-R and OXC-P-2MH0-R is designed specifically for parking structures, cold storage areas, and other applications where extreme temperatures exist. Use Model OXC-P-1500-R in areas up to a maximum of 1,500 square feet of major motion at a mounting height of 8 ft. Coverage of Model OXC-P-2MH0-R is 2MH or twice the mounting height when mounted up to 25 ft. In a warehouse aisle, a sensor mounted at 25 ft will provide coverage for 25 ft in any direction or 50 lin. ft.

Sensor:

Choose sensor location carefully. The sensor must have a clear view of the area to be controlled. There must be an unobstructed line-of-sight from the sensor to any part of the controlled area. For maximum coverage, position the sensor parallel to the longest dimension in the area.

Switchpack:

The switchpack is generally mounted above the ceiling on the outside of the junction box that contains a hot line, neutral and the existing switch leg from which the lighting is controlled. If additional switchpacks are required, they are mounted on the outside of the boxes containing the appropriate switch legs. In installations where there are no existing switch legs, the switchpack may be mounted on the outside of any conventional standard junction box, with or without an extension ring.

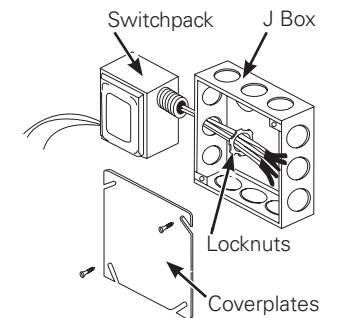

Description

The OXC-P-1500-R Extreme Temperature and OXC-P-2MH0-R Extreme Temperature High Bay Sensor uses passive infrared (PIR) technology with temperature compensating circuitry to control lighting in applications where extreme temperatures/humidity must be tolerated. When motion is detected, the blue wire is electronically connected to the red wire, energizing the relay in the switchpack to turn ON the load. If vacancy is detected, the blue wire is disconnected from the red, causing the relay to open, turning OFF the load. The red lead is +15 VDC supply, the black lead is common, and the blue is the relay control.

Time Delay:

The sensor has selectable time delay options (Auto, 5, 15, 20 minutes)

BAS Interface:

The sensor has an isolated Form C relay for BAS interface.

Ambient Lights Control Circuit:

Use the Ambient Lights controls located on the DIP switch to select the foot-candle level at which ambient light will be sufficient. If ambient light is at the selected level when occupancy is detected, lights will not be activated. The Ambient Lights Control Circuit incorporates a deadband and time delay which ignore brief changes in light levels, such as headlights of a passing car.

Temperature Compensating Circuitry:

Temperature-compensating circuitry stabilizes sensitivity at temperatures from -40° C (-40° F) to 52° C (125° F) to avoid false activations.

Installation

Sensor:

The sensor mounts to normal ceiling tile through a single 3/4" hole. The threaded mounting post may be cut down if it is too long to fit into the junction box. The sensor may also be surface mounted or mounted to a standard NEMA 2S or 4S junction box.

CAUTION: Finger-tighten the nut to avoid stripping the mounting post. Do not apply pressure to Fresnel lens.

Backplate:

The sensor can be easily snapped onto or pulled away from the backplate without disturbing the mounting hardware. To pull the sensor away from the backplate, place your fingers on the door on the front of the sensor and slide your fingers up onto the back end of the sensor, with your fingers resting below the edge of the backplate.

As you press against the sensor, use your other hand to grip the opposite end of the sensor and pull it away from the backplate.

To snap the sensor back onto the backplate, place the end of the sensor without a door against the backplate first, hooking the edge of the sensor on the two small prongs that extend from the backplate. Press the other end of the sensor against the backplate until it snaps into place.

Switchpack:

Designed to be mounted externally to any junction box. When mounted, line connections are inside the box and the Class 2 wiring exits through the rear of the switchpack housing. In areas where Class 2 wiring is not permitted, the switchpack can be mounted internally to any standard electrical box.

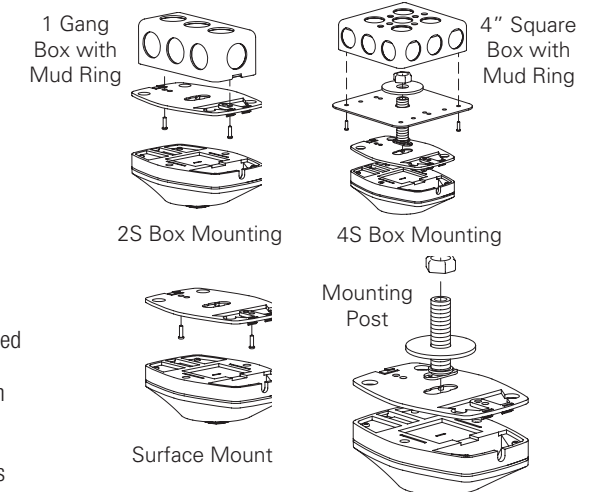

Wiring

CAUTION: OXC-P is for use with 10-26 VDC only. For other voltages, refer to Greengate Spec Sheets. Do not wire to control receptacle circuits. Confirm supply voltage before wiring the switchpack. Make sure the switchpack is the correct model for the voltage being used.

VERIFY that the connected load does not exceed the switchpack ratings. Use twist-on wire connectors for all connections. All installations should be in compliance with the National Electric Code and all state and local codes. DO NOT control more than ten switchpacks with a single sensor.

Greengate sensors are provided with Teflon-insulated pigtailed. The components are interconnected using 18 AWG Class 2 wiring per NEC 725. Use UL-recognized Teflon insulated wire approved for plenum areas per NEC 725-2(b) where required.

Wire the sensor(s), switchpack(s) and load as shown in the Wiring Diagram.

Controlling Multiple Circuits

CAUTION: In situations where an office is wired for multiple circuits using separate hot leads, it is very important to connect only one circuit to each switchpack. You may combine the low voltage wiring from switchpacks connected to different circuits. Consult with the building manager and occupant to determine which lights should be OFF when the toggle switch is open.

AUTOMATIC MODE OPERATION:

1. WHEN SENSOR ACTIVATES, BOTH LOADS TURN ON.
2. LOAD TURNS OFF, WHEN SENSORTIMES OUT.

RECOMMENDED WIRE:
18-3 AWG STRANDED WIRE SHIELDED OR NON/SHIELDED

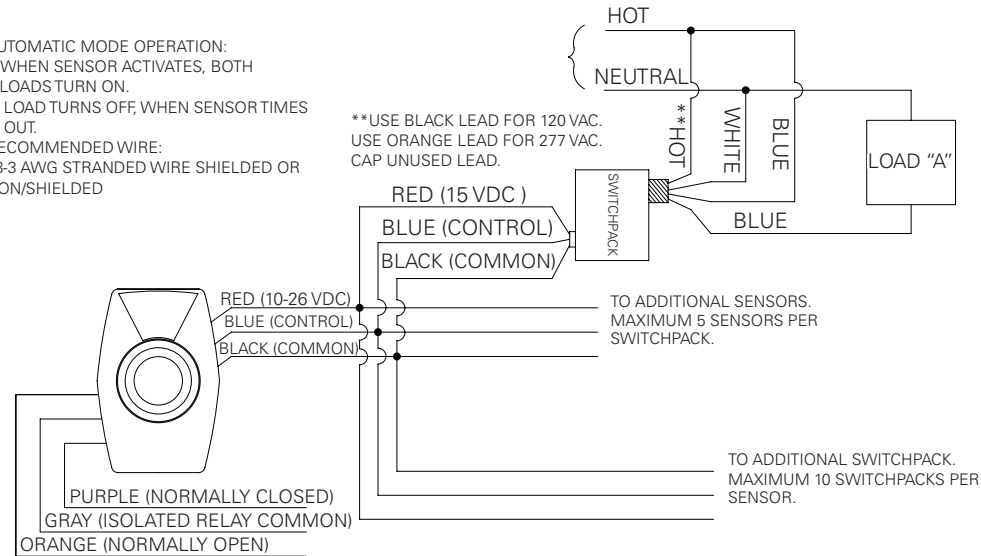

Checkout and Adjustment

1. DIP Switch Controls are located under the door on the face of the sensor. Before opening the door, review factory settings to determine if changes are necessary. The factory setting on all switches is the OFF position. If you elect to change some of these settings, open the door using a screwdriver.
2. Verify that DIP switch 5 is in the off position to ensure the sensor is not in Override Mode.
3. Stand completely still or leave the room. In approximately 15 seconds, the lights will go out.
4. Test the area of coverage by watching the LED on the sensor. The red LED lights when the sensor is detecting motion.
5. Using the chart at right, set the time delay to the desired time for the lights to remain ON after the occupant leaves the covered area. In applications where motion is minor the sensor may need a longer time delay. If the lights go out while the room is occupied, increase the time slightly until optimum time delay is reached.
6. Using the chart below, set the ambient light level. Select the foot-candle level at which ambient light will be sufficient and artificial lighting will be unnecessary. At this level the sensor will not switch lights ON when motion is detected. If you do not want ambient light to impact the sensor, select the OFF setting. If lights go ON when there is adequate ambient light, decrease the footcandle setting.

Manual-ON Override Switch:

The OXC-P-1500-R and OXC-P-2MH0-R has an override DIP switch designed to turn the load ON in the event of sensor failure when the sensor can not be replaced immediately. If the sensor is used with a switchpack, the switchpack must be operative for this switch to work. If the switchpack is defective, it must be replaced or bypassed to activate the load.

To operate, open the DIP switch door on the sensor and move DIP 5 upwards to the ON position. All switchpacks connected to the sensor will now be energized, or the sensor will place a low signal on the blue wire to be sent to a BAS system indicating occupancy. If multiple sensors control the same switchpack(s), activating the override switch on any one sensor will activate all of the switchpacks.

Test Mode:

The sensor can be put into Test Mode to test coverage area. To place the sensor into Test Mode, toggle light level DIP Switch 3 or 4. The sensor LED will blink fast when in Test Mode. Test Mode has a 15 second time-out to allow the user to quickly perform occupancy verification and settings adjustments. To place the sensor back into Normal Operating Mode, toggle a Time Delay DIP Switch. The sensor will also return to normal operation after 10 minutes, regardless of user input.

Troubleshooting

LED will not turn ON

- Verify 10-26 VDC across the red and black wires of the sensor
- If there is no power at the sensor, check for 10-26 VDC at the switchpack output and 120 VAC or 277 VAC at the switchpack input. Verify correct primary connections
- If the voltage is OK at the switchpack, recheck all wiring and connections
- If the LED still doesn't operate, sensor is defective and should be replaced

Lights will not turn ON

- Switch OFF Ambient Lights Control circuit or increase the foot-candle setting
- Confirm that no other switches or equipment are interrupting or bypassing power to the switchpack or load
- Short the blue and red switchpack control leads together to energize the relay
- If the lights turn ON, the sensor is defective and should be replaced
- If the lights do not turn ON, check wiring on the switchpack load side and check switchpack contacts for continuity. Replace the switchpack if necessary

Lights will not turn OFF

In smaller rooms, the sensor may be activated by people moving in the hallway outside the room. Relocate the sensor.

Observe the LED. If it blinks three times every five seconds, the environmental temperature is outside the range of the sensor's temperature compensating circuitry. Sensor will resume normal operation when temperature returns to within -40° C (-40° F) to 52° C (125° F).

If the lights will not turn OFF after the time period set on the sensor, and the LED has not lit during the time period:

- Confirm that no other switches or equipment are interrupting or bypassing power to the switchpack or load
- Verify that the override switch on all sensor circuit boards is in the OFF position
- Check all connections to the switchpack
- Temporarily disconnect the sensor from the switchpack
- If the lights turn OFF, the sensor is defective and should be replaced
- If the lights do not turn OFF, replace the switchpack

NOTE: If multiple sensors/switchpacks are installed, check one at a time.

Warranties and Limitation of Liability

Please refer to www.cooperlighting.com under the Legal section for our terms and conditions.

DIP Switch Settings

DIP Switch	Time Delay		Light Level (FC)			Override	
	1	2	3	4	5		
Auto	▼	▼	OFF	▼	▼	Disable	▼
5	▼	▲	3	▼	▲	Enable	▲
10	▲	▼	5	▲	▼		
20	▲	▲	10	▲	▲		