



### Main

Range of Product	Harmony Electromechanical Relays
Accessory / separate part category	Connection accessories
Product or Component Type	Bus jumper
Sale per indivisible quantity	10

### Complementary

Product compatibility	Socket RXZE14P Socket RSZE05P Socket RXZE08P Socket RGZE05P Socket RGZE08P
[Ith] conventional free air thermal current	2 A
Length	0.73 in (18.5 mm)
Width	0.49 in (12.5 mm)
Height	0.02 in (0.6 mm)
Net Weight	0.00 lb(US) (0.002 kg)

### Ordering and shipping details

Category	21128-ZELIO ICE CUBE RELAY ACCESSORIES
Discount Schedule	CP2
GTIN	3606481465757
Nbr. of units in pkg.	1
Package weight(Lbs)	0.07 oz (2.0 g)
Returnability	No

### Packing Units

Unit Type of Package 1	PCE
Package 1 Height	0.24 in (0.6 cm)
Package 1 width	0.51 in (1.3 cm)
Package 1 Length	0.75 in (1.9 cm)
Unit Type of Package 2	BB1
Number of Units in Package 2	10
Package 2 Weight	0.88 oz (25.0 g)
Package 2 Height	0.39 in (1 cm)
Package 2 width	2.17 in (5.5 cm)
Package 2 Length	3.15 in (8 cm)
Unit Type of Package 3	S01
Number of Units in Package 3	1500
Package 3 Weight	7.05 lb(US) (3.2 kg)
Package 3 Height	5.91 in (15 cm)

Package 3 width	5.91 in (15 cm)
Package 3 Length	15.75 in (40 cm)

## Offer Sustainability

Sustainable offer status	Green Premium product
California proposition 65	WARNING: This product can expose you to chemicals including: Lead and lead compounds, which is known to the State of California to cause cancer and birth defects or other reproductive harm. For more information go to <a href="http://www.P65Warnings.ca.gov">www.P65Warnings.ca.gov</a>
REACH Regulation	<a href="#">REACH Declaration</a>
REACH free of SVHC	Yes
EU RoHS Directive	Pro-active compliance (Product out of EU RoHS legal scope) <a href="#">EU RoHS Declaration</a>
Toxic heavy metal free	Yes
Mercury free	Yes
RoHS exemption information	<a href="#">Yes</a>
China RoHS Regulation	<a href="#">China RoHS Declaration</a>
Environmental Disclosure	<a href="#">Product Environmental Profile</a>
WEEE	The product must be disposed on European Union markets following specific waste collection and never end up in rubbish bins.

## Contractual warranty

Warranty	18 months
----------	-----------

Dimensions

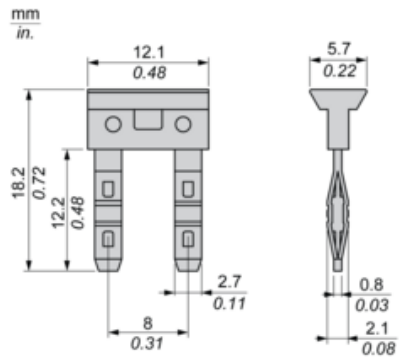

## Wiring

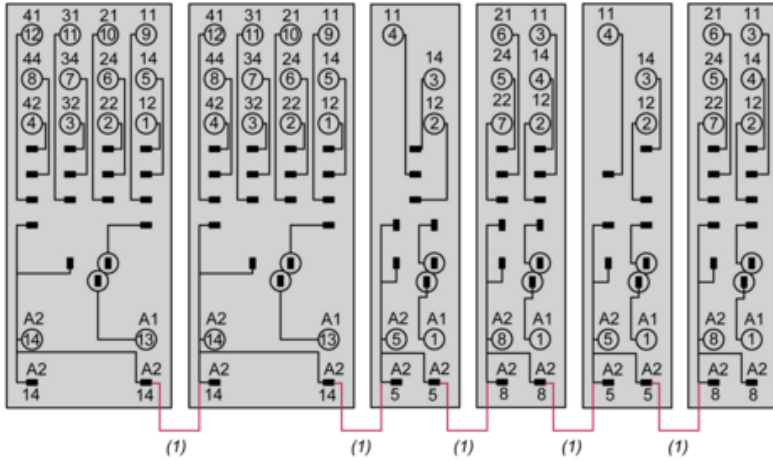

(1) : RSZS02

NOTE: For input A2 only