

TM3SAC5R

Safety module, Modicon TM3 Safety, 1 Function, Cat 3 PL d/SIL CL2 (screw) 24 VDC



Main

Range of Product	Modicon TM3 Safety
Product or Component Type	Safety module
Device short name	TM3SAC
Safety module application	For emergency stop and switch monitoring
Function of module	Emergency stop monitoring 1-channel wiring Emergency stop monitoring 2-channel wiring Monitoring of a movable guard with 2 switches and automatic start
Safety level	Can reach PL d/category 3 EN/ISO 13849-1 2008 Can reach PL d/category 3 EN/ISO 13849-2 2012 Can reach SILCL 2 EN/IEC 62061 2005 Can reach SIL 2 EN/IEC 61508 2010

Complementary

Safety reliability data	DC = 95 % EN/ISO 13849-1 PFHd = 5E-9 1/h IEC 61508-1 1 operation/hour DC-13 24 V DC, <4 A PFHd = 30E-9 1/h IEC 61508-1 60 operations/hour DC-13 24 V DC, <1 A MTTFd = 500 years EN/ISO 13849-1 1 operation/hour DC-13 24 V DC, <4 A MTTFd = 85 years EN/ISO 13849-1 60 operations/hour DC-13 24 V DC, <1 A SFF = 95 % IEC 61508-1 HFT = 1 IEC 61508-1 Type = A IEC 61508-1
Synchronisation time between inputs	Unlimited
Connections - terminals	Captive screw clamp terminals, removable terminal block 1 x 0.2...1 x 2.5 mm ² flexible without cable end 13-14, 23-24, 33-34 Captive screw clamp terminals, removable terminal block 1 x 0.2...1 x 2.5 mm ² solid without cable end 13-14, 23-24, 33-34 Captive screw clamp terminals, removable terminal block 1 x 0.25...1 x 2.5 mm ² flexible with cable end, with bezel 13-14, 23-24, 33-34 Captive screw clamp terminals, removable terminal block 1 x 0.25...1 x 2.5 mm ² flexible with cable end, without bezel 13-14, 23-24, 33-34 Captive screw clamp terminals, removable terminal block 2 x 0.2...2 x 1.5 mm ² flexible without cable end 13-14, 23-24, 33-34 Captive screw clamp terminals, removable terminal block 2 x 0.2...2 x 1.5 mm ² solid without cable end 13-14, 23-24, 33-34 Captive screw clamp terminals, removable terminal block 2 x 0.25...2 x 1 mm ² flexible with cable end, without bezel 13-14, 23-24, 33-34 Captive screw clamp terminals, removable terminal block 2 x 0.5...2 x 1.5 mm ² flexible with cable end, with double bezel 13-14, 23-24, 33-34 Captive screw clamp terminals, removable terminal block 1 x 0.14...1 x 1.5 mm ² flexible without cable end other terminals Captive screw clamp terminals, removable terminal block 1 x 0.14...1 x 1.5 mm ² solid without cable end other terminals Captive screw clamp terminals, removable terminal block 1 x 0.25...1 x 0.5 mm ² flexible with cable end, with bezel other terminals Captive screw clamp terminals, removable terminal block 1 x 0.25...1 x 1.5 mm ² flexible with cable end, without bezel other terminals Captive screw clamp terminals, removable terminal block 2 x 0.14...2 x 0.5 mm ² flexible without cable end other terminals Captive screw clamp terminals, removable terminal block 2 x 0.14...2 x 0.75 mm ² solid without cable end other terminals Captive screw clamp terminals, removable terminal block 2 x 0.25...2 x 0.34 mm ² flexible with cable end, without bezel other terminals Captive screw clamp terminals, removable terminal block 2 x 0.5 mm ² flexible with cable end, with double bezel other terminals
Output type	Relay instantaneous opening, 3 NO, potential free
Number of safety circuits	3 NO relay instantaneous opening
Maximum switching voltage	230 V AC-15 50 Hz relay instantaneous opening) 24 V DC-13 relay instantaneous opening)

The information provided in this documentation contains general descriptions and/or technical characteristics of the performance of the products contained herein. This documentation is not intended as a substitute for and is not to be used for determining suitability or reliability of these products for specific user applications. It is the duty of any such user or integrator to perform the appropriate and complete risk analysis, evaluation and testing of the products with respect to the relevant specific application or use thereof. Neither Schneider Electric Industries SAS nor any of its affiliates or subsidiaries shall be responsible or liable for misuse of the information contained herein.

[Us] rated supply voltage	24 V - 15...20 % DC
Power consumption in W	0.2 W 5 V DC 3.6 W 24 V DC
Input protection type	Internal, electronic
[Uc] control circuit voltage	24 V DC
Maximum cable distance between devices	98.43 ft (30 m)
Breaking capacity	360 VA holding AC-15 B300 relay output 3600 VA inrush AC-15 B300 relay output
Breaking capacity	4 A 24 V 50 ms DC-13 relay output
Output thermal current	6 A per relay relay output
[Ith] conventional free air thermal current	18 A
Associated fuse rating	4 A gG or gL relay output EN/IEC 60947-5-1 6 A fast blow relay output EN/IEC 60947-5-1
Minimum output current	10 mA relay output
Output voltage	10 V relay output
Maximum response time on input open	40 ms
[Ui] rated insulation voltage	300 V 2)IEC 60647-5-1
[Uimp] rated impulse withstand voltage	4 kV III IEC 60647-5-1
Current consumption	100 mA 24 V DC external supply at state on)
Local signalling	For user 6 LEDs (green/red)
Electrical Connection	Screw terminal
Standards	EN/ISO 13849-1:2008 EN/ISO 13849-2:2012 EN/IEC 62061:2005 EN/IEC 61508:2010 EN/IEC 60947-5-1:2010 EN/IEC 61131-2:2007 EN/IEC 60204-1:2005 EN/IEC 60204-1:2009/A1 IEC 61010-1:2010 EN 50581:2012
Product Certifications	TÜV CSA 61010-2-201 (pending) CSA Haz Loc Class 1 Division 2 (pending) RCM ANSI Haz Loc Class 1 Division 2 (pending) EAC UL 61010-2-201
Marking	EFUP 10 RCM CSA UL TÜV CE EAC
Electromagnetic compatibility	Electrostatic discharge immunity test 8 kV air discharge) EN/IEC 61000-4-2 Electrostatic discharge immunity test 6 kV contact discharge) EN/IEC 61000-4-2 Susceptibility to electromagnetic fields 10 V/m 80 MHz to 1 GHz) EN/IEC 61000-4-3 Susceptibility to electromagnetic fields 3 V/m 1.4 GHz...2 GHz) EN/IEC 61000-4-3 Susceptibility to electromagnetic fields 1 V/m 2 GHz...3 GHz) EN/IEC 61000-4-3 Magnetic field at power frequency 30 A/m 50...60 Hz) EN/IEC 61000-4-8 Electrical fast transient/burst immunity test 3 kV power lines (DC)) EN/IEC 61000-4-4 Electrical fast transient/burst immunity test 2 kV I/O) EN/IEC 61000-4-4 1.2/50 µs shock waves immunity test 1 kV power lines (DC)) EN/IEC 61000-4-5 Conducted RF disturbances 10 V 0.15...80 MHz) EN/IEC 61000-4-6 Radiated emission 40 dBµV/m 24 V)class A EN 55011 Radiated emission 47 dBµV/m 24 V)class A EN 55011
Mounting support	Top hat type TH35-7.5 rail IEC 60715 Top hat type TH35-15 rail IEC 60715 Wall mount using attached fasteners
Height	3.70 in (94 mm)
Depth	2.87 in (73 mm)
Width	1.72 in (43.7 mm)
Net Weight	0.42 lb(US) (0.19 kg)

Environment

Standards	EN 1088/ISO 14119 EN/ISO 13850 EN/IEC 60947-1 EN 60204-1 EN/IEC 60947-5-1
Resistance to electrostatic discharge	8 kV in air EN/IEC 61000-4-2 6 kV on contact EN/IEC 61000-4-2
Resistance to electromagnetic fields	9.14 V/m (10 V/m) 80 MHz...1 GHz EN/IEC 61000-4-3 2.74 V/m (3 V/m) 1.4 GHz...2 GHz EN/IEC 61000-4-3 0.91 V/m (1 V/m) 2 GHz...3 GHz EN/IEC 61000-4-3
Resistance to magnetic fields	98.43 A/m (30 A/m) 50/60 Hz EN/IEC 61000-4-8
Resistance to fast transients	3 kV power lines (DC) DC)EN/IEC 61000-4-4 2 kV I/O linesEN/IEC 61000-4-4
Surge withstand	1 kV power lines (DC) differential mode EN/IEC 61000-4-5 DC 1 kV power lines (DC) common mode EN/IEC 61000-4-5 DC
Resistance to conducted disturbances	10 V 0.15...80 MHz EN/IEC 61000-4-6
Electromagnetic emission	Radiated emissions 50 dBµV/m class A 24 V DC)30...230 Hz IEC 61131-3 Radiated emissions 57 dBµV/m class A 24 V DC)230...1000 Hz IEC 61131-3
Ambient Air Temperature for Operation	14...131 °F (-10...55 °C) horizontal installation
Ambient Air Temperature for Storage	-13...158 °F (-25...70 °C)
Relative humidity	10...95 %, without condensation in operation) 10...95 %, without condensation in storage)
IP degree of protection	IP20 terminals)EN/IEC 60529
Pollution degree	2
Operating altitude	0...6561.68 ft (0...2000 m)
Storage altitude	0.00...9842.52 ft (0...3000 m)
Vibration resistance	+/- 3.5 mm 5...150 Hz)IEC 60068-2-6
Shock resistance	15 gn 11 ms IEC 60068-2-27
Mechanical robustness	Bumps 6 ms 300 shocks 25 gn) IEC 60068-2-27

Ordering and shipping details

Category	22533-M2XX PLC & ACCESSORIES
Discount Schedule	MSX
GTIN	3606485392974
Nbr. of units in pkg.	1
Package weight(Lbs)	9.84 oz (279.0 g)
Returnability	No
Country of origin	DE

Packing Units

Unit Type of Package 1	PCE
Package 1 Height	2.95 in (7.5 cm)
Package 1 width	4.17 in (10.6 cm)
Package 1 Length	4.92 in (12.5 cm)
Unit Type of Package 2	S03
Number of Units in Package 2	18
Package 2 Weight	12.17 lb(US) (5.522 kg)
Package 2 Height	11.81 in (30 cm)
Package 2 width	11.81 in (30 cm)
Package 2 Length	15.75 in (40 cm)

Offer Sustainability

Sustainable offer status	Green Premium product
California proposition 65	WARNING: This product can expose you to chemicals including: Lead and lead compounds, which is known to the State of California to cause cancer and birth defects or other reproductive harm. For more information go to www.P65Warnings.ca.gov
REACH Regulation	REACH Declaration
EU RoHS Directive	Pro-active compliance (Product out of EU RoHS legal scope) EU RoHS Declaration
Mercury free	Yes
RoHS exemption information	Yes
China RoHS Regulation	China RoHS Declaration
Environmental Disclosure	Product Environmental Profile
Circularity Profile	End Of Life Information
WEEE	The product must be disposed on European Union markets following specific waste collection and never end up in rubbish bins.
PVC free	Yes

Dimensions

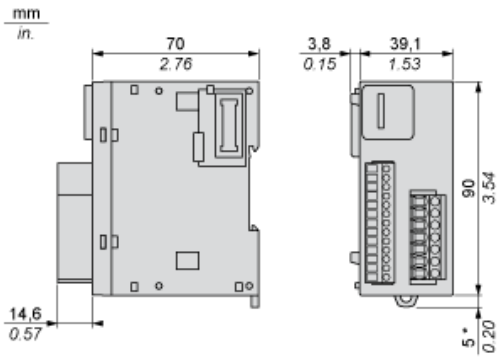

(*) 8.5 mm/0.33 in when the clamp is pulled out.

Spacing Requirements

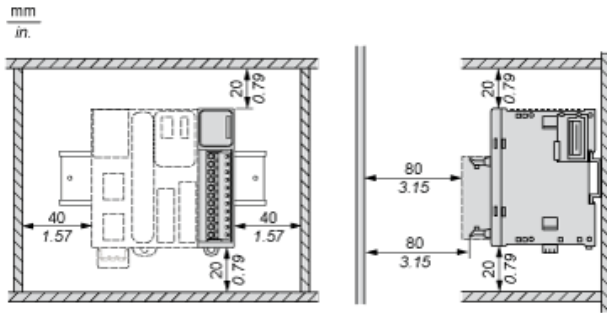

Mounting on a Rail

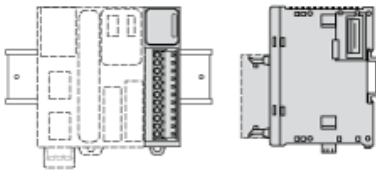

Incorrect Mounting

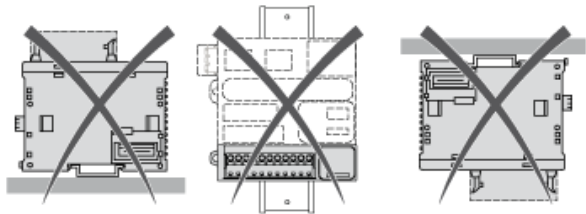

Mounting on a Panel Surface

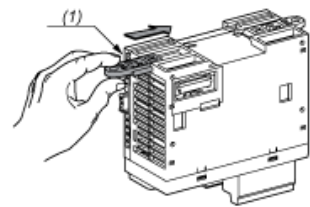

- (1) Install a mounting strip

Mounting Hole Layout

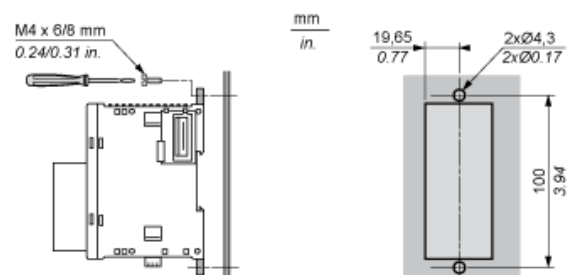

Emergency Stop Wiring Diagram

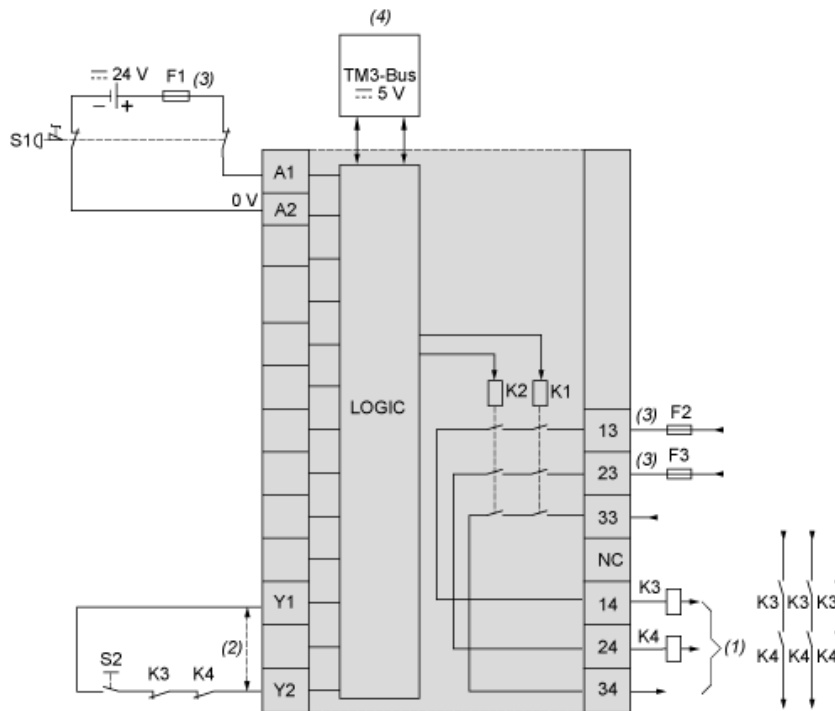

- S1 : Emergency stop switch
- S2 : Start switch
- (1) Safety outputs
- (2) For automatic start, directly connect [Y1] and [Y2] terminals
- (3) Fuses. Refer to technical specifications for fuse values
- (4) Non-safety related TM3 Bus communication with logic controller