

THIS COPY IS PROVIDED ON A RESTRICTED BASIS AND IS NOT TO BE USED IN ANY WAY DETRIMENTAL TO THE INTERESTS OF PANDUIT CORP.

NOTES, UNLESS OTHERWISE SPECIFIED:

1. DIMENSIONS IN BRACKETS ARE IN METRIC.
2. RECOMMENDED TOOL: CT-3001/ST SERIES (A)
3. COMPATIBLE TOOLS: CT-3001/CCP SERIES, CT-930LPCH
4. WIRE SIZE: 3/0
5. CRIMPS: F90 FERRULES - ALL SIZES
6. DIE HALVES ARE HEAT TREATED TO Rc 32-35
7. DIE HALVES ARE NICKLON PLATED FOR LUBRICITY/DURABILITY
8. DIE HALVES AND PLATING ARE RoHS COMPLIANT (A)

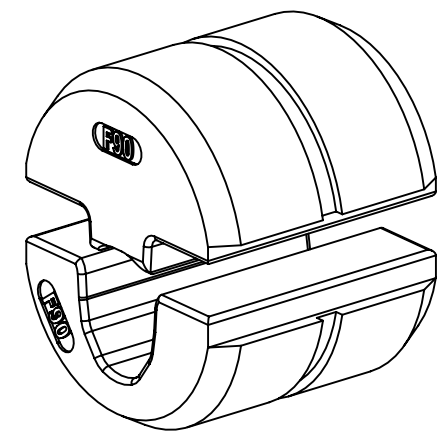
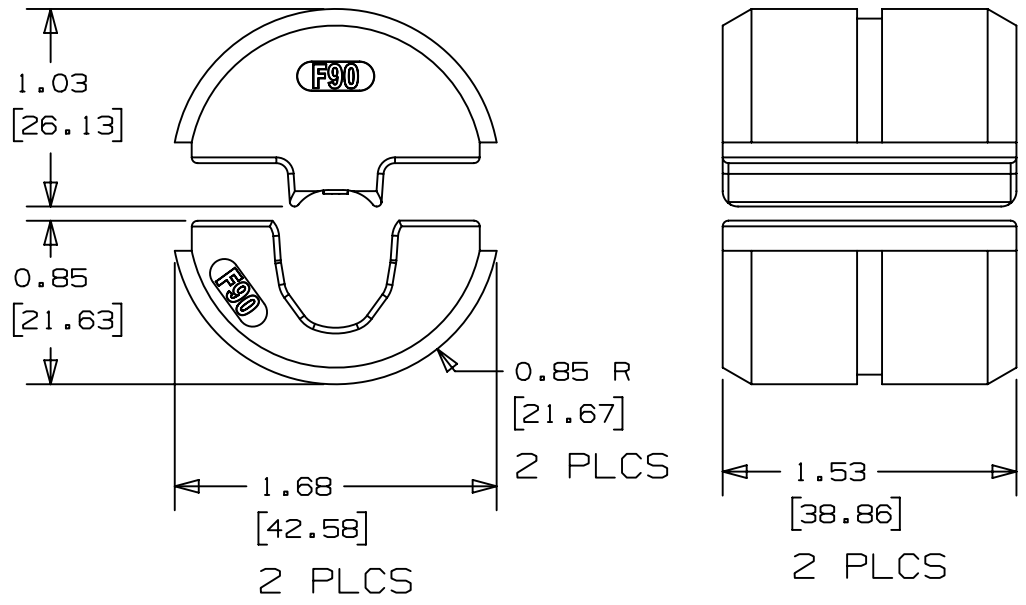

REV	DATE	BY	CHK	APR	DESCRIPTION	ECN
01	11-2-17	BJPU	JEH	JADE	REMOVED CT-2931/ST AND CT-920CH TOOLS, ADDED CT-3001/CCP TOOL, ADDED NOTE #8 (A)	017591
00	03-30-17	BJPU	JEH	JADE	RELEASED	012679

INSTALLATION INSTRUCTION NUMBER PA28870A01		FMEA & CONTROL PLAN NUMBER N/A	
TITLE CD-920-F90 CUSTOMER DRAWING			
CUSTOMER DRAWING			
ITEM REVISION NAME R28876AA/01		PANDUIT	
DATASET FILE NAME R28876AA_DS_TD28876A01/01			
UNLESS OTHERWISE SPECIFIED, DIMENSIONAL TOLERANCES ARE: IN [mm]		MATERIAL: 4140 STEEL / RC 32-35	
.x ± .1 [2.54] .xxx ± .005 [.127]		DRAWING NUMBER: TD28876A01	
.xx ± .01 [.25] ANGLES ± 5 °			
		THIRD ANGLE PROJECTION	
DRAWN BY BJPU	DATE 03/30/17	CHK JADE	SCALE 1:1
SHT 1 OF 1		SIZE A	