

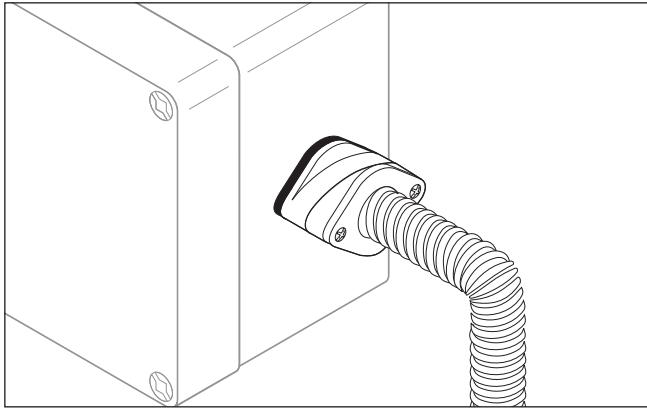

C75-100-A, JBU-100-A(6), JBU-100-L-A

Heating Cable Gland Kit Installation Instructions



DESCRIPTION

The nVent RAYCHEM C75-100-A is a gland kit used to transition heating cables into a junction box when making connections off of a pipe, tank or roof. It may be used for power, splice, or tee connections. The C75-100-A is for use with nVent RAYCHEM BTV-CR, BTV-CT, QTVR-CT, XTV(R), KTV-CT⁽¹⁾, HTV-CT, VPL-CT industrial parallel heating cables and GM-X and GM-XT roof and gutter de-icing heating cables. The kit does not include the junction box, flexible tubing, or tape, which are required to make a complete connection. C75-100-A can also be used in conjunction with JBU-100-A(6), JBU-100-L-A junction boxes. For technical support call nVent at (800) 545-6258.

TOOLS REQUIRED

- Utility knife
- Needle nose pliers
- Wire cutters
- Adjustable pliers
- Marker
- Wire stripper (for VPL)
- 3/16 in (4 mm) or smaller slotted screwdriver
- No. 2 Phillips or 1/4 in (6 mm) slotted screwdriver

ADDITIONAL MATERIALS REQUIRED

- Agency approved NEMA 4X-rated junction box with 3/4-in NPT threaded entry or through hole.
- Tape:
 - GT-66 Installation temperature above 40°F (5°C)
 - GS-54 Installation temperature above -40°F (-40°C)
- One length of flexible tubing, 6 ft (1¾ m) maximum, nVent RAYCHEM HCTE-1000-0 P/N 3679754004
- ⁽¹⁾ For KTV-CT only: Order PMK-GP-10 grommet P/N 700823
- For CSA Zone 1 Hazardous Locations: Zone 1 certified enclosure & DIN rail mounted terminal block.

KIT CONTENTS

Item	Qty	Description
A	1	Red grommet
B	1	Gland with threaded inserts
C	1	Gland with screws
D	1	Gland gasket
E	1	Locknut
F	1	Green/yellow tube
G	1	CS-100 core sealer
H	1	Terminal block

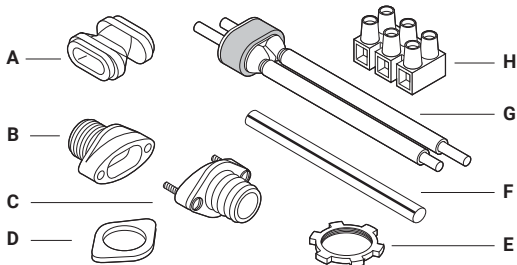

APPROVALS FOR C75-100-A

Hazardous Locations



Class I, Div. 2, Groups A, B, C, D
Class II, Div. 2, Groups F, G
Class III



Class I Division 2 (Zone 2**), Groups A, B, C, D
Class I Zone 2 IIC
IP66



CL I ZN 1 AEx eb IIC T*Gb
CSA02CA1333271X
Ex eb IIC T* Gb

Nonhazardous Locations for GM-X and GM-XT Heating Cable Systems



De-icing and snow
melting equipment



APPROVALS FOR JBU-100-A(6)



CL I ZN 1 AEx eb IIC T* Gb
ZN 21 AEx tb IIIC T**C Db
CSA02CA1333271X
Ex eb IIC T* Gb
Ex tb IIIC T**C Db



Class I Division 2
Group A, B, C, D
Class II, III Group E, F, G
T*
Type 4X



Class I, Division 2 (Zone 2**), Groups A, B, C, D
Class I, Zone 2 IIC
IP66

APPROVALS FOR JBU-100-L-A



CL I ZN 1 AEx eb mb IIC T* Gb
ZN 21 AEx mb tb IIIC T**C Db
CSA02CA1333271X
Ex eb mb IIC T* Gb
Ex mb tb IIIC T**C Db



Class I Division 2
Group A, B, C, D
Class II, III Group E, F, G
T*
Type 4X



Class I, Division 2 (Zone 2**), Groups A, B, C, D
Class I, Zone 2 IIC
IP66

(1) Except HTV (2) Except HTV and VPL (3) For HTV-CT only. ** Per CE Code Table 18

WARNING:

This component is an electrical device that must be installed correctly to ensure proper operation and to prevent shock or fire. Read these important warnings and carefully follow all of the installation instructions.

- To minimize the danger of fire from sustained electrical arcing if the heating cable is damaged or improperly installed, and to comply with the requirements of nVent, agency certifications, and the national electrical codes, ground-fault equipment protection must be used. Arcing may not be stopped by conventional circuit breakers.
- Component approvals and performance are based on the use of nVent-specified parts only. Do not use substitute parts or vinyl electrical tape.
- The black heating cable core is conductive and can short. They must be properly insulated and kept dry.
- Damaged bus wires can overheat or short. Do not break bus wire strands when scoring the jacket or core.
- Keep components and heating cable ends dry before and during installation.
- Use only fire-resistant insulation materials, such as fiberglass wrap or flame-retardant foam.

AVERTISSEMENT :

Ce composant électrique doit être installé correctement pour éviter les risques d'incendie ou de chocs électriques. Lire ces avertissements importants et suivre attentivement toutes les instructions d'installation.

- Pour réduire le danger d'incendie causé par un arc électrique entretenu, si le câble chauffant est endommagé ou mal installé, et pour respecter les exigences de nVent et celles des codes applicables, il est impératif d'utiliser une protection par disjoncteur différentiel. Les disjoncteurs ordinaires ne sont pas toujours capables de supprimer les arcs électriques.
- Les approbations et les performances des composants sont basées sur l'utilisation des pièces nVent spécifiées seulement. N'utilisez pas de pièces de rechange ou de ruban isolant en vinyle.
- Le noyau et les fibres du câble chauffant noir sont conducteurs et peuvent provoquer un court-circuit. Ils doivent être correctement isolés et gardés à sec.
- Les fils omnibus endommagés peuvent surchauffer ou subir un court-circuit.
- Ne brisez jamais les fils omnibus lorsque vous incisez la gaine ou le noyau.
- Maintenez les composants et les extrémités des câbles chauffants secs avant et pendant l'installation.
- Les fils omnibus peuvent provoquer un court-circuit s'ils se touchent. Les garder à l'écart les uns des autres
- N'utilisez que des matériaux isolants ininflammables, par exemple une gaine de fibre de verre ou de la mousse ignifuge.
- Laissez ces instructions d'installation à l'utilisateur pour qu'il puisse les consulter.

CAUTION:

HEALTH HAZARD: Prolonged or repeated contact with the sealant in the core sealer may cause skin irritation. Wash hands thoroughly. Overheating or burning the sealant will produce fumes that may cause polymer fume fever. Avoid contamination of cigarettes or tobacco. Consult MSDS VEN0033 for further information.

CHEMTREC 24-hour emergency telephone: (800) 424-9300

Non-emergency health and safety information: (800) 545-6258.

MISE EN GARDE :

DANGER POUR LA SANTÉ : Le contact prolongé ou répété avec le produit d'étanchéité du noyau peut provoquer une irritation de la peau. Lavez-vous les mains soigneusement. La surchauffe et la combustion du produit d'étanchéité produira des vapeurs qui peuvent causer la fièvre des vapeurs de polymères. Évitez la contamination des cigarettes ou du tabac. Consultez la fiche technique santé-sécurité (FTSS) VEN 0033 pour obtenir de plus amples informations.

Téléphone en cas d'urgence 24 heures sur 24 de CHEMTREC : (800) 424-9300

Renseignements non urgents en matière de santé et de sécurité : (800) 545-6258

Heating Cable Types

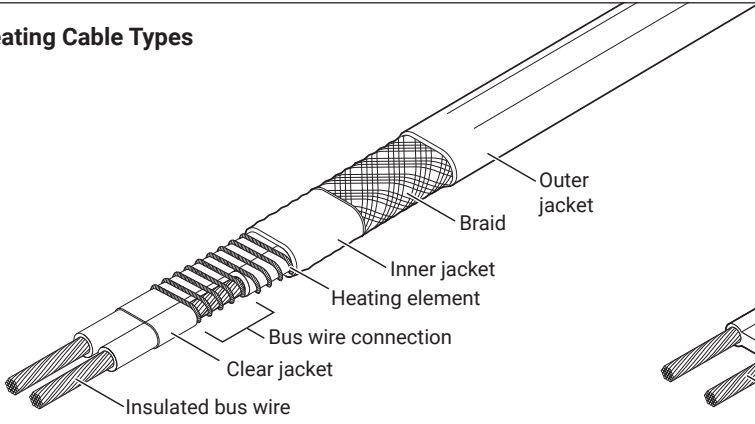

VPL-CT

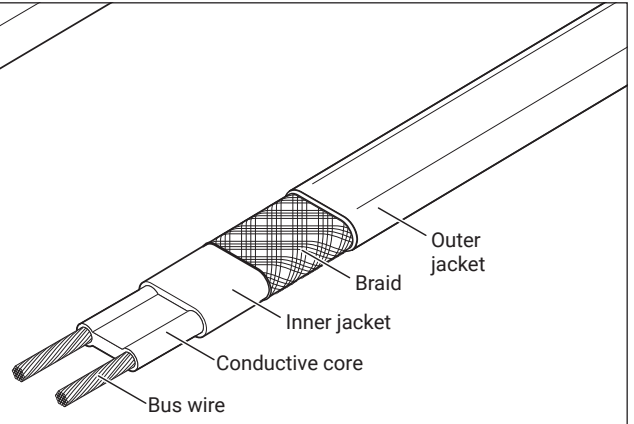

BTV-CR, BTV-CT, QTVR-CT, GM-X, GM-XT

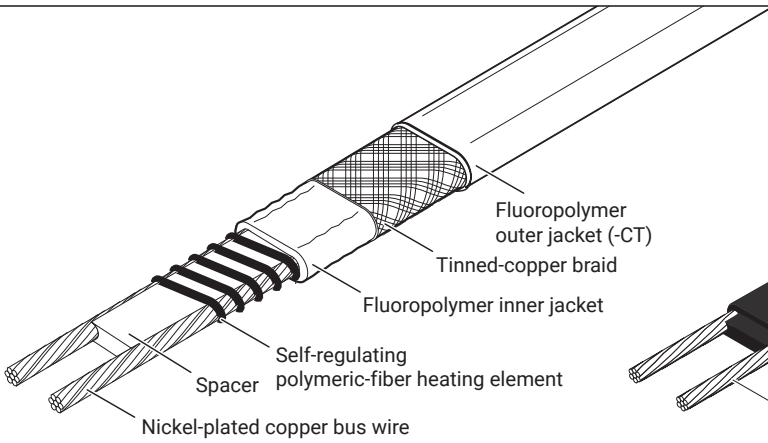

XTV(R), KTV-CT

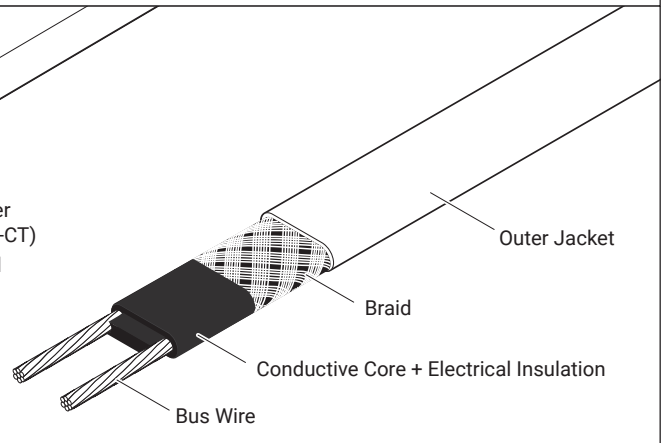

HTV-CT

1

- Select correct grommet from the chart below.

Heating Cable	Grommet
HTV-CT, GM-X, GM-XT, BTV-CR, BTV-CT, QTVR-CT, VPL-CT, XTV(R)	Red
KTV-CT	P*

* Order separately

⚠ WARNING: Use of the wrong grommet can result in leaks, cracked components, shock or fire, and will invalidate approvals and certifications.

⚠ AVERTISSEMENT : L'utilisation du mauvais passe-fil peut entraîner des fuites, la fissuration des composants, l'électrocution ou un incendie et invalide les homologation et certifications.

2A For threaded junction boxes

- For VPL heating cables only: Cut heating cable 12 in (30 cm) from the center of the first indentation (bus wire connection).

- Slide heating cable through gland and box until it extends 15 in (40 cm) beyond outside edge of box as shown.

- Mount box on wall or bracket.
- Install gland with threaded inserts into hub.
- Slide parts onto heating cable.

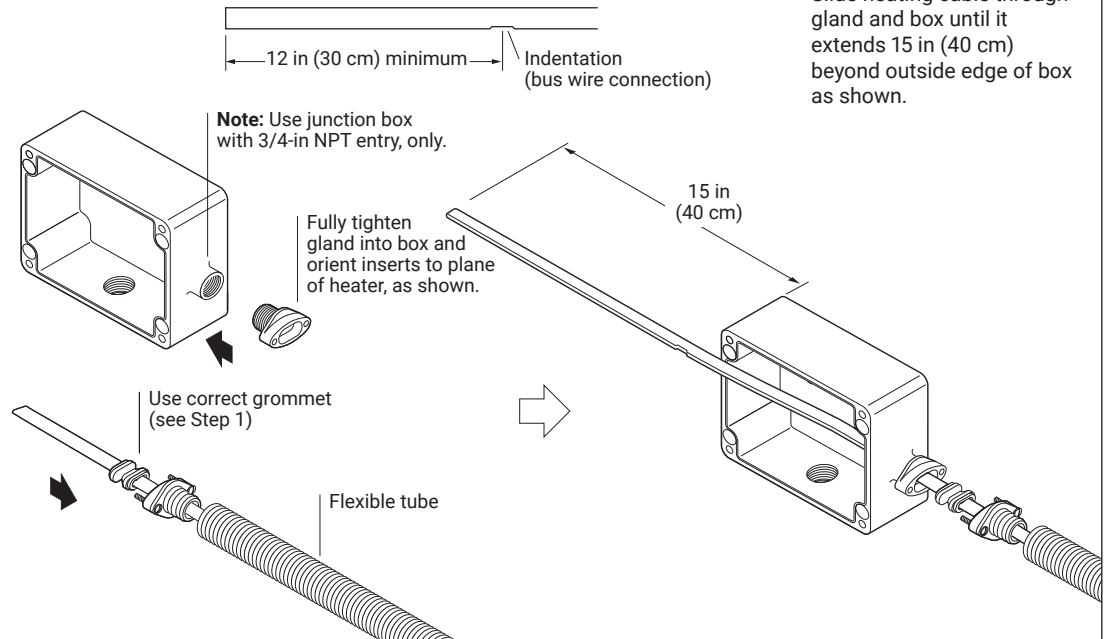

2B For through hole junction boxes

- For VPL heating cables only:
Cut heating cable 12 in (30 cm) from the center of the first indentation (bus wire connection).

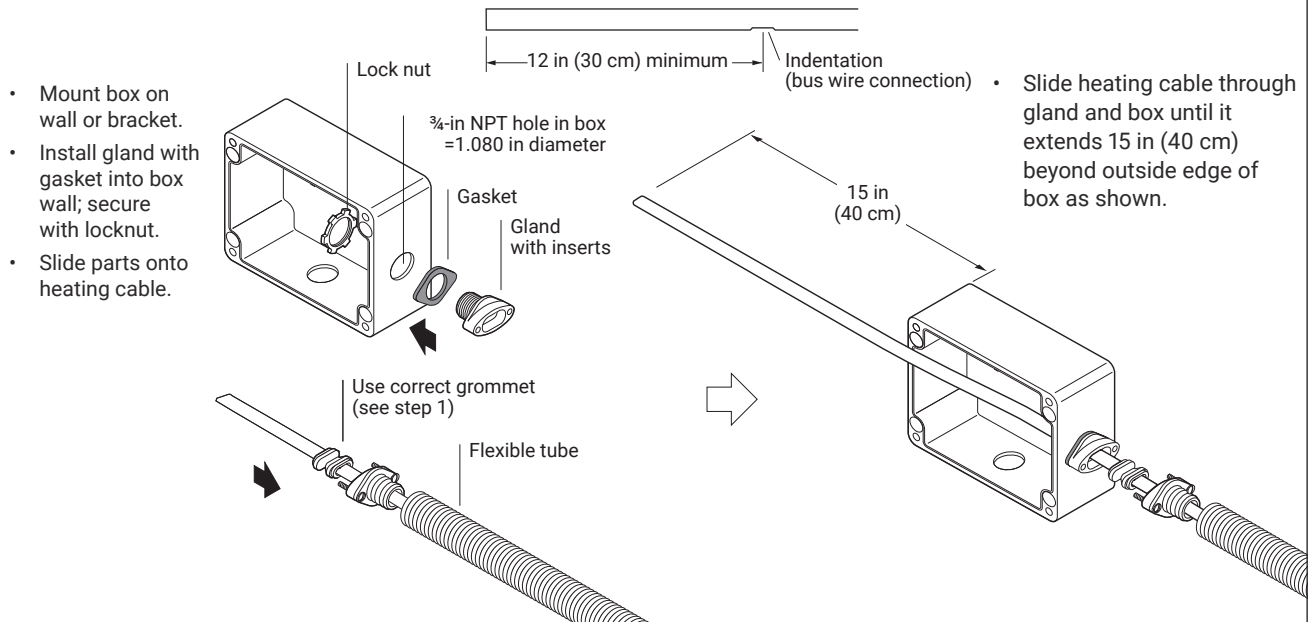

2C For GM-X, GM-XT and threaded junction boxes (outdoor location)

Note: If your installation requires that the heating cable be installed in flexible conduit as shown in 14b, add the appropriate amount of heating cable.

- Thread the cap of the Y fitting with 3/4-in NPT entry.
- Thread the gland fitting without the captive screws into the cap of the Y fitting.
- Slide parts onto heating cable.

⚠ WARNING: Prevent mechanical damage. When installed as shown, the junction box is supported by a non-metallic mounting gland. This method may only be used where the box is not exposed to mechanical stress, static loads, or impact. Protect it with a shield or mount it out of the reach of people or moving equipment.

⚠ AVERTISSEMENT : prévention des dommages mécaniques. Lorsqu'il est installé comme sur l'image, le boîtier de raccordement est supporté par un presse-étoupe de montage non métallique. Cette méthode doit être utilisée seulement là où le boîtier n'est pas exposé à des contraintes mécaniques, des charges statique, ou impact. Protéger le boîtier avec un blindage ou installer le hors de portée des gens ou des équipements mobiles.

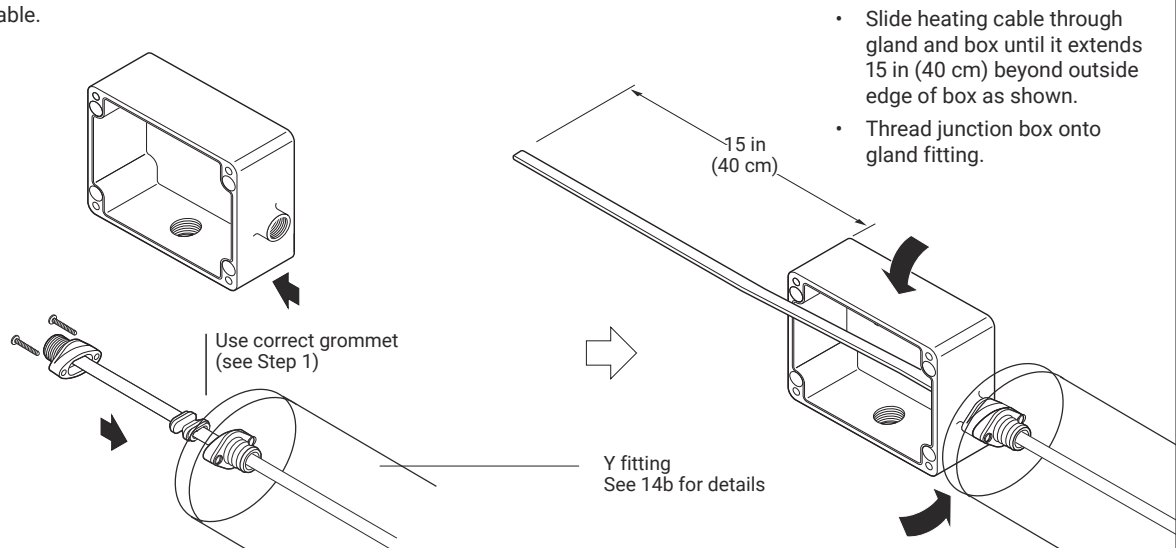

2D For GM-X, GM-XT and through hole junction boxes (indoor dry location)

Note: If your installation requires that the heating cable be installed in flexible conduit as shown in 14C, add the appropriate amount of heating cable.

⚠ WARNING: Prevent mechanical damage. When installed as shown, the junction box is supported by a non-metallic mounting gland. This method may only be used where the box is not exposed to mechanical stress, static loads, or impact. Protect it with a shield or mount it out of the reach of people or moving equipment.

⚠ AVERTISSEMENT : prévention des dommages mécaniques. Lorsqu'il est installé comme sur l'image, le boîtier de raccordement est supporté par un presse-étoupe de montage non métallique. Cette méthode doit être utilisée seulement là où le boîtier n'est pas exposé à des contraintes mécaniques, des charges statique, ou impact. Protéger le boîtier avec un blindage ou installer le hors de portée des gens ou des équipements mobiles.

- Slide parts onto heating cable in the sequence and orientation shown.
- Bring the Y fitting part together and tighten the two screws.
- Slide the gasket threaded end with captive screw.
- Insert thread end into box entry hole and loosely tighten lock nut.

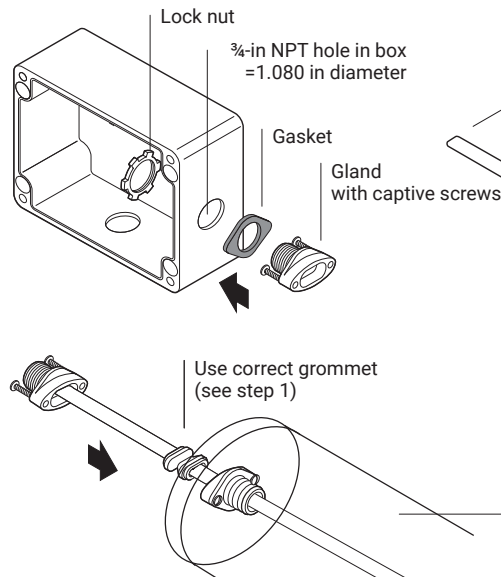

- Slide heating cable through gland and box until it extends 15 in (40 cm) beyond outside edge of box as shown.
- Tighten lock nut to junction box on gland fitting.

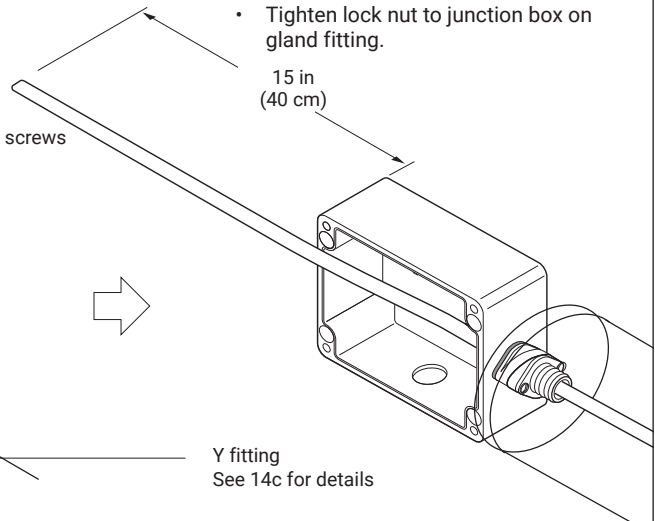

3

- Lightly score outer jacket around and down as shown.
- Bend heating cable to break jacket at score, then peel off jacket.

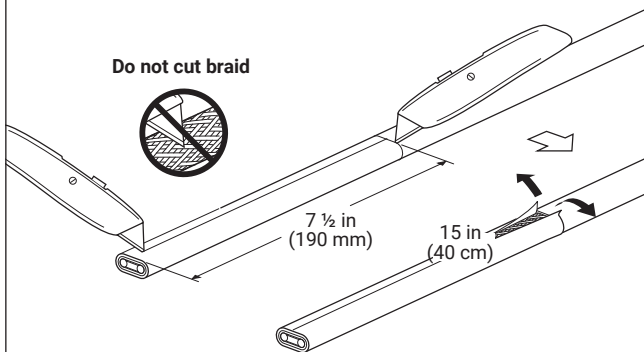

4

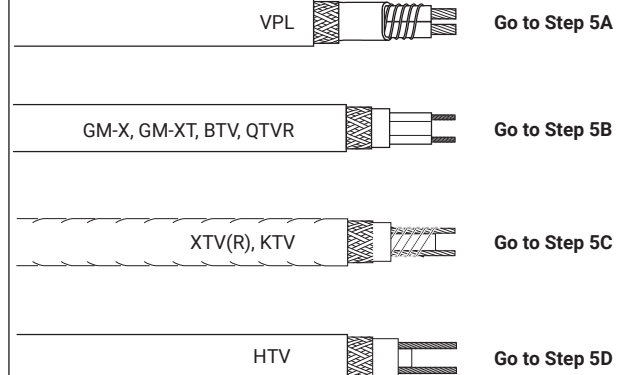

5A

VPL

- Push braid back and bunch as tight as possible.

- Lightly score inner jacket around and down as shown.

- Peel off inner jacket.

- Unwind heating element, cut and remove as shown.

- Lightly score clear jacket around and down as shown.

- Bend heating cable to break jacket at the score then peel off jacket.

- Push braid forward. Use a screwdriver to open braid as shown.

- Bend heating cable and work it through opening in braid.

- Remove insulation from ends of bus wires.

- Pull braid tight to make pigtail.

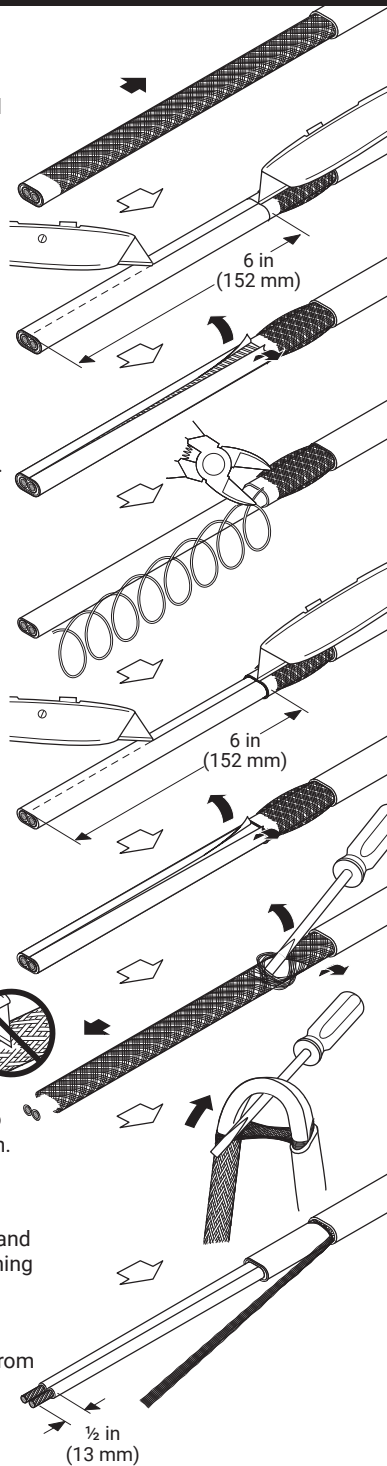

Go to Step 6

5B

GM-X, GM-XT, BTV, QTVR

- Push braid back to create a pucker.

- At pucker use a screwdriver to open braid.

- Bend heating cable and work it through opening in braid.

- Lightly score base jacket around and down as shown.

- Peel off base jacket.

- Notch core.

- Peel bus wire from core.

- Score core between bus wires at inner jacket.

- Bend and snap core.

- Peel core from bus wire.

- Remove any remaining core material from bus wires.

- Pull braid tight to make pigtail.

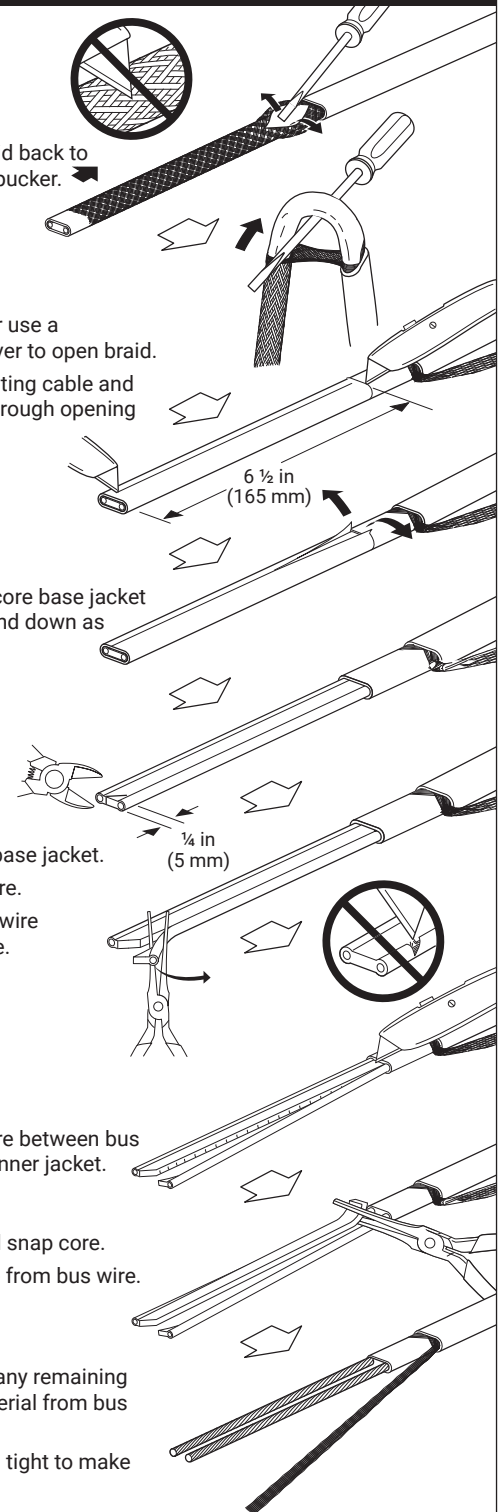

Go to Step 6

5C

KTV, XTV(R)

- Push braid back to create a pucker.

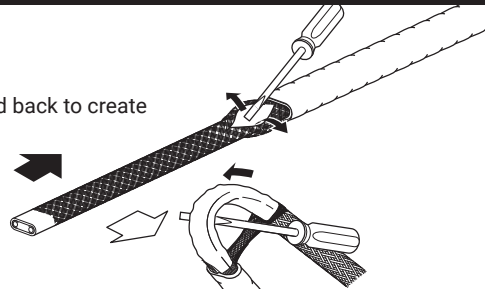

- At pucker use a screwdriver to open braid.
- Bend heating cable and work it through opening in braid.



- Lightly score base jacket around and down as shown.

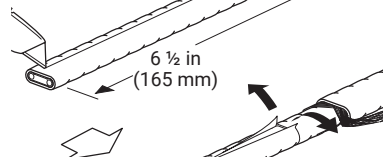

- Peel off base jacket.



- Notch core.
- Cut and remove all fiber strands.

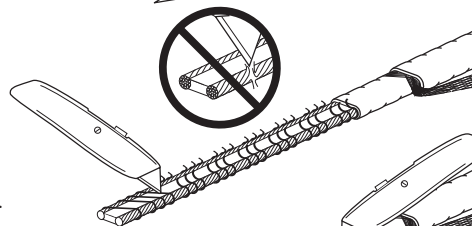

- Score and remove center spacer.
- Bend and snap core.

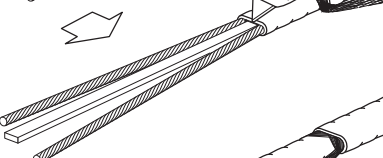

- Remove any remaining fiber material from bus wires.

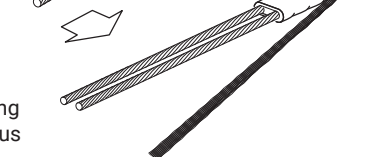

- Pull braid tight to make pigtail.



Go to Step 6

5D

HTV

- Push braid back to create a pucker.
- At pucker use a screwdriver to open braid.

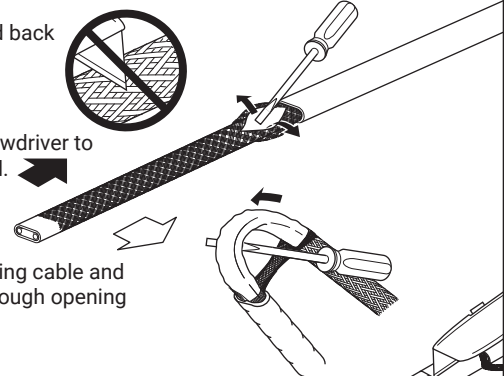

- Bend heating cable and work it through opening in braid.

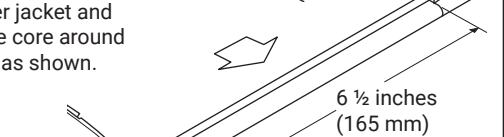

- Score inner jacket and conductive core around and down as shown.



- Peel off inner jacket.

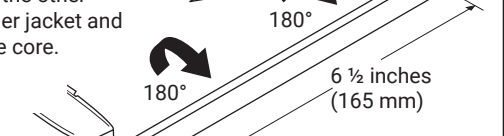

- Flip the cable 180° and score the other side of inner jacket and conductive core.

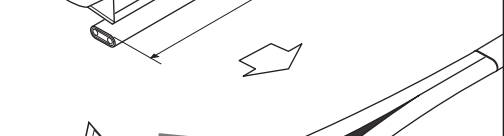

- Remove the inner jacket, conductive core by using needle-nose pliers as shown.
- Score and remove center insulation.

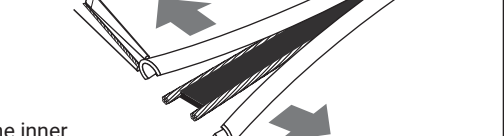

- Remove any remaining material from bus wires.
- Pull braid tight to make pigtail.

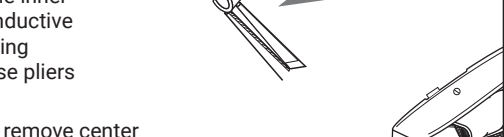

Go to Step 6

6

- Mark the jacket as shown.

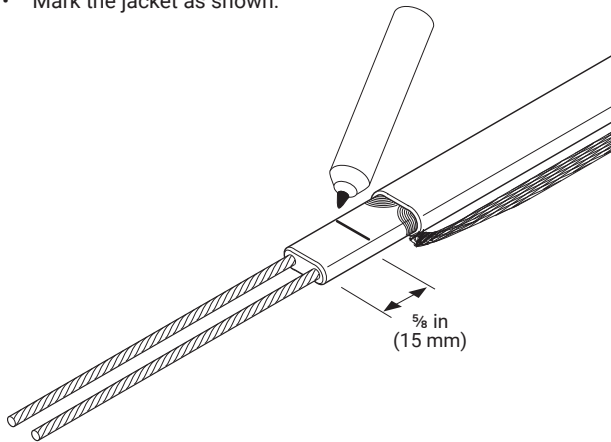

7

⚠ CAUTION: Health Hazard.
Wash hands after contact with sealant. Consult material safety data sheet VEN0033.

⚠ AVERTISSEMENT : risque pour la santé. Se laver les mains après tout contact avec le produit d'étanchéité. Consulter la fiche de données de sécurité VEN 0033.

- If needed, re-twist and straighten bus wires, then insert into the guide tubes as shown.

Make sure all strands go into the tubes.

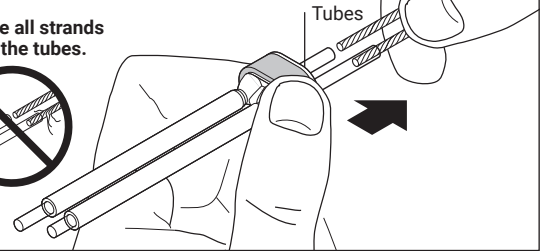

8

- Push core sealer onto the heating cable to the mark made in Step 6.
- Extra force may be required for larger cables or at lower temperatures.

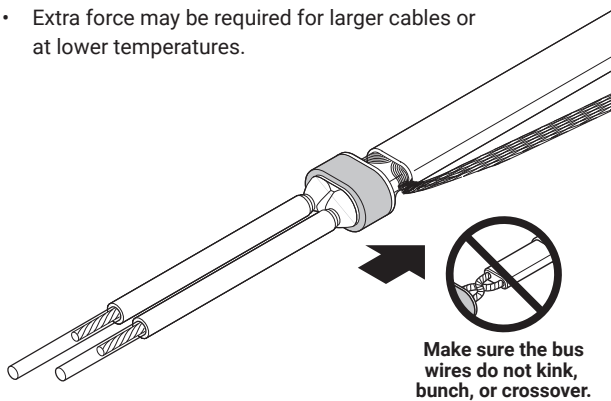

Make sure the bus wires do not kink, bunch, or crossover.

9

- Remove the guide tubes and dispose of them in a plastic bag.

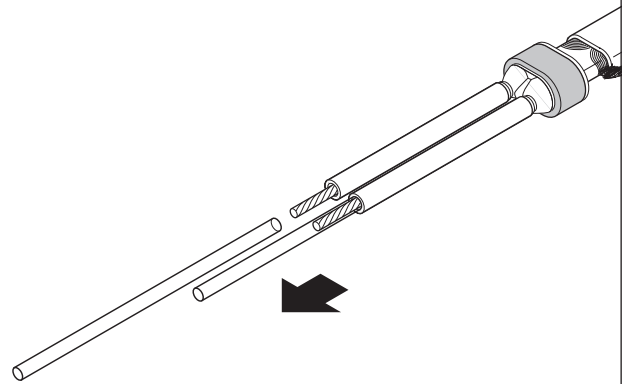

10

- Apply 3 wraps of glass tape (nVent RAYCHEM GT-66 or GS-54).
- Slip the green/yellow tube onto the braid. Heat shrinking is not required.

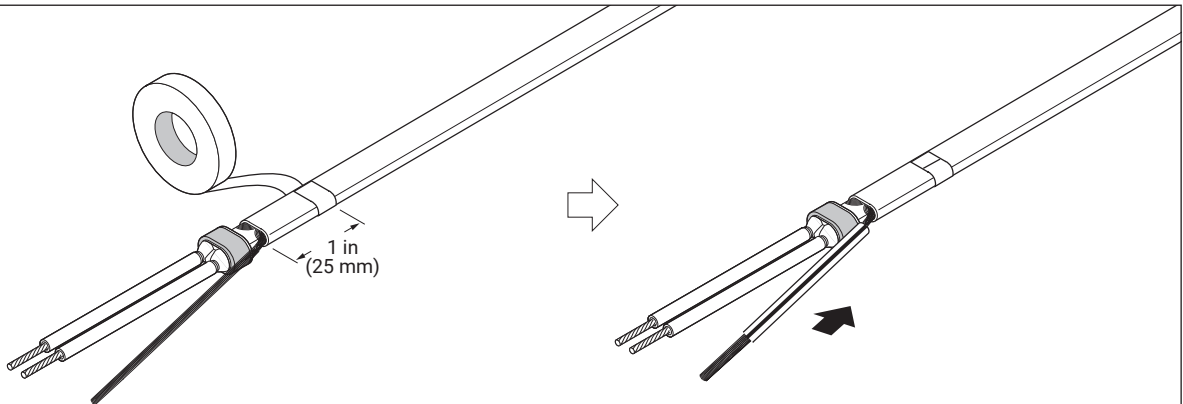

11A For threaded hole junction boxes

- Pull cable back through gland and box until tape is located just inside hub.
- Seat grommet in gland as shown.
- Position gland with screws next to grommet and tighten screws.
- Thread flexible tube onto gland.
- Install conduit and pull in power and ground wires for power connections.

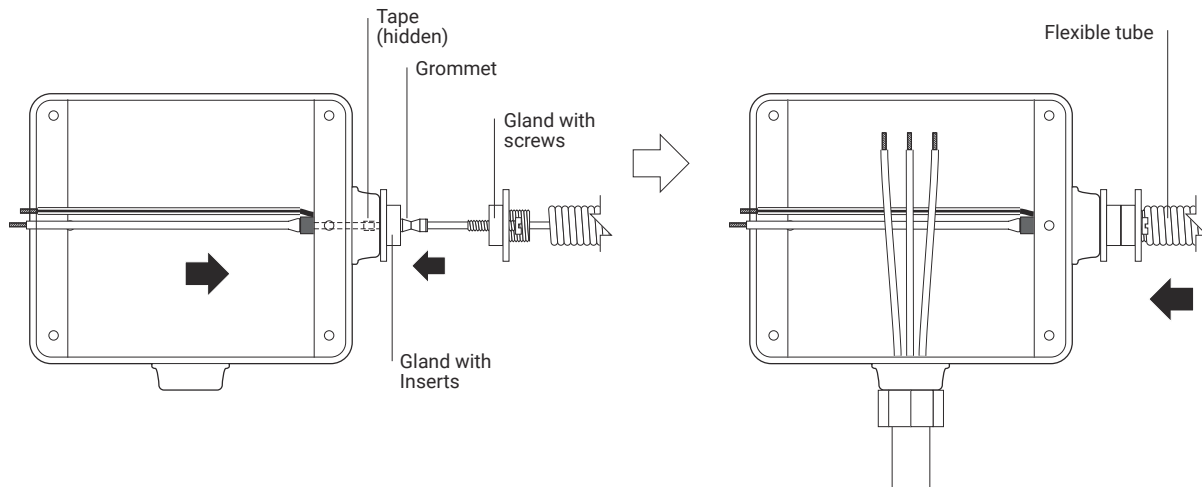

11B For through hole junction boxes (e.g. JBU-100-A, JBU-100-L-A, JBU-100-A6)

- Pull cable back through gland and box until tape is located just inside gland with inserts.
- Seat grommet in gland as shown.
- Position gland with screws next to grommet and tighten screws.
- Thread flexible tube onto gland.
- Install conduit and pull in power and ground wires for power connections.

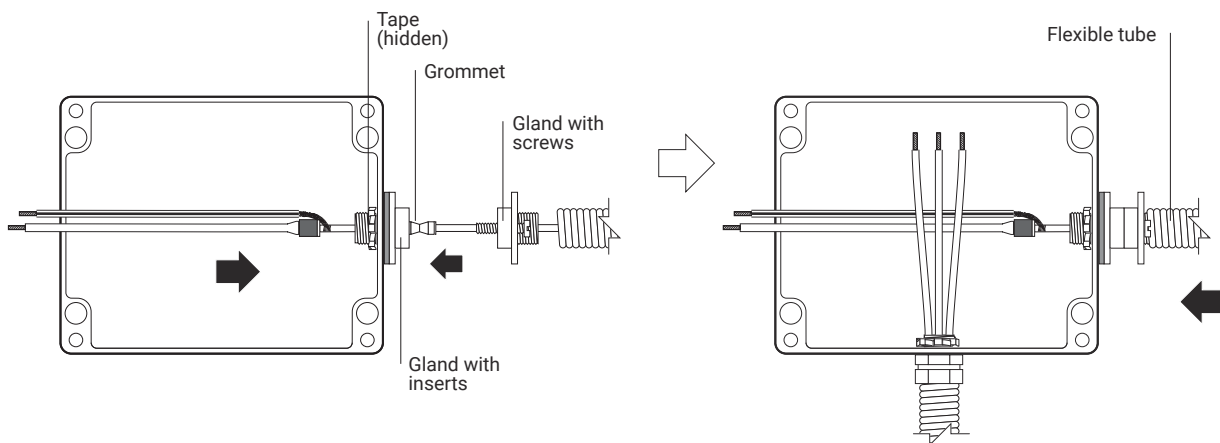

11C For JBU-100-A, JBU-100-A6, JBU-100-L-A

This kit uses spring clamp terminals.

Terminals use a steel spring to clamp the wire to provide improved vibration resistance, reduced maintenance and faster installation.

To connect wires, firmly insert a slotted screwdriver into the square hole (Ⓛ) to open the spring. When fully inserted, the screwdriver will lock into place, allowing you to remove your hand and insert the wire into the round hole (Ⓞ). Remove the screwdriver to clamp the wire. The wire is held securely against the bus bar for low contact resistance over time without the need to periodically retighten screws.

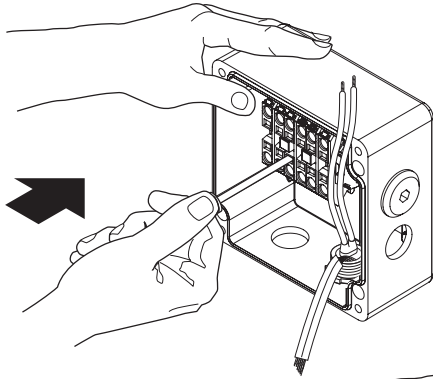

- Push screwdriver **FIRMLY** into square hole.

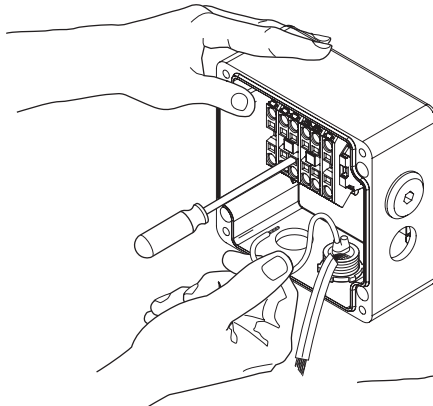

- Insert wire into round hole.
- Use green terminal for braid and ground wire.

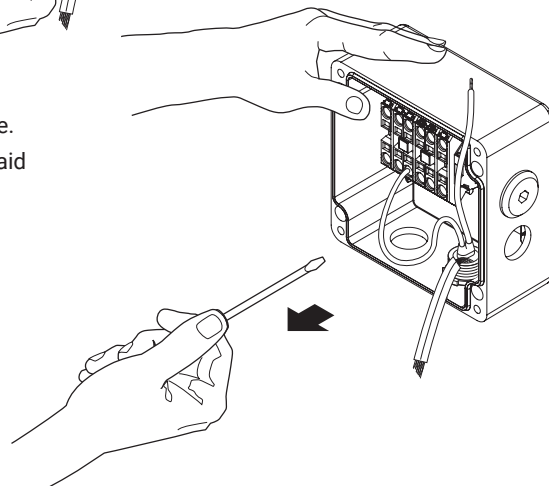
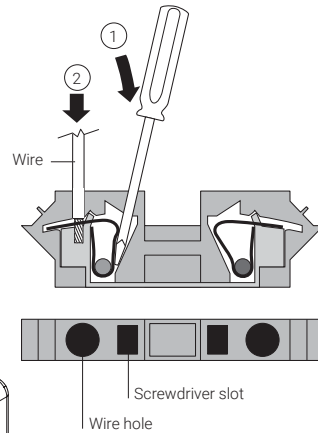

- Remove screwdriver.
- Repeat for all connections.

12

Note the following instructions on bus wire preparation:

For tee, install two wires in one terminal:

- Twist appropriate wire pair together.
- Trim twisted wires to $\frac{1}{2}$ in (13 mm).

Otherwise, trim single wires to $\frac{3}{8}$ in (10 mm).

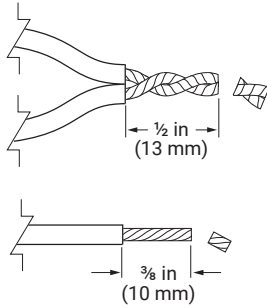

Note: For CSA certified Zone 1 DIN rail mounted terminal blocks, install bus wire in accordance with manufacturer's specifications.

13 For other junction boxes

- Connect bus wires and braid to terminal block.
- Connect power wires and ground wire to terminal block for power connections. This connection must be protected by a ground-fault equipment protection device.

Note: For CSA Zone 1 hazardous locations, discard terminal block supplied with the C75-100-A kit & use a CSA certified Zone 1 DIN rail mounted terminal block.

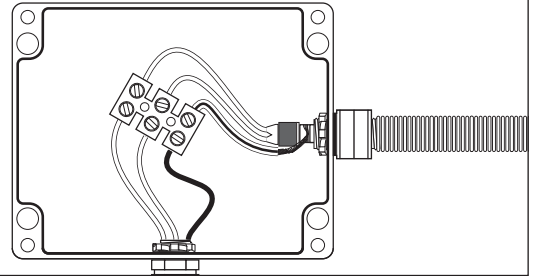
**14A For JBU-100-A, JBU-100-A6, JBU-100-L-A**

- Install the light module in the terminal blocks (for JBU-100-L-A)
- Stow wires in box and install lid.
- Secure flexible tube with tape (nVent RAYCHEM GT-66 or GS-54).

* Off-pipe installation of JBU-100-A is shown. JBU-100 kits can be installed on the pipe using universal mounting bracket (UMB). Please refer to H54170.

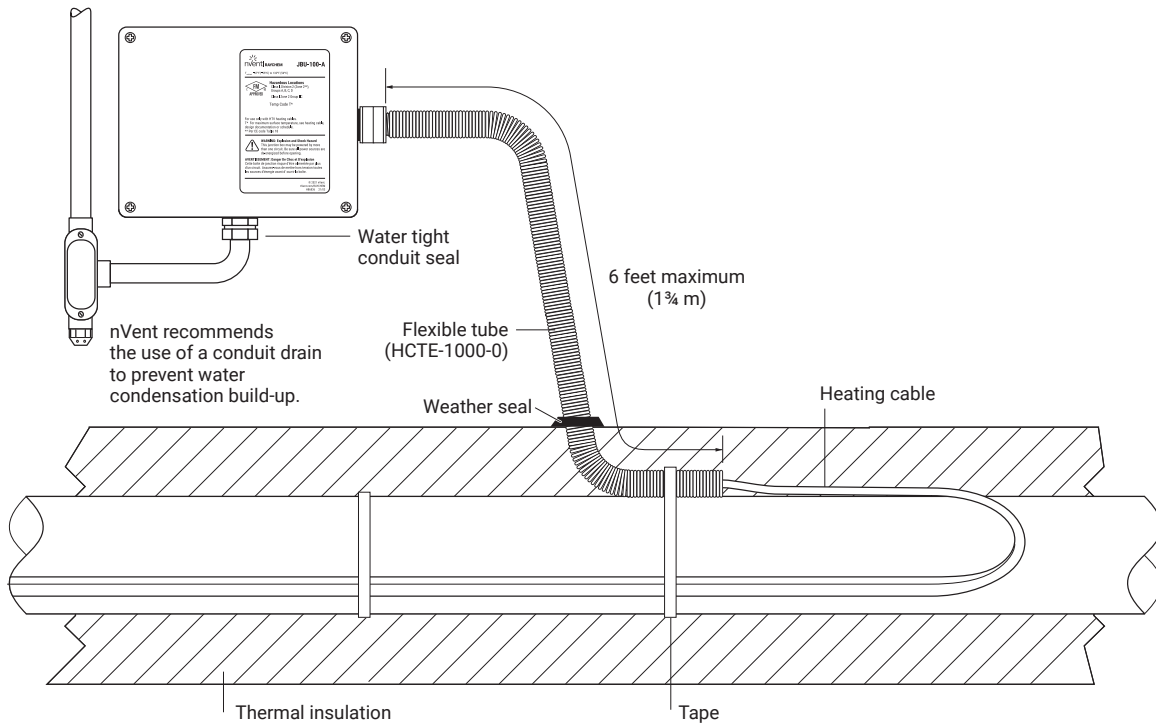

14B For GM-X, GM-XT and threaded junction boxes (outdoor location)

- Install the junction box either directly to the gland fitting in the cap of the Y fitting or to the end of the flexible conduit as shown below.
- Stow wires in box and install lid.

⚠ WARNING: Prevent mechanical damage. When installed as shown, the junction box is supported by a non-metallic mounting gland. This method may only be used where the box is not exposed to mechanical stress, static loads, or impact. Protect it with a shield or mount it out of the reach of people or moving equipment.

⚠ AVERTISSEMENT : prévention des dommages mécaniques. Lorsqu'il est installé comme sur l'image, le boîtier de raccordement est supporté par un presse-étoupe de montage non métallique. Cette méthode doit être utilisée seulement là où le boîtier n'est pas exposé à des contraintes mécaniques, des charges statique, ou impact. Protéger le boîtier avec un blindage ou installer le hors de portée des gens ou des équipements mobiles.

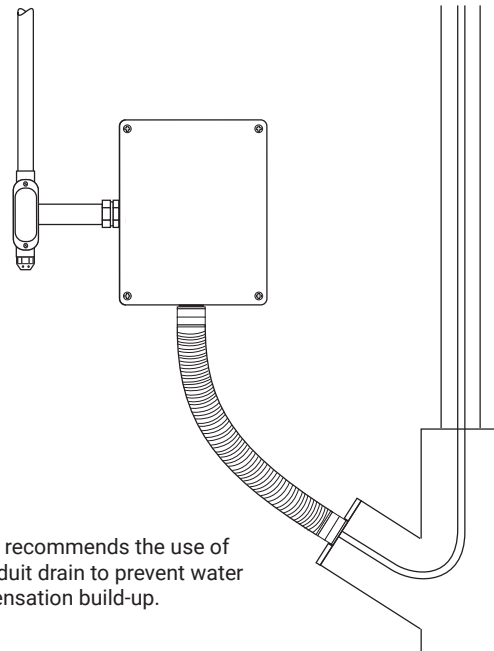
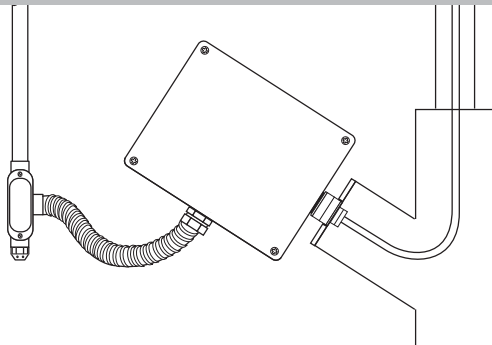

nVent recommends the use of a conduit drain to prevent water condensation build-up.

14C For GM-X, GM-XT and through hole junction boxes (indoor dry location)

- Install the junction box either directly to the gland fitting in the cap of the Y fitting or to the end of the flexible conduit as shown below.
- Stow wires in box and install lid.

⚠ WARNING: Prevent mechanical damage. When installed as shown, the junction box is supported by a non-metallic mounting gland. This method may only be used where the box is not exposed to mechanical stress, static loads, or impact. Protect it with a shield or mount it out of the reach of people or moving equipment.

⚠ AVERTISSEMENT : prévention des dommages mécaniques. Lorsqu'il est installé comme sur l'image, le boîtier de raccordement est supporté par un presse-étoupe de montage non métallique. Cette méthode doit être utilisée seulement là où le boîtier n'est pas exposé à des contraintes mécaniques, des charges statique, ou impact. Protéger le boîtier avec un blindage ou installer le hors de portée des gens ou des équipements mobiles.

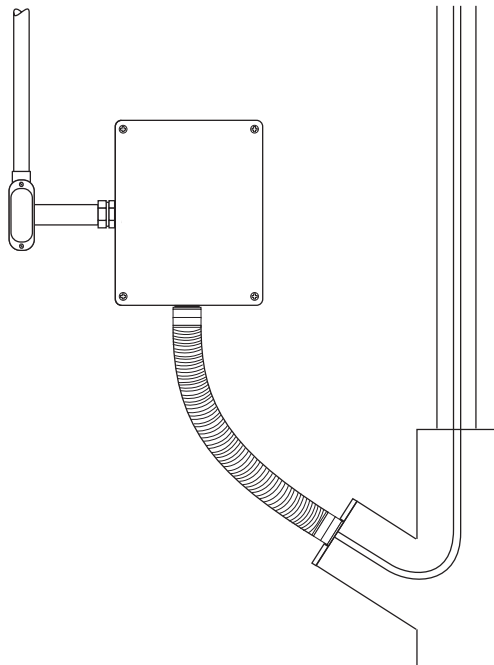
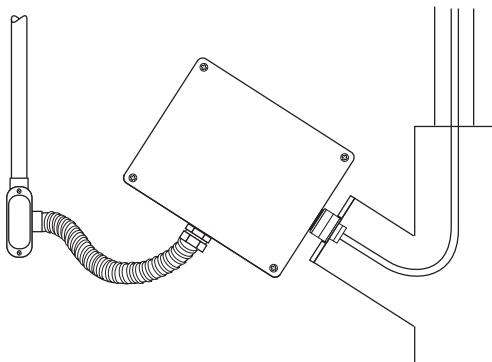

14D For installation in instrument enclosures

- Install the power junction box either directly to the instrument enclosure or to the end of the flexible conduit.
- Install C75-100-A and associated heat-tracing cable inside the instrument enclosure and close the lid.

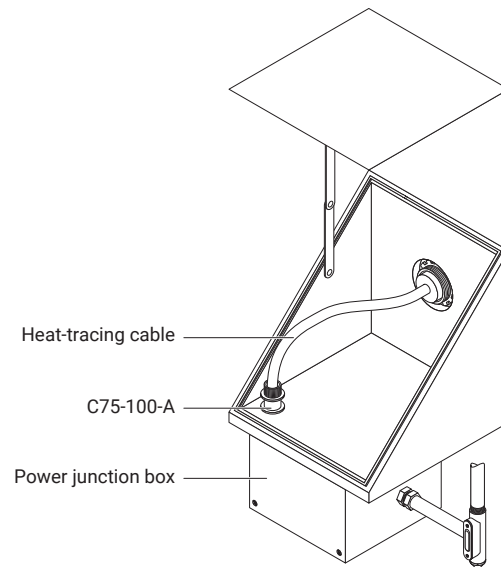

⚠ WARNING: EXPLOSION HAZARD- SUBSTITUTION OF COMPONENTS MAY IMPAIR SUITABILITY FOR CLASS I DIVISION 2 (Zone 2)

⚠ AVERTISSEMENT: RISQUE D'EXPLOSION. LA SUBSTITUTION DE COMPOSANTS PEUT RENDRE CE MATÉRIEL INACCEPTABLE POUR LES EMBLEMES DE CLASSE I, DIVISION 2.

⚠ WARNING: EXPLOSION HAZARD- DO NOT DISCONNECT EQUIPMENT UNLESS POWER HAS BEEN SWITCHED OFF OR THE AREA IS KNOWN TO BE NON-HAZARDOUS.

⚠ AVERTISSEMENT: RISQUE D'EXPLOSION. NE PAS DÉBRANCHER L'APPAREIL À MOINS D'AVOIR COUPÉ L'ALIMENTATION ÉLECTRIQUE OU À MOINS QU'IL NE S'AGISSE D'UN EMBLEMES NON DANGEREUX

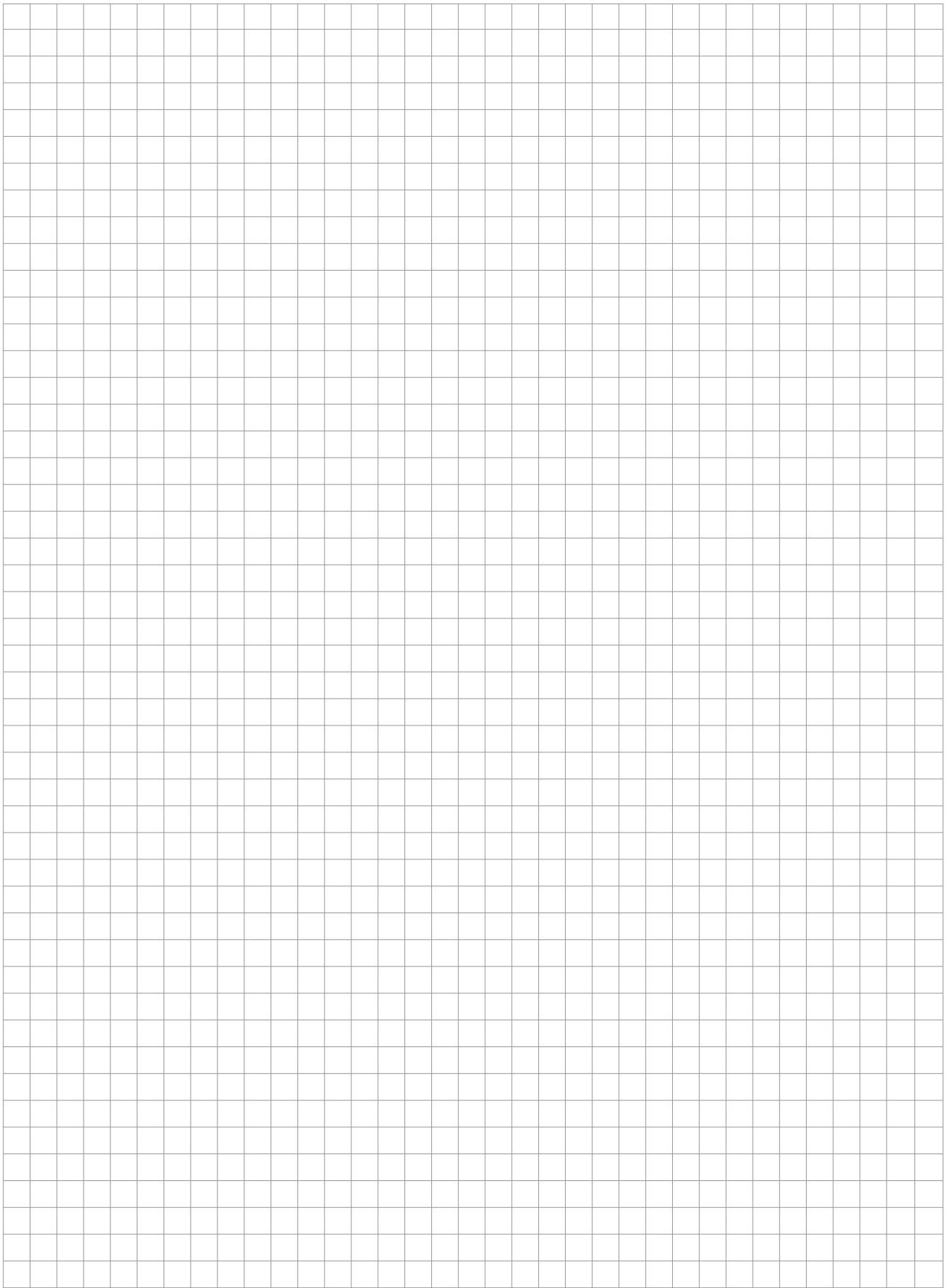

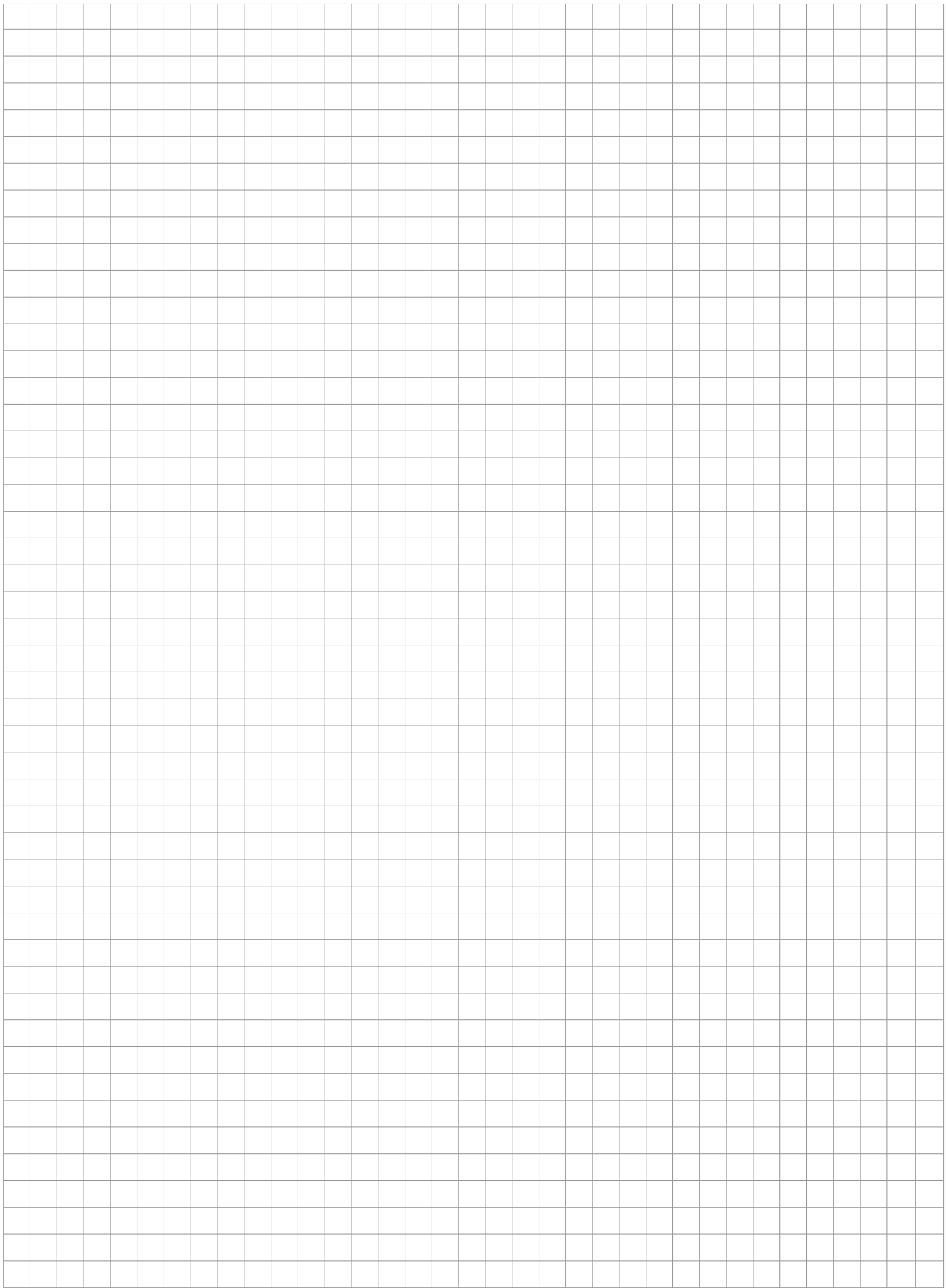

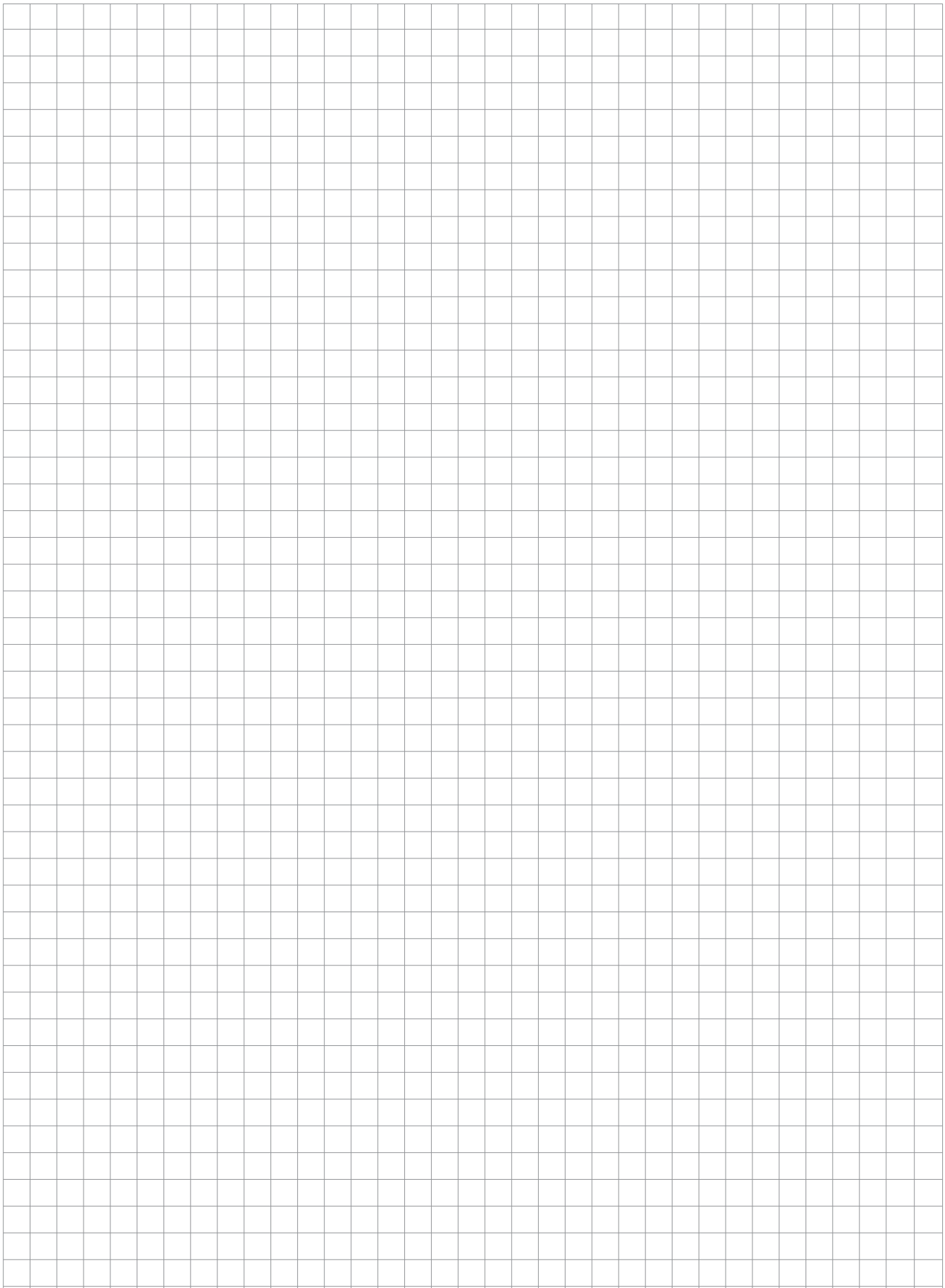

North America

Tel +1.800.545.6258
Fax +1.800.527.5703
thermal.info@nVent.com

Europe, Middle East, Africa

Tel +32.16.213.511
Fax +32.16.213.604
thermal.info@nVent.com

Asia Pacific

Tel +86.21.2412.1688
Fax +86.21.5426.3167
cn.thermal.info@nVent.com

Latin America

Tel +1.713.868.4800
Fax +1.713.868.2333
thermal.info@nVent.com



nVent.com/RAYCHEM