



ROOFTOP PYRAMID ST ADJUSTABLE STRUT SUPPORT, 16" X 7"-18"

CATALOG NUMBER

PSA16AH18



FEATURES

Height adjustability provides effective navigation of pipe, conduit, duct and cable tray around obstructions

Foam bottom offers low abrasion interface for better roof membrane protection

Compatible with roof surfaces including single ply, bituminous, metal and spray foam

Provides superior load distribution, even with varying rooftop surfaces

Ready to use out of the box, saving installation time and labor

Multiple sizes and load ratings offer the ability to tailor the solution to the application

Hot-dip galvanized and UV stabilized for long lasting performance

PRODUCT ATTRIBUTES

Material: Polyethylene;Polypropylene;Steel

Finish: Hot-Dip Galvanized

Temperature: -50 to 150 °F

Static Load Safety Factor: 3:1

Length 1 (L1): 16"

Length 2 (L2): 19"

Height (H): 7" - 18"

Width (W): 8"

Surface Area: 142in²

Unit Weight: 6 lb

Static Load (F): 1500lb

DIAGRAMS

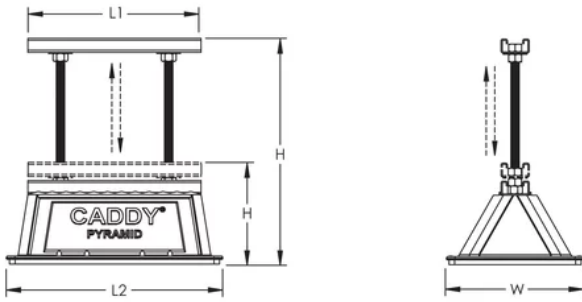

WARNING

nVent products shall be installed and used only as indicated in nVent's product instruction sheets and training materials. Instruction sheets are available at www.nvent.com and from your nVent customer service representative. Improper installation, misuse, misapplication or other failure to completely follow nVent's instructions and warnings may cause product malfunction, property damage, serious bodily injury and death and/or void your warranty.

North America

+1.800.753.9221
Option 1 – Customer Care
Option 2 – Technical Support

Europe

Netherlands:
+31 800-0200135
France:
+33 800 901 793

Europe

Germany:
800 1890272
Other Countries:
+31 13 5835404

APAC

Shanghai:
+ 86 21 2412 1618/19
Sydney:
+61 2 9751 8500



Our powerful portfolio of brands:
nVent.com CADDY ERICO HOFFMAN RAYCHEM SCHROFF
TRACER

© 2024 nVent. All nVent marks and logos are owned or licensed by nVent Services GmbH or its affiliates. All other trademarks are the property of their respective owners.

nVent reserves the right to change specifications without notice.